

MANUAL DE

Plomería

El libro azul

Graves



LIMUSA

Temas que trata la obra:

- Instrucciones
- Ángulos más comunes en las tuberías y maneras de resolverlos
- Ángulos conocidos y desconocidos, y tablas de los mismos
- Determinación de los desplazamientos con giro
- Cortes angulares en las tuberías
- Curvas hechas con varias piezas con cortes angulares
- Verdadero dimensionamiento de la "Y"
- Asiento a 90° en tuberías de peso estándar (Tes)
- La circunferencia de la tubería dividida en partes iguales
- Asiento a 90° en tuberías extralueres (Tes)
- Intersecciones excéntricas en tuberías a 90°
- Derivaciones a 45°
- Soportes concéntricos y excéntricos en codos a 90° de radio largo, 3 tipos
- Ángulos entre los agujeros paratomillos en las bridas
- Trazado de plantillas de tuberías
- Trazado de la plantilla para un casquete semiesférico tipo cáscara de naranja
- Trazado de un reductor concéntrico
- Trazado de la plantilla para un reductor excéntrico
- Trazado de los agujeros en las bridas
- Trazado de las líneas de ordenadas y sus longitudes para una tobera concéntrica o tangencial
- Trazado del serpenlín de un tanque
- Cortes angulares de los fierroángulos y ménsulas de los mismos
- Desplazamientos especiales
- Datos de bridas gemelas
- Centros de reductores excéntricos y bridas reductoras excéntricas
- Centros de codos soldables a tope de 15°, 22 1/2°, 30° y 60° cortados de codos de 90° de radio largo
- Datos de roscas de tubería
- Dimensiones de conexiones soldables de tubería
- Dimensiones en accesorios soldables de campana y roscados
- Dimensiones de válvulas bridadas de acero fundido
- Dimensiones de los accesorios bridados de acero fundido, etc.

MANUAL DE PLOMERÍA

EL LIBRO AZUL

MANUAL DE PLOMERÍA

EL LIBRO AZUL

W.V. Graves
Anteriormente Instructor de Plomería
Lee College, Bautown, Texas

LIMUSA



Graves, W. V.

Manual de plomería : El libro azul = The pipe fitters blue book / W. V. Graves. - México : Limusa, 2008.

180 p. : il. ; 15.5 x 10.5 cm.

ISBN-13: 978-968-18-1707-7

Rústica.

1. Plomería - Manuales

I. García Ferrer, Carlos Alberto, Jr.

Dewey: 696.1 | 22 / G7761m

LC: TH6125

VERSIÓN AUTORIZADA EN ESPAÑOL DE LA OBRA PUBLICADA EN INGLÉS
CON EL TÍTULO:

THE PIPE FITTERS BLUE BOOK

© W.V. GRAVES.

COLABORADOR EN LA TRADUCCIÓN:

CARLOS ALBERTO GARCÍA FERRER

INGENIERO QUÍMICO POR LA UNIVERSIDAD DE LA HABANA, CUBA.

REVISIÓN:

RUBÉN ÁVILA ESPINOZA

INGENIERO MECÁNICO ELECTRICISTA, CATEDRÁTICO TITULAR DE PROCESOS DE
MANUFACTURA EN LA FACULTAD DE INGENIERÍA DE LA UNIVERSIDAD NACIONAL
AUTÓNOMA DE MÉXICO.

LA PRESENTACIÓN Y DISPOSICIÓN EN CONJUNTO DE

MANUAL DE PLOMERÍA

EL LIBRO AZUL

SON PROPIEDAD DEL EDITOR. NINGUNA PARTE DE ESTA OBRA PUEDE SER
REPRODUCIDA O TRANSMITIDA, MEDIANTE NINGÚN SISTEMA O MÉTODO,
ELECTRÓNICO O MECÁNICO (INCLUYENDO EL FOTOCOPIADO, LA GRABACIÓN O
CUALQUIER SISTEMA DE RECUPERACIÓN Y ALMACENAMIENTO DE INFOR-
MACIÓN), SIN CONSENTIMIENTO POR ESCRITO DEL EDITOR.

DERECHOS RESERVADOS:

© 2008, EDITORIAL LIMUSA, S.A. DE C.V.

GRUPO NORIEGA EDITORES

BALDERAS 95, MÉXICO, D.F.

C.P. 06040

5130 0700

5512 2903

limusa@noriega.com.mx

www.noriega.com.mx

CANIEM Núm. 121

HECHO EN MÉXICO

ISBN-13: 978-968-18-1707-7

25.1



PROLOGO E INSTRUCCIONES

El autor ha incluido en este libro la información y tablas que más se necesitan en los trabajos de plomería.

Las explicaciones y los métodos usados se han simplificado tanto como ha sido posible, a fin de que no se tenga dificultad alguna para entenderlos.

Muchos de los cortes de fabricación que aparecen indicados en este libro se basan en el diámetro interior de la tubería vertical o del ramal que se ha de ajustar al diámetro exterior del cabezal, y se deben cortar radialmente, con la boquilla de corte del soplete apuntando siempre al centro de la tubería.

Después del corte, las tuberías se podrán colocar sobre el cabezal y así poder marcar la línea de corte del cabezal.

Los cortes angulares deben cortarse con la boquilla del soplete siguiendo la línea como si se tratara de un corte con segueta.

La tubería se puede marcar en cuartos, octavos o dieciseisavos, utilizando la tabla incluida en el libro o doblando una tira de papel que se ajusta alrededor de la tubería, de modo que los extremos de la tira apenas se toquen.

La tira envolvente se debe ajustar cuidadosamente a la tubería y mantener a escuadra para poder tener una línea de referencia exacta.

Nótese que las tablas de fabricación se han calculado para usarlas con tuberías de peso estándar y grosor extrafuerte, y sólo serán exactas para estos valores de grosor.

CONTENIDO

Instrucciones	2
Angulos más comunes en las tuberías y maneras de resolverlos	5-8
Angulos conocidos y desconocidos, y tablas de los mismos	9-10
Determinación de los desplazamientos con giro	11-12
Cortes angulares en las tuberías	13-19
Curvas hechas con varias piezas con cortes angulares	20-25
Verdadero dimensionamiento de la "Y"	26
Asiento a 90° en tuberías de peso estándar (Tes)	27-29
La circunferencia de la tubería dividida en partes iguales	30
Asiento a 90° en tuberías extrafuertes (Tes)	31-32
Intersecciones excéntricas en tuberías a 90°	33-36
Derivaciones a 45°	37-40
Soportes concéntricos y excéntricos en codos a 90° de radio largo, 3 tipos	41-51
Angulos entre los agujeros para tornillos en las bridas	52
Trazado de plantillas de tuberías	53-58
Trazado de la plantilla para un casquete semiesférico tipo cáscara de naranja	59-60
Trazado de un reductor concéntrico	61-64
Trazado de la plantilla para un reductor excéntrico	65-69
Trazado de los agujeros en las bridas	70
Trazado de las líneas de ordenados y sus longitudes para una tobera concéntrica o tangencial	71-72
Trazado del serpenitín de un tanque	73-74
Cortes angulares de los fierroángulos y ménsulas de los mismos	75-76
Desplazamientos especiales	77-82
Datos de bridas gemelas	83-84
Centros de reductores excéntricos y bridas reductoras excéntricas	85-86
Centros de codos soldables a tope de 15°, 22½°, 30° y 60° cortados de codos de 90° de radio largo	87



Datos de roscas de tubería	88
Dimensiones de conexiones soldables en tubería	89
Dimensiones en accesorios soldables de campana y roscados	90
Dimensiones de válvulas bridadas de acero fundido	91
Dimensiones de los accesorios bridados de acero fundido	92
Tamaños y grosores de pared de las tuberías comerciales	93-94
Dimensiones generales de accesorios soldables	95-100
Dimensiones generales de las bridas de acero forjado	101-108
Tablas de pernos, juntas y números de las juntas	109-115
Tamaño de las llaves de tuercas, de las brocas para machuelos y de los machuelos	116
Tablas para pernos en bridas del tipo de orificio	117-118
Diámetros interiores y exteriores de las tuberías, diámetros internos de las bridas	119
Tabla comparativa de materiales de juntas y empaques	120
Señales manuales para equipos manejados con grúa	121-122
Señales manuales para grúas viajeras y portal	123
Información útil. Expansión en tubos. Dobleces en tubos. El círculo: pulgadas y pies convertidos a milímetros	124
Constantes de conversión	125
Equivalentes decimales, fracciones y milímetros	126
Tablas de cargas seguras para cables de alambre y cuerdas de manila	127
Decimales de un pie	128
Minutos convertidos a decimales de grados, y fórmulas trigonométricas	129
Tablas trigonométricas	130-174
Peso de la tubería y del agua por pie lineal; conversión de carga de pies de agua a lb/pulg	175

ANGULOS MAS COMUNES EN LAS TUBERIAS Y MANERA DE RESOLVERLOS

NOTESE QUE LAS NUEVE FIGURAS SIGUIENTES INCLUYEN UN TRIANGULO RECTANGULO. Los plomeros llaman a las longitudes de los lados: *altura*, *proyección* y *recorrido*.

Estos términos se pueden utilizar para hallar los ángulos, así como la longitud de los lados, haciendo referencia a las páginas 9 y 10 de este libro.

FIGURA 1. Se muestra un desplazamiento de 30° . La parte horizontal (proyección) de la tubería corta al recorrido formando un ángulo de 30° . Si se conoce la longitud de la *altura*, se puede hallar la longitud de la *proyección* y del *recorrido*, refiriéndose a la página 10 bajo la cabeza de columna *ángulo conocido*, en la columna correspondiente a los 30° . Estas fórmulas se pueden usar para determinar cualquier ángulo que no aparezca en la tabla, empleando las tablas trigonométricas que aparecen en la parte posterior del libro.

FIGURA 2. Es el mismo triángulo anterior, pero la tubería está en posición vertical y corta con un ángulo de 60° . Para hallar la longitud de la *proyección* y del *recorrido*, refiérase a la página 10 bajo *ángulo conocido* en la columna de 60° . Nótese que cuando el lado de la *altura* es mayor que el lado de la *proyección*, el ángulo será siempre mayor de 45° .

FIGURA 3. Se muestra un recipiente con una tobera que forma un ángulo de 30° con la línea de referencia. Si se conoce la distancia desde la cara de la tobera a la línea de centro del recipiente, se añadirá la longitud de colocación de un codo soldable de 30° , además de una brida cuello soldable. Véase la figura 8, en la que se muestra el método para calcular la longitud de trazado de un codo soldable de 30° . La suma de estas dimensiones dará la longitud del lado del recorrido. Para hallar los valores de los lados de la *altura* y *proyección*, se hará referencia a la página 10 bajo la cabeza de columna *ángulo conocido*.

FIGURA 4. Se presentan dos desplazamientos a 60° , escalonados de tal modo que se mantengan iguales espaciamentos entre los ejes de las tuberías. Nótese que se muestran dos triángulos de 30° . **FORMULA PARA DESPLAZAMIENTOS ESCALONADOS = DISTANCIA CENTRO A CENTRO ENTRE LAS TUBERIAS \times TANGENTE DE LA MITAD DEL ANGULO DE GIRO DEL DESPLAZAMIENTO.** El valor para 60° es 0.577; para 45° , 0.414; para 30° , 0.268.

ANGULOS MAS COMUNES EN LAS TUBERIAS Y MANERA DE RESOLVERLOS

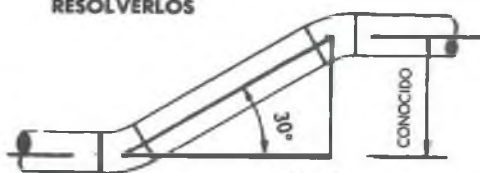

No. 1

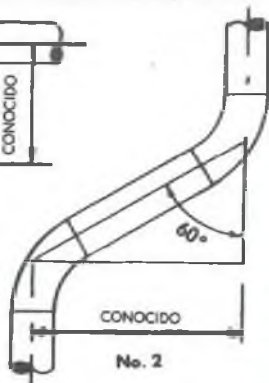

No. 2

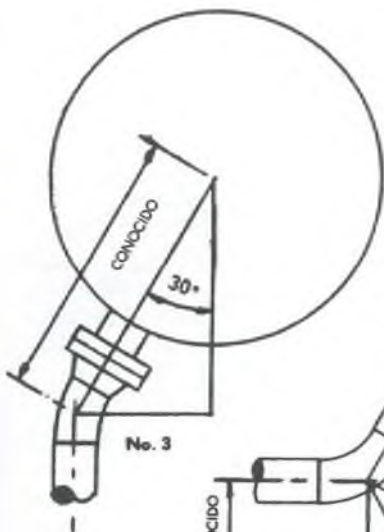

No. 3

DESPLAZAMIENTOS ESCALONADOS

$22\frac{1}{2}^\circ$	= Conocido \times 0.199
30°	= Conocido \times 0.268
45°	= Conocido \times 0.414
60°	= Conocido \times 0.577

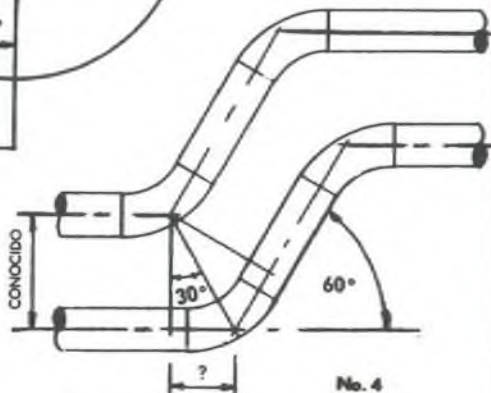

No. 4

FIGURA 5. Se muestra un triángulo rectángulo trazado para un corte angular sobre el tubo. El ángulo de corte es igual a la mitad del ángulo del quiebre. FORMULA PARA UN CORTE ANGULAR EN UN TUBO = D.E. DEL TUBO \times TANGENTE DEL ANGULO DE CORTE. Por lo general se traza una sola línea (envolvente) alrededor del tubo y se marca la mitad de la dimensión anterior a cada lado de la línea. Hágase referencia a las páginas 13 a 19, en las que se muestran ejemplos de trazado y tablas de dimensiones calculadas.

FIGURA 6. Se muestra una sola pieza de fierroángulo, cortado y doblado para formar un quiebre de una sola pieza. Se marca la línea de centro y se traza un corte a cada lado de dicha línea, como aparece en la figura 6. La muestra tiene un ángulo de 135° y requiere de dos cortes de $67\frac{1}{2}^\circ$. FORMULA PARA EL CORTE = ANCHO MENOS UN GROSOR \times TANGENTE DEL ANGULO DE CORTE. Para información adicional, refiérase a las ménsulas de fierroángulo y a las tablas de dimensiones calculadas.

FIGURA 7. Se trata de una pieza de fierroángulo que se corta a través del ancho total. Se requieren dos piezas para formar un quiebre. FORMULA PARA EL CORTE = ANCHO \times TANGENTE DEL ANGULO DE CORTE. Los cortes con otros tipos de perfiles de acero se pueden determinar por medio de las fórmulas o se pueden marcar con un transportador.

FIGURA 8. Se trata de un doblez de 60° en un tubo; se forman dos triángulos rectángulos para determinar la longitud de trazado o la distancia del extremo hasta el centro. Como se conoce por lo general el radio de los codos soldables y los dobleces, es posible calcular la dimensión del extremo al centro. FORMULA = RADIO \times TANGENTE DE LA MITAD DEL ANGULO DEL ACCESORIO Y/O DOBLEZ. Véase, en este libro, la tabla de las dimensiones calculadas de los codos soldables de radio largo.

FIGURA 9. Se presenta un codo soldable de 90° que se ha hecho girar 45° , al que se le ha añadido un codo de 45° para que la tubería quede en posición horizontal. La suma de las distancias entre los centros de estos accesorios forma el lado de recorrido de un triángulo rectángulo. Se pueden calcular los lados de altura y proyección, refiriéndose a la página 10, bajo ángulo conocido. Con este procedimiento se pueden elaborar todos los tipos de accesorios o combinaciones de los mismos que se hayan girado sobre un cierto ángulo.

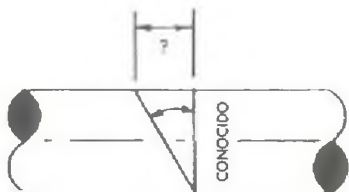

No. 5

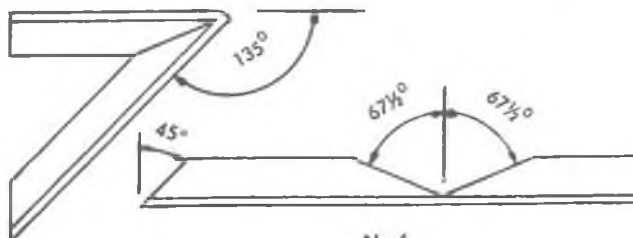

No. 6



No. 7

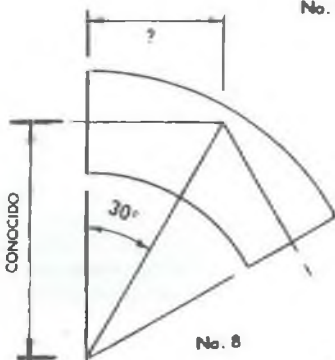

No. 8

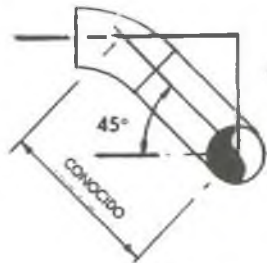

No. 9

DETERMINACION DE ANGULOS UTILIZANDO TERMINOS CONOCIDOS POR EL PLOMERO

Los ángulos en las tuberías y la longitud de sus lados se pueden hallar fácilmente utilizando los métodos siguientes. Se basan en la determinación de los ángulos y las longitudes de los lados de un triángulo rectángulo. Un triángulo tiene sus ángulos que suman 180° . Como uno de los ángulos es igual a 90° , la suma de los otros dos será siempre igual a 90° .

REGLA PARA HALLAR UN ANGULO NO CONOCIDO O LA LONGITUD DE UN LADO NO CONOCIDO

Para hallar un ángulo no conocido se debe conocer la longitud de dos lados, por ejemplo, la *altura* y la *proyección*. Para hallar la longitud de un lado no conocido, se debe conocer un ángulo y la longitud de un lado.

COMO USAR LAS TABLAS TRIGONOMETRICAS QUE APARECEN AL FINAL DEL LIBRO

Para ángulos de 45° o menores, se leen los ángulos, constantes y minutos de grado, desde la parte de arriba de la página hacia abajo. Para ángulos de 45° o mayores, se leen los ángulos, constantes y minutos de grado, desde la parte de abajo de la página hacia arriba.

COMO HALLAR UN ANGULO NO CONOCIDO

EJEMPLO: Refiérase al desplazamiento de la tubería de la página 6. Si la longitud de la *altura* es de 10 pulgadas y la *carrera* es de 20 pulgadas, ¿cuál será el ángulo de este desplazamiento? Se utiliza la tabla referente a **COMO HALLAR EL ANGULO**, y allí se ve que la *altura* dividida por el *recorrido* = seno de este ángulo. 10 dividido entre $20 = 0.500$, y buscando este valor en la columna **SENO** de las tablas trigonométricas, se ve que se trata de un ángulo de 30° . La tabla indica también que el *recorrido* dividido entre la *altura* = la *cosecante* de este ángulo.

COMO HALLAR LA LONGITUD DE UN LADO NO CONOCIDO

El desplazamiento considerado tiene un ángulo de 30° , la *altura* es de 10 pulgadas, y el *recorrido* es de 20 pulgadas. ¿Cuál será la longitud del lado de la *proyección*?

EJEMPLO: Al referirse a la tabla **ANGULOS CONOCIDOS**, se ve que la *proyección* = el *recorrido* \times el *coseno*, o sea, $20 \times 0.866 = 17.32$ ó $17\frac{5}{16}$ pulgadas. La tabla muestra también que la *proyección* = la *altura* \times la *cotangente*.

NOTA. Si la longitud de la *altura* es igual a la de la *proyección*, el ángulo es de 45° . Si la *altura* es menor que la *proyección*, el ángulo es menor de 45° .

SE DEBE INDICAR EN EL DIBUJO EL ANGULO ENTRE EL RECORRIDO Y LA PROYECCION. ALTURA = cateto opuesto; PROYECCION = cateto adyacente; RECORRIDO = hipotenusa.

COMO HALLAR EL ANGULO CUANDO SE CONOCE EL RECORRIDO DE DOS DE LOS LADOS



ALTIMA DIVIDIDA ENTRE RECORRIDO = SENO
 PROYECCION DIVIDIDA ENTRE RECORRIDO = COSENO
 ALTIMA DIVIDIDA ENTRE LA PROYECCION = TANGENTE
 PROYECCION DIVIDIDA ENTRE ALTIMA = COTANGENTE
 RECORRIDO DIVIDIDO ENTRE PROYECCION = SECANTE
 RECORRIDO DIVIDIDO ENTRE ALTIMA = COSECANTE

PARA HALLAR EL RECORRIDO DE LOS LADOS CUANDO SE CONOCE EL ANGULO	ANGULO DEL DESPLAZAMIENTO							
	60°	45°	30°	22½°	15°	11¼°	9°	7½°
ALTIMA = RECORRIDO X SENO	.866	.707	.500	.383	.259	.195	.156	.130
PROYECCION = RECORRIDO X COSENO	.500	.707	.866	.924	.966	.981	.988	.991
ALTIMA = PROYECCION X TANGENTE	1.732	1.000	.577	.414	.268	.199	.158	.132
PROYECCION = ALTIMA X COTANGENTE	.577	1.000	1.732	2.414	3.732	5.027	6.314	7.596
RECORRIDO = PROYECCION X SECANTE	2.000	1.414	1.155	1.082	1.035	1.020	1.012	1.008
RECORRIDO = ALTIMA X COSECANTE	1.155	1.414	2.000	2.613	3.864	5.126	6.392	7.661

DETERMINACION DE LOS DESPLAZAMIENTOS CON GIRO

Un desplazamiento con giro no es más que un desplazamiento sencillo que se ha hecho girar de manera que se mantenga en dos dimensiones, como se muestra en la figura a.

Para calcular un desplazamiento con giro es preciso hallar la distancia necesaria para que al doblar una tubería recta se mantengan esas dos dimensiones. Esto se muestra en la figura a como una tubería con dobleces a 90° . Una vez determinada esta distancia, se calcula el desplazamiento de la misma manera que si se tratara de uno simple. La manera más sencilla de hallar esta distancia es la de medir con una escuadra de acero entre las dimensiones de 10 pulg. y $21\frac{1}{4}$ pulg., como se muestra en la figura a. El valor obtenido de $23\frac{1}{2}$ pulg. es la verdadera dimensión de la altura y se vuelve a mostrar en verdadera dimensión en la figura b. Para hallar la dimensión del recorrido necesaria para cualquier otro ángulo, multiplíquese este valor de $23\frac{1}{2}$ pulg. de la altura \times la cosecante del ángulo que se utilice. En la figura b, se indica un ángulo de 45° . Para un ángulo de este valor, multiplíquese $23\frac{1}{2}$ pulg. \times 1.414 = $33\frac{1}{4}$ pulg. Para un ángulo de 30° , multiplíquese $23\frac{1}{2}$ pulg. \times 2.00 = 47 pulg.

También es posible calcular la distancia de $23\frac{1}{2}$ pulg. utilizando la raíz cuadrada; o, hallando el ángulo formado por la altura de 10 pulg. y la proyección de $21\frac{1}{4}$ pulg. Refiriéndose a la tabla PARA HALLAR EL ANGULO, al dividir $21\frac{1}{4}$ pulg. entre 10 pulg. se obtiene 2.125. Este valor representa la cotangente de $25^\circ 12'$. Una vez conocido el ángulo, se hace referencia a la tabla ANGULO CONOCIDO y se observa que el recorrido = altura \times cosecante, o sea 10 pulg. \times 2.3486 = $23\frac{1}{2}$. Este es el mismo valor obtenido con la escuadra de acero. Se puede utilizar este método cuando las distancias sean mayores que la longitud de la escuadra.

Se desea calcular un desplazamiento con giro que se mantenga también dentro de una dimensión dada como en (c) de la figura a, lo cual se puede efectuar fácilmente. Supóngase que la dimensión (c) sea de 18 pulg. Hágase referencia a la figura b, y obsérvese que $23\frac{1}{2}$ pulg. es la altura. El lado de 18 pulg. es la proyección. Se usan los valores de estos dos lados para calcular el ángulo. Se hace referencia a la tabla (PARA ENCONTRAR EL ANGULO). Se muestra que la ALTURA DIVIDIDA ENTRE LA PROYECCION = TANGENTE, o sea, $23\frac{1}{2}$ pulg. dividido entre 18 pulg. = 1.30555. Las tablas trigonométricas indican que se trata de la tangente de $52^\circ 33'$. Se tomará, para fines prácticos, $52^\circ 30'$ para calcular la longitud de la proyección y del recorrido. Véase la tabla ANGULO CONOCIDO. El lado de la proyección es igual a $23\frac{1}{2}$ pulg. \times 0.7673 = 18 pulg. El lado del recorrido es igual a $23\frac{1}{2}$ pulg. \times 1.2605 = $29\frac{6}{8}$ pulg. Cuando el lado de la altura es mayor que la proyección, el ángulo será mayor de 45° , y los ángulos en las tablas trigonométricas se leerán de abajo hacia arriba.

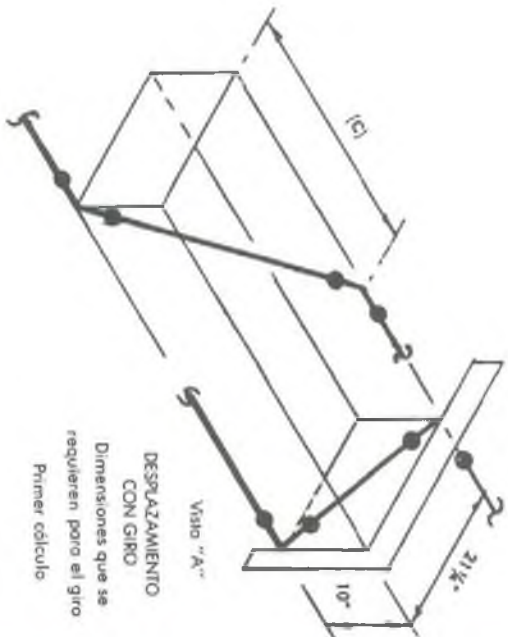
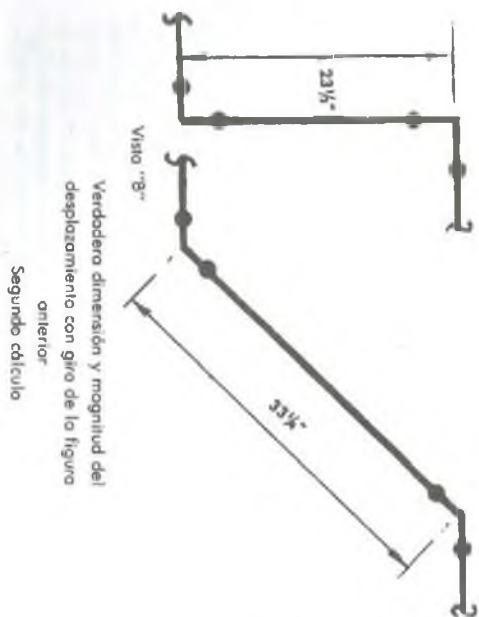

LOS ANGULOS DE CORTE SON IGUALES A LA MITAD DEL ANGULO DEL QUIEBRE QUE SE DESEA

LINEA DEL CORTE ANGULAR

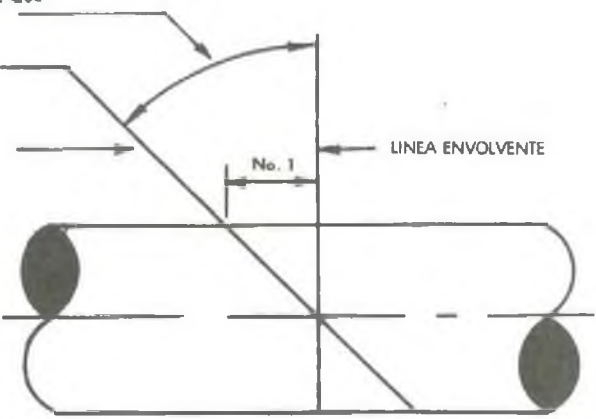
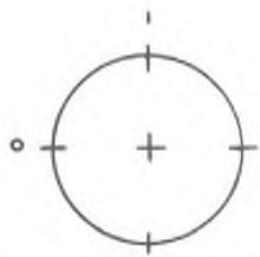

CORTES ANGULARES DE 1 1/2" A 3" CON EL TUBO MARCADO EN CUARTOS
 LA DIMENSION DE LA LINEA 1 ES IGUAL A LA TANGENTE DEL ANGULO DE CORTE X EL D.E. DEL TUBO DIVIDIDO ENTRE 2

CORTES ANGULARES DE 1½" HASTA 3", DEL TUBO DIVIDIDO EN CUARTOS

CORTE A 7½° PARA UN QUIEBRE DE 15°		CORTE A 22½° PARA UN QUIEBRE DE 45°	
TAMAÑO	NO. 1	TAMAÑO	NO. 1
1½	¼	1½	⅜
2	⅜	2	½
2½	¾	2½	¾
3	¾	3	¾
CORTE A 9° PARA UN QUIEBRE DE 18°		CORTE A 30° PARA UN QUIEBRE DE 60°	
TAMAÑO	NO. 1	TAMAÑO	NO. 1
1½	¼	1½	⅜
2	¾	2	½
2½	¾	2½	¾
3	¾	3	1
CORTE A 11¼° PARA UN QUIEBRE DE 22½°		CORTE A 45° PARA UN QUIEBRE DE 90°	
TAMAÑO	NO. 1	TAMAÑO	NO. 1
1½	¾	1½	½
2	¾	2	¾
2½	¾	2½	¾
3	¾	3	¾
CORTE A 15° PARA UN QUIEBRE DE 30°			
TAMAÑO	NO. 1		
1½	¼		
2	¾		
2½	¾		

LOS ANGULOS DE CORTE SON IGUALES
A LA MITAD DEL ANGULO DEL QUIEBRE
QUE SE DESEA

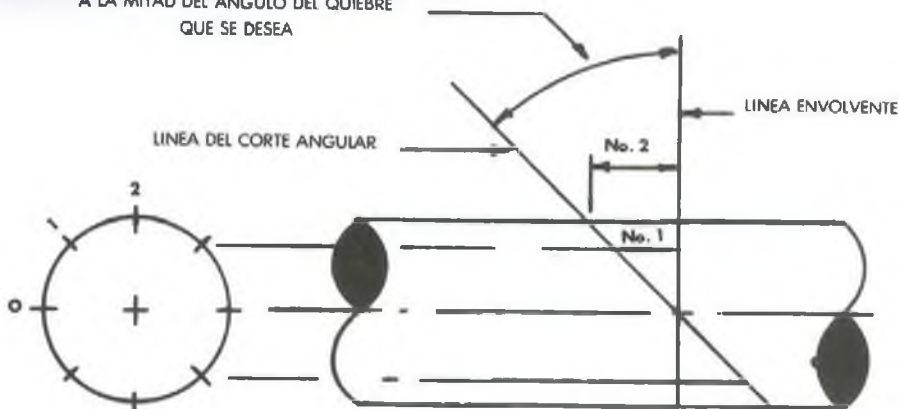

CORTES ANGULARES DE 4" A 10" CON EL TUBO MARCADO EN OCTAVOS
LA DIMENSION DE LA LINEA 2 ES IGUAL A LA TANGENTE DEL ANGULO DE CORTE X EL
D.E. DEL TUBO, DIVIDIDO ENTRE 2
LA DIMENSION DE LA LINEA 1 ES IGUAL A LA DIMENSION DE LA LINEA

$$2 \times 0.7071$$

CORTES ANGULARES DE 4" A 10" DEL TUBO DIVIDIDO EN OCTAVOS

CORTE A 7½° PARA UN QUIEBRE DE 15°			CORTE A 22½° PARA UN QUIEBRE DE 45°		
TAMAÑO	NO. 1	NO. 2	TAMAÑO	NO. 1	NO. 2
4	¾	¼	4	11/16	15/16
6	5/8	3/8	6	1	1 1/8
8	¾	9/16	8	1 ¼	1 ¾
10	1 ½	11/16	10	1 5/8	2 1/16
CORTE A 9° PARA UN QUIEBRE DE 18°			CORTE A 30° PARA UN QUIEBRE DE 60°		
TAMAÑO	NO. 1	NO. 2	TAMAÑO	NO. 1	NO. 2
4	¾	3/8	4	15/16	1 1/16
6	5/8	1/2	6	1 3/8	1 7/8
8	1 ½	11/16	8	1 ¾	2 ½
10	5/8	7/8	10	2 1/8	3 1/16
CORTE A 11¼° PARA UN QUIEBRE DE 22½°			CORTE A 45° PARA UN QUIEBRE DE 90°		
TAMAÑO	NO. 1	NO. 2	TAMAÑO	NO. 1	NO. 2
4	5/16	7/16	4	1 1/16	2 ¼
6	7/16	5/8	6	2 1/8	3 3/16
8	5/8	3/4	8	3 1/4	4 3/16
10	¾	1 1/16	10	3 11/16	5 1/8
CORTE A 15° PARA UN QUIEBRE DE 30°					
TAMAÑO	NO. 1	NO. 2			
4	5/8	9/16			
6	5/8	7/8			
8	1 1/16	1 1/8			
10	1	1 1/4			

LOS ANGULOS DE CORTE SON IGUALES A LA MITAD DEL ANGULO DEL QUIEBRE QUE SE DESEA

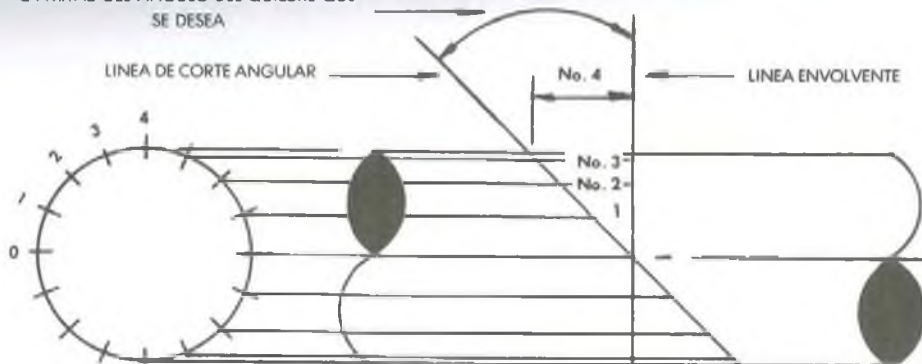

CORTES ANGULARES DE 12" A 24" CON EL TUBO MARCADO EN DIECISEISAVOS

LA DIMENSION DE LA LINEA 4 ES IGUAL A LA TANGENTE DEL ANGULO DE CORTE X EL D.E. DEL TUBO, DIVIDIDO ENTRE 2

- LA DIMENSION DE LA LINEA 3 ES IGUAL A LA DIMENSION DE LA LINEA 4 X 0.9239
- LA DIMENSION DE LA LINEA 2 ES IGUAL A LA DIMENSION DE LA LINEA 4 X 0.7071
- LA DIMENSION DE LA LINEA 1 ES IGUAL A LA DIMENSION DE LA LINEA 4 X 0.3827

**CORTES ANGULARES DE 12" A 24"
MARCAS DEL TUBO EN DIECISEISAVOS**

CORTE A 7½° PARA UN QUIEBRE DE 15°				
TAMAÑO	NO. 1	NO. 2	NO. 3	NO. 4
12	5/16	9/16	3/4	13/16
14	3/8	3/8	7/8	15/16
16	7/16	3/8	1	1 1/16
18	7/16	13/16	1 1/16	1 3/16
20	1/2	15/16	1 3/16	1 5/16
24	5/8	1 1/8	1 7/16	1 9/16
CORTE A 9° PARA UN QUIEBRE DE 18°				
TAMAÑO	NO. 1	NO. 2	NO. 3	NO. 4
12	3/8	11/16	1 1/16	1
14	7/16	13/16	1	1 3/8
16	1/2	3/8	1 3/16	1 1/4
18	9/16	1	1 5/16	1 7/16
20	5/8	1 1/8	1 7/16	1 9/16
24	3/4	1 5/16	1 3/4	1 7/8
CORTE A 11¼° PARA UN QUIEBRE DE 22½°				
TAMAÑO	NO. 1	NO. 2	NO. 3	NO. 4
12	3/2	7/8	1 3/16	1 1/4
14	1/2	1	1 5/16	1 3/8
16	5/8	1 1/8	1 7/16	1 5/16
18	11/16	1 1/4	1 11/16	1 13/16
20	3/4	1 3/8	1 13/16	2
24	15/16	1 11/16	2 3/16	2 1/2

**CORTES ANGULARES DE 12" A 24"
MARCAS DEL TUBO EN DIECISEISAVOS**

CORTE A 15° PARA UN QUIEBRE DE 30°				
TAMAÑO	NO. 1	NO. 2	NO. 3	NO. 4
12	5/8	1 1/16	1 3/16	1 11/16
14	3/4	1 5/16	1 3/4	1 7/8
16	13/16	1 1/2	2	2 3/8
18	15/16	1 11/16	2 1/4	2 5/8
20	1	1 7/8	2 1/2	2 11/16
24	1 3/4	2 3/4	3	3 5/8
CORTE A 22½° PARA UN QUIEBRE DE 45°				
TAMAÑO	NO. 1	NO. 2	NO. 3	NO. 4
12	1	1 1/8	2 7/16	2 5/8
14	1 1/8	2 1/16	2 11/16	2 7/8
16	1 3/4	2 5/8	3 1/16	3 3/16
18	1 7/16	2 5/8	3 7/16	3 3/4
20	1 9/16	2 13/16	3 13/16	4 1/8
24	1 7/8	3 1/2	4 5/8	5
CORTE A 30° PARA UN QUIEBRE DE 60°				
TAMAÑO	NO. 1	NO. 2	NO. 3	NO. 4
12	1 3/8	2 5/8	3 3/8	3 11/16
14	1 9/16	2 7/8	3 3/4	4 1/16
16	1 3/4	3 3/4	4 1/4	4 5/8
18	2	3 11/16	4 13/16	5 3/16
20	2 3/16	4 1/16	5 5/16	5 3/4
24	2 5/8	4 7/8	6 3/8	6 15/16

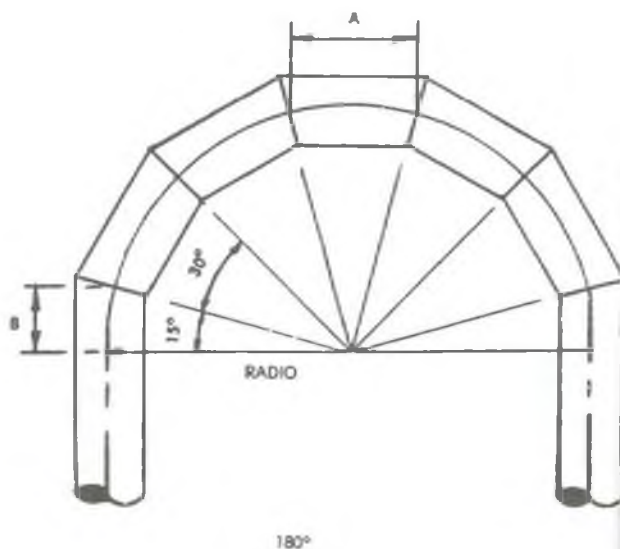

FORMULAS PARA CURVAS FORMADAS POR PIEZAS MULTIPLES PARA OBTENER EL RADIO Y EL NUMERO DE GRADOS DESEADO

1. EL ANGULO DE CORTE ES IGUAL A:
 Angulo de curva dividido entre el número de soldaduras multiplicado por 2
2. LONGITUD DE LA DIMENSION "B"
 Es igual al radio multiplicado por la tangente del ángulo de corte
3. LONGITUD DE LAS PIEZAS "A"
 Es igual a la dimensión "B" multiplicada por 2

CURVA A 90°, DE TRES PIEZAS
 DOS QUIEBRES A 45° CON CORTES A 22 1/2°

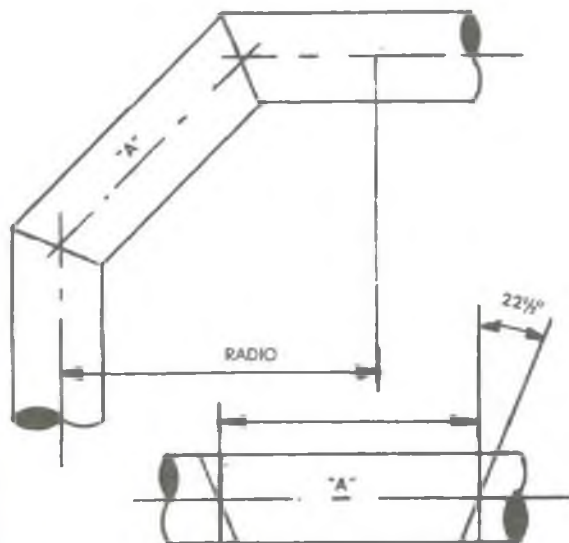

LA LONGITUD "A" ES IGUAL AL RADIO X 0.919 X 2

RADIO (Pulgadas)	LONGITUD "A" (Pulgadas)
12 "	9 ¹³ / ₁₆ "
18	14 ³ / ₈
24	19 ⁵ / ₈
30	24 ⁹ / ₁₆
36	29 ⁷ / ₁₆
42	34 ³ / ₈
48	39 ³ / ₈

CURVA A 90°, DE CUATRO PIEZAS
TRES QUIEBRES A 30° CON CORTES A 15°

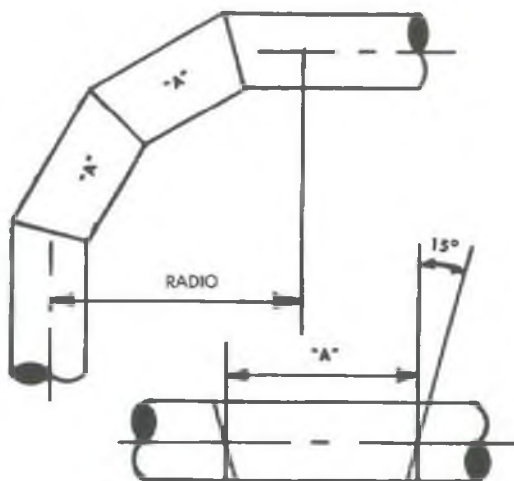

LA LONGITUD "A" ES IGUAL AL RADIO $\times 0.2679 \times 2$

RADIO (Pulgadas)	LONGITUD "A" (Pulgadas)
24 "	12 $\frac{7}{8}$ "
30	16 $\frac{1}{16}$
36	19 $\frac{3}{16}$
42	22 $\frac{1}{2}$
48	25 $\frac{3}{8}$
60	32 $\frac{1}{8}$
72	38 $\frac{9}{16}$
84	45
96	51 $\frac{7}{16}$

CURVA A 90°, DE CINCO PIEZAS
 CUATRO QUIEBRES A 22½° CON CORTES A 11¼°

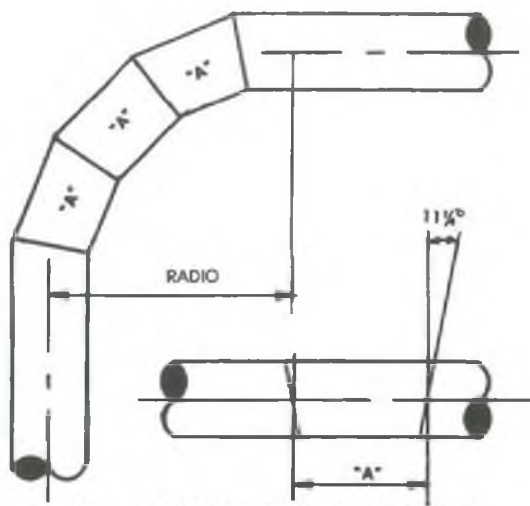

LA LONGITUD "A" ES IGUAL AL RADIO $\times 0.1989 \times 2$

RADIO (Pulgadas)	LONGITUD "A" (Pulgadas)
36 "	14 ⁵ / ₁₆ "
42	16 ¹¹ / ₁₆
48	19 ¹ / ₈
60	23 ⁷ / ₈
72	28 ⁵ / ₈
84	33 ⁷ / ₁₆
96	38 ³ / ₁₆
108	43
120	47 ³ / ₄
132	52 ¹ / ₂
144	57 ¹ / ₄

CURVA A 90°, CON SEIS PIEZAS
CINCO QUIEBRES A 18° CON CORTES A 9°

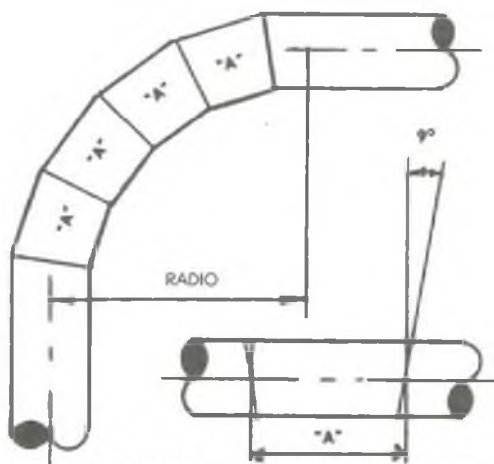

LA LONGITUD "A" ES IGUAL AL RADIO $\times 0.1584 \times 2$

RADIO (Pies)	LONGITUD "A" (Pulgadas)
4'	15 $\frac{1}{8}$ "
5	19
6	22 $\frac{11}{16}$
7	26 $\frac{5}{8}$
8	30 $\frac{3}{8}$
9	34 $\frac{3}{16}$
10	38
11	41 $\frac{11}{16}$
12	45 $\frac{5}{8}$
13	49 $\frac{3}{8}$
14	53 $\frac{3}{16}$
15	57

CURVA A 90°, CON SIETE PIEZAS
SEIS QUIEBRES A 15° CON CORTES A 7½

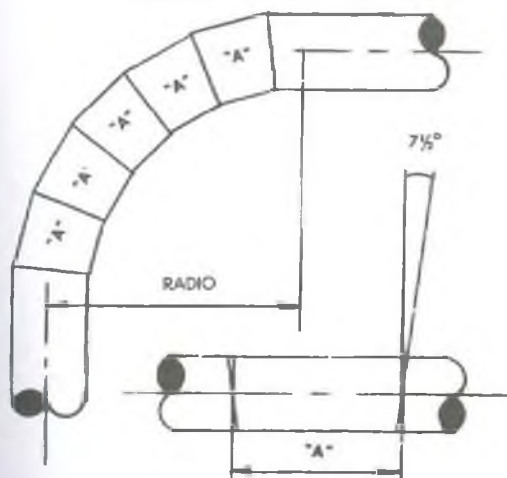

LA LONGITUD "A" ES IGUAL AL RADIO X 0.1316 X 2

RADIO (Pies)	LONGITUD "A" (Pulgadas)
5'	15 ¹¹ / ₁₆ "
6	18 ¹⁵ / ₁₆
7	22 ¹ / ₈
8	25 ¹ / ₄
9	28 ⁷ / ₁₆
10	31 ⁹ / ₁₆
11	34 ³ / ₄
12	37 ¹⁵ / ₁₆
13	41 ¹ / ₈
14	44 ¹ / ₄
15	47 ¹ / ₈
20	63 ¹ / ₈

VERDADERO DIMENSIONAMIENTO DE LA Y

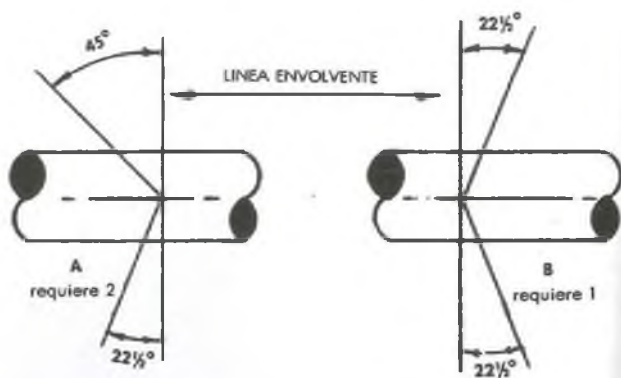
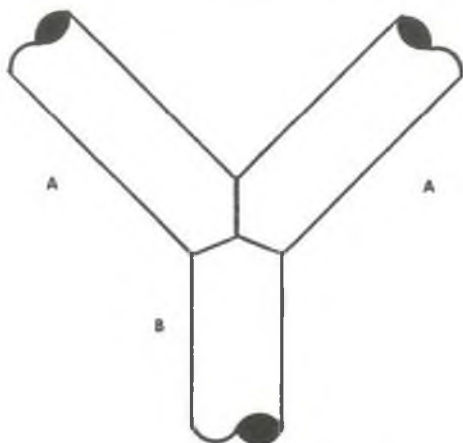

Consúltese el trazado de cortes angulares incluidas en este libro, para determinar el tamaño de los tubos.

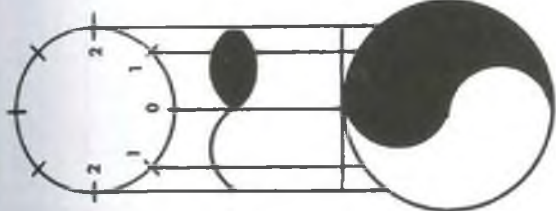

OCTAVOS

LINEA ENVOLVENTE

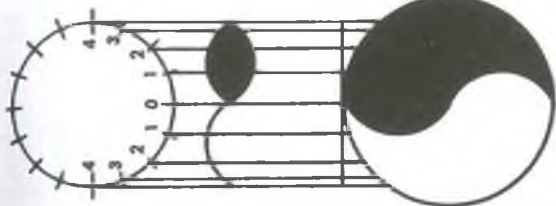

DIECISEISAVOS

DIVISIONES DE LA CIRCUNFERENCIA DEL TUBO

TAMAÑO DEL TUBO	DIAMETRO EXTERIOR	CIR.	1/2 CIR.	1/4 CIR.	1/8 CIR.	1/16 CIR.
1 1/2	1.9	5 ³¹ / ₃₂	3	1 1/2	3/4	3/8
2	2.375	7 ¹⁵ / ₃₂	3 3/4	1 7/8	15/16	15/32
2 1/2	2.875	9 ¹ / ₃₂	4 1/2	2 1/4	1 1/8	9/16
3	3.5	11	5 1/2	2 3/4	1 3/8	11/16
3 1/2	4	12 ⁹ / ₁₆	6 ⁹ / ₃₂	3 1/8	1 9/16	25/32
4	4.5	14 ¹ / ₈	7 1/16	3 17/32	1 3/4	7/8
5	5.563	17 ¹ / ₂	8 3/4	4 3/8	2 3/16	13/32
6	6.625	20 ¹³ / ₁₆	10 ¹³ / ₃₂	5 3/16	2 5/8	15/16
8	8.625	27 ⁹ / ₃₂	13 ⁹ / ₁₆	6 ²⁵ / ₃₂	3 3/8	1 11/16
10	10.75	33 ³ / ₄	16 ⁷ / ₈	8 ⁷ / ₁₆	4 ⁷ / ₃₂	2 1/8
12	12.75	40 ¹ / ₁₆	20 ¹ / ₃₂	10	5	2 1/2
14	14	44	22	11	5 1/2	2 3/4
16	16	50 ¹ / ₄	25 1/8	12 ⁹ / ₁₆	6 ⁹ / ₃₂	3 1/8
18	18	56 ⁹ / ₁₆	28 ⁹ / ₃₂	14 1/8	7 1/16	3 17/32
20	20	62 ¹³ / ₁₆	31 ¹³ / ₃₂	15 1/16	7 7/8	3 15/16
22	22	69 ¹ / ₈	34 ⁹ / ₁₆	17 ⁹ / ₃₂	8 5/8	4 5/16
24	24	75 ¹³ / ₃₂	37 1/16	18 ²⁷ / ₃₂	9 7/16	4 23/32
26	26	81 ¹¹ / ₁₆	40 ²⁷ / ₃₂	20 7/16	10 ⁷ / ₃₂	5 3/32
28	28	87 ³¹ / ₃₂	44	22	11	5 1/2
30	30	94 ¹ / ₄	47 1/8	23 ⁹ / ₁₆	11 ²⁵ / ₃₂	5 7/8
32	32	100 ¹⁷ / ₃₂	50 1/4	25 1/8	12 ⁹ / ₁₆	6 ⁹ / ₃₂
34	34	106 ¹³ / ₁₆	53 ¹³ / ₃₂	26 1/16	13 ¹¹ / ₃₂	6 11/16
36	36	113 ³ / ₃₂	56 ⁹ / ₁₆	28 ⁹ / ₃₂	14 1/8	7 1/16
42	42	131 ¹⁵ / ₁₆	65 ³¹ / ₃₂	33	16 1/2	8 1/4
48	48	150 ¹³ / ₁₆	75 ¹³ / ₃₂	37 1/16	18 ²⁷ / ₃₂	9 7/16

ALIENTO A 90° EN TUBERIAS

**VERTICALES EXTRA FUERTES
MARCAR EL TUBO EN OCTAVOS
TAMAÑO DEL CABEZAL**

	NO	24"	22"	20"	18"	16"	14"	12"	10"	8"	6"	4"	3"	
Tub. ver. de de 3"	1	1/16	1/16	1/16	1/16	1/16	1/16	1/16	1/8	1/8	3/16	1/4	3/16	
	2	1/16	1/8	1/8	1/8	1/8	1/8	1/8	1/4	1/4	1/2	1 1/16		
Tub. ver. de de 4"	1	1/16	1/16	1/16	1/16	1/16	1/16	1/16	1/8	1/8	1 1/16			
	2	1/8	1/8	1/8	1/8	1/8	1/8	1/8	1/4	1/4	1 1/8			
Tub. ver. de de 6"	1	1/16	1/16	1/16	1/16	1/16	1/16	1/16	1/8	1/8	1 1/16			
	2	1/8	1/8	1/8	1/8	1/8	1/8	1/8	1/4	1/4	1 1/8			
Tub. ver. de de 8"	1	1/16	1/16	1/16	1/16	1/16	1/16	1/16	1/8	1/8	1 1/16			
	2	1/8	1/8	1/8	1/8	1/8	1/8	1/8	1/4	1/4	1 1/8			
Tub. ver. de de 10"	1	1/16	1/16	1/16	1/16	1/16	1/16	1/16	1/8	1/8	1 1/16			
	2	1/8	1/8	1/8	1/8	1/8	1/8	1/8	1/4	1/4	1 1/8			

**ASIENTO A 90° EN TUBERIAS
VERTICALES EXTRAFUERTES
MARCAR EN DIECISEISAVOS
TAMAÑO DEL CABEZAL**

	12"	14"	16"	18"	20"	22"	24"	N
Tub. ver. de 12"	$\frac{7}{16}$	$\frac{3}{8}$	$\frac{5}{16}$	$\frac{5}{16}$	$\frac{3}{8}$	$\frac{3}{8}$	$\frac{3}{8}$	1
	$1\frac{1}{16}$	$1\frac{1}{8}$	$1\frac{1}{16}$	1	$\frac{7}{8}$	$1\frac{1}{16}$	$\frac{3}{8}$	2
	$3\frac{1}{8}$	$2\frac{1}{4}$	$2\frac{1}{8}$	$1\frac{13}{16}$	$1\frac{1}{2}$	$1\frac{7}{16}$	$1\frac{5}{8}$	3
	$3\frac{3}{8}$	$3\frac{1}{16}$	$2\frac{3}{8}$	$2\frac{3}{8}$	$1\frac{15}{16}$	$1\frac{11}{16}$	$1\frac{9}{16}$	4
Tub. ver. de 14"		$\frac{7}{16}$	$\frac{3}{8}$	$\frac{3}{8}$	$\frac{5}{16}$	$\frac{5}{16}$	$\frac{3}{8}$	1
		$1\frac{1}{8}$	$1\frac{1}{16}$	$1\frac{1}{8}$	$1\frac{1}{8}$	1	$1\frac{13}{16}$	2
		$3\frac{3}{8}$	$2\frac{11}{16}$	$2\frac{5}{8}$	2	$1\frac{13}{16}$	$1\frac{5}{8}$	3
		$4\frac{3}{8}$	$3\frac{1}{16}$	$2\frac{3}{8}$	$2\frac{1}{8}$	$2\frac{1}{8}$	$1\frac{13}{16}$	4
Tub. ver. de 16"			$\frac{9}{16}$	$\frac{1}{2}$	$\frac{7}{16}$	$\frac{3}{8}$	$\frac{3}{8}$	1
		2	$1\frac{1}{8}$	$1\frac{1}{2}$	$1\frac{1}{8}$	$1\frac{1}{8}$		2
		4	$3\frac{1}{8}$	$2\frac{13}{16}$	$2\frac{1}{8}$	$2\frac{3}{8}$		3
		$5\frac{1}{16}$	4	$3\frac{3}{8}$	$2\frac{15}{16}$	$2\frac{5}{8}$		4
Tub. ver. de 18"				$\frac{3}{8}$	$\frac{9}{16}$	$\frac{1}{2}$	$\frac{7}{16}$	1
				$2\frac{3}{16}$	2	$1\frac{13}{16}$	$1\frac{5}{8}$	2
			$4\frac{5}{8}$	$3\frac{13}{16}$	$3\frac{1}{8}$	$2\frac{13}{16}$		3
			$6\frac{1}{16}$	$4\frac{1}{4}$	4	$3\frac{1}{2}$		4
Tub. ver. de 20"					$1\frac{11}{16}$	$\frac{5}{8}$	$\frac{9}{16}$	1
					$2\frac{1}{4}$	$2\frac{5}{16}$	$2\frac{1}{4}$	2
					$5\frac{1}{16}$	$4\frac{3}{8}$	$3\frac{13}{16}$	3
					$6\frac{7}{8}$	$5\frac{1}{8}$	$4\frac{13}{16}$	4
Tub. ver. de 22"						$\frac{3}{4}$	$1\frac{1}{16}$	1
						$2\frac{7}{8}$	$2\frac{9}{16}$	2
						$5\frac{13}{16}$	$4\frac{15}{16}$	3
						$7\frac{3}{4}$	$6\frac{1}{16}$	4
Tub. ver. de 24"							$1\frac{13}{16}$	1
							$3\frac{1}{16}$	2
							$6\frac{7}{16}$	3
							$8\frac{1}{16}$	4

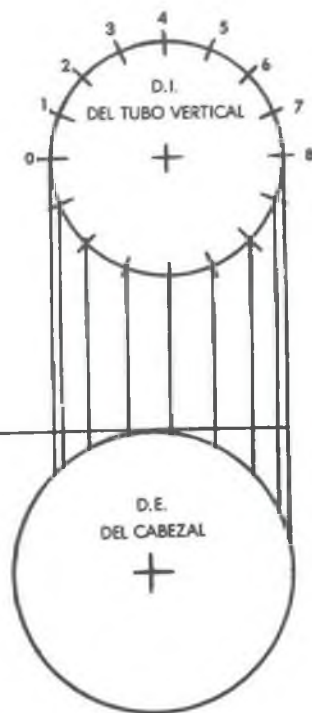

TUBERIAS VERTICALES EXCENRICAS, MARCAR EN DIECISEISAVOS

NOTA: Se dan estas longitudes para el ajuste de los diámetros interiores después de realizados los cortes.

TUBERIAS VERTICALES EXCENTRICAS A 90°
TUBERIAS VERTICALES DE PESO ESTANDAR
MARCAR DIECISEISAVOS
TAMAÑO DEL CABEZAL

	18"	20"	22"	24"	No
Tub. ver. de 16"	$2\frac{13}{16}$	$1\frac{3}{4}$	1	$\frac{9}{16}$	0
	$2\frac{5}{16}$	$1\frac{1}{4}$	$\frac{3}{4}$	$\frac{3}{8}$	1
	$1\frac{3}{8}$	$\frac{9}{16}$	$\frac{1}{4}$	$\frac{1}{16}$	2
	$\frac{3}{8}$	$\frac{1}{16}$	0	$\frac{3}{16}$	3
	$\frac{3}{8}$	$\frac{3}{16}$	$\frac{7}{16}$	$2\frac{11}{16}$	4
	$\frac{1}{2}$	$1\frac{1}{16}$	$1\frac{3}{8}$	$2\frac{3}{16}$	5
	$2\frac{11}{16}$	$3\frac{3}{4}$	$3\frac{3}{8}$	$4\frac{1}{2}$	6
	$4\frac{15}{16}$	$5\frac{3}{4}$	$6\frac{1}{2}$	$7\frac{5}{16}$	7
$6\frac{7}{16}$	$7\frac{5}{16}$	$8\frac{3}{8}$	9	8	
Tub. ver. de 18"		$3\frac{1}{2}$	$2\frac{1}{4}$	$1\frac{1}{8}$	0
		$2\frac{13}{16}$	$1\frac{3}{8}$	$1\frac{5}{16}$	1
		$1\frac{3}{4}$	$1\frac{3}{16}$	$\frac{1}{16}$	2
		$\frac{3}{8}$	$\frac{1}{16}$	0	3
		$\frac{1}{16}$	$\frac{3}{16}$	$\frac{3}{8}$	4
		1	$1\frac{1}{2}$	$1\frac{13}{16}$	5
		$2\frac{15}{16}$	$3\frac{9}{16}$	$4\frac{3}{16}$	6
		$5\frac{9}{16}$	$6\frac{3}{8}$	$7\frac{3}{8}$	7
	$7\frac{5}{16}$	$8\frac{1}{8}$	9	8	
Tub. ver. de 20"			$4\frac{3}{16}$	$2\frac{3}{8}$	0
			$3\frac{3}{16}$	$2\frac{1}{16}$	1
			$1\frac{11}{16}$	1	2
			$\frac{5}{16}$	$\frac{3}{8}$	3
			$\frac{1}{16}$	$\frac{3}{16}$	4
			$1\frac{1}{16}$	$1\frac{1}{16}$	5
			$3\frac{3}{8}$	$3\frac{3}{8}$	6
			$6\frac{3}{16}$	$6\frac{15}{16}$	7
		$8\frac{1}{2}$	9	8	
Tub. ver. de 22"				$4\frac{13}{16}$	0
				$3\frac{7}{8}$	1
				$1\frac{15}{16}$	2
				$\frac{3}{8}$	3
				$\frac{1}{16}$	4
				$1\frac{3}{8}$	5
				$3\frac{9}{16}$	6
				$6\frac{11}{16}$	7
			9	8	

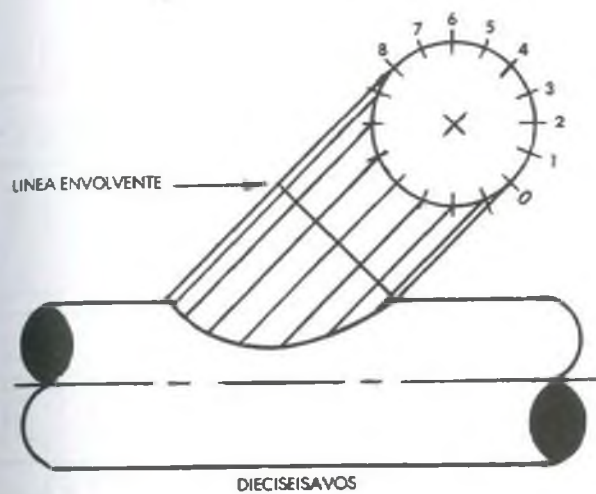
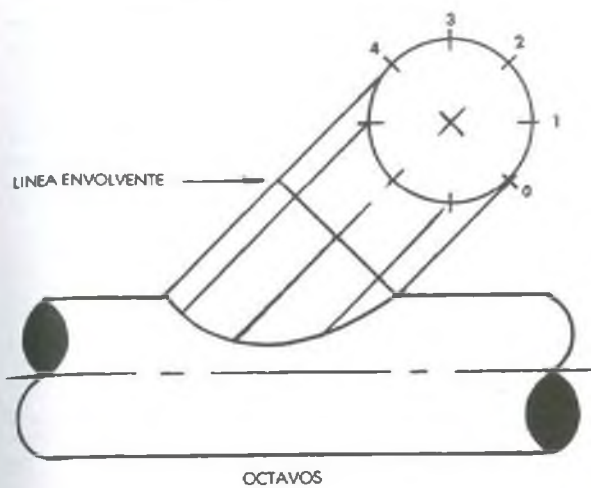

DERIVACIONES A 45°
TUBERIAS VERTICALES DE PESO ESTANDAR
MARCAR EN OCTAVOS
TAMAÑO DEL CABEZAL

	3"	4"	6"	8"	10"	12"	14"	16"	18"	20"	22"	24"	NO
Tub. ver. de 3"	1	$\frac{13}{16}$	$\frac{11}{16}$	$\frac{5}{8}$	$\frac{3}{8}$	$\frac{9}{16}$	$\frac{9}{16}$	$\frac{9}{16}$	$\frac{9}{16}$	$\frac{9}{16}$	$\frac{1}{2}$	$\frac{1}{2}$	1
	$2\frac{13}{16}$	2 $\frac{3}{8}$	2 $\frac{1}{2}$	2 $\frac{13}{16}$	2 $\frac{1}{4}$	2 $\frac{13}{16}$	2 $\frac{1}{4}$	2 $\frac{1}{4}$	2 $\frac{1}{4}$	2 $\frac{11}{16}$	2 $\frac{11}{16}$	2 $\frac{11}{16}$	2
	3 $\frac{1}{8}$	3	2 $\frac{7}{8}$	2 $\frac{13}{16}$	2 $\frac{3}{4}$	2 $\frac{5}{8}$	2 $\frac{3}{4}$	2 $\frac{3}{4}$	2 $\frac{11}{16}$	2 $\frac{11}{16}$	2 $\frac{11}{16}$	2 $\frac{11}{16}$	3
	3 $\frac{1}{2}$	3 $\frac{1}{2}$	3 $\frac{1}{4}$	3 $\frac{1}{2}$	3 $\frac{1}{2}$	3 $\frac{1}{2}$	3 $\frac{1}{2}$	3 $\frac{1}{2}$	3 $\frac{1}{2}$	3 $\frac{1}{2}$	3 $\frac{1}{2}$	3 $\frac{1}{2}$	4
Tub. ver. de 4"		$1\frac{1}{16}$	$1\frac{1}{4}$	$1\frac{15}{16}$	$\frac{7}{8}$	$1\frac{13}{16}$	$1\frac{13}{16}$	$\frac{3}{4}$	$\frac{3}{4}$	$\frac{3}{4}$	$\frac{3}{4}$	$1\frac{1}{16}$	1
		3 $\frac{3}{4}$	3	2 $\frac{11}{16}$	2 $\frac{9}{16}$	2 $\frac{1}{2}$	2 $\frac{1}{16}$	2 $\frac{3}{8}$	2 $\frac{5}{8}$	2 $\frac{5}{16}$	2 $\frac{1}{4}$	2 $\frac{1}{4}$	2
		4 $\frac{1}{8}$	3 $\frac{3}{4}$	3 $\frac{3}{4}$	3 $\frac{11}{16}$	3 $\frac{11}{16}$	3 $\frac{3}{8}$	3 $\frac{3}{8}$	3 $\frac{5}{8}$	3 $\frac{1}{16}$	3 $\frac{1}{8}$	3 $\frac{1}{8}$	3
		4	4	4	4	4	4	4	4	4	4	4	4
Tub. ver. de 6"			2	1 $\frac{11}{16}$	1 $\frac{1}{2}$	1 $\frac{3}{8}$	1 $\frac{3}{8}$	1 $\frac{5}{16}$	1 $\frac{1}{4}$	1 $\frac{1}{16}$	1 $\frac{1}{16}$	1 $\frac{1}{16}$	1
			5 $\frac{13}{16}$	4 $\frac{13}{16}$	4 $\frac{3}{8}$	4 $\frac{1}{8}$	4	3 $\frac{3}{8}$	3 $\frac{3}{4}$	3 $\frac{11}{16}$	3 $\frac{3}{8}$	3 $\frac{1}{16}$	2
			6 $\frac{1}{8}$	6	5 $\frac{13}{16}$	5 $\frac{11}{16}$	5 $\frac{1}{8}$	5 $\frac{1}{16}$	5 $\frac{1}{8}$	5 $\frac{1}{2}$	5 $\frac{1}{2}$	5 $\frac{1}{16}$	3
			6 $\frac{1}{16}$	6 $\frac{1}{16}$	6 $\frac{1}{16}$	6 $\frac{1}{16}$	6 $\frac{1}{16}$	6 $\frac{1}{16}$	6 $\frac{1}{16}$	6 $\frac{1}{16}$	6 $\frac{1}{16}$	6 $\frac{1}{16}$	4
Tub. ver. de 8"				2 $\frac{7}{8}$	2 $\frac{3}{4}$	2 $\frac{1}{2}$	2	1 $\frac{7}{8}$	1 $\frac{13}{16}$	1 $\frac{3}{8}$	1 $\frac{11}{16}$	1 $\frac{1}{8}$	1
				7 $\frac{3}{8}$	6 $\frac{3}{8}$	6	5 $\frac{1}{4}$	5 $\frac{1}{8}$	5 $\frac{1}{4}$	5 $\frac{1}{16}$	5 $\frac{1}{16}$	4 $\frac{15}{16}$	2
				8 $\frac{1}{8}$	7 $\frac{15}{16}$	7 $\frac{3}{4}$	7 $\frac{1}{2}$	7 $\frac{1}{8}$	7 $\frac{1}{8}$	7 $\frac{1}{8}$	7 $\frac{1}{8}$	7 $\frac{1}{8}$	3

DERIVACIONES A 45°
TUBERIAS VERTICALES DE PESO ESTANDAR
MARCAR EN DECISEISAVOS
TAMAÑO DEL CABEZAL

Tub. ver. de 10"	10"	12"	14"	16"	18"	20"	22"	24"	NO
	$\frac{1}{2}$	$\frac{11}{16}$	$\frac{3}{4}$	$\frac{13}{16}$	$\frac{15}{16}$	$\frac{17}{16}$	$\frac{3}{2}$	$\frac{5}{2}$	1
	3	2 $\frac{11}{16}$	2 $\frac{5}{8}$	2 $\frac{1}{2}$	2 $\frac{1}{2}$	2 $\frac{1}{2}$	2 $\frac{1}{2}$	2 $\frac{1}{2}$	2
	6 $\frac{11}{16}$	5 $\frac{15}{16}$	5 $\frac{9}{16}$	5 $\frac{1}{2}$	4 $\frac{1}{2}$	4 $\frac{11}{16}$	4 $\frac{9}{16}$	4 $\frac{1}{2}$	3
	9 $\frac{1}{16}$	8 $\frac{7}{16}$	8	7 $\frac{1}{2}$	7 $\frac{1}{2}$	6 $\frac{15}{16}$	6 $\frac{11}{16}$	6 $\frac{9}{16}$	4
	10 $\frac{11}{16}$	9 $\frac{9}{16}$	9 $\frac{1}{2}$	9	8 $\frac{1}{2}$	8 $\frac{1}{2}$	8 $\frac{1}{2}$	8 $\frac{1}{2}$	5
	10 $\frac{1}{16}$	10 $\frac{1}{16}$	9 $\frac{15}{16}$	9 $\frac{1}{2}$	9 $\frac{1}{2}$	9 $\frac{1}{2}$	9 $\frac{1}{2}$	9 $\frac{1}{2}$	6
	10 $\frac{1}{16}$	10 $\frac{1}{16}$	10	9 $\frac{15}{16}$	9 $\frac{15}{16}$	9 $\frac{1}{2}$	9 $\frac{1}{2}$	9 $\frac{1}{2}$	7
	10	10	10	10	10	10	10	10	8
	1 $\frac{1}{16}$	1	1 $\frac{15}{16}$	1 $\frac{1}{2}$	1 $\frac{1}{2}$	1 $\frac{13}{16}$	1 $\frac{11}{16}$	1 $\frac{3}{8}$	1
	4 $\frac{1}{16}$	3 $\frac{11}{16}$	3 $\frac{3}{8}$	3 $\frac{1}{2}$	3 $\frac{1}{2}$	2 $\frac{15}{16}$	2 $\frac{11}{16}$	2 $\frac{9}{16}$	2
	8 $\frac{1}{16}$	7 $\frac{1}{16}$	6 $\frac{3}{8}$	6 $\frac{1}{2}$	6 $\frac{1}{2}$	5 $\frac{11}{16}$	5 $\frac{7}{16}$	5 $\frac{3}{8}$	3
	12	10 $\frac{17}{16}$	9 $\frac{13}{16}$	9 $\frac{1}{2}$	8 $\frac{13}{16}$	8 $\frac{9}{16}$	8 $\frac{5}{16}$	8 $\frac{1}{8}$	4
	12 $\frac{1}{2}$	12 $\frac{1}{2}$	11 $\frac{15}{16}$	11	10 $\frac{11}{16}$	10 $\frac{7}{16}$	10 $\frac{3}{16}$	10 $\frac{1}{16}$	5
	12 $\frac{1}{2}$	12 $\frac{1}{2}$	11 $\frac{15}{16}$	11 $\frac{1}{2}$	11 $\frac{1}{2}$	11 $\frac{1}{2}$	11 $\frac{1}{2}$	11 $\frac{1}{2}$	6
	12 $\frac{1}{2}$	12 $\frac{1}{2}$	11 $\frac{15}{16}$	11 $\frac{15}{16}$	11 $\frac{15}{16}$	11 $\frac{15}{16}$	11 $\frac{15}{16}$	11 $\frac{15}{16}$	7
	12	12	12	12	12	12	12	12	8
	1 $\frac{3}{16}$	1 $\frac{1}{16}$	1	1 $\frac{15}{16}$	1 $\frac{13}{16}$	1 $\frac{11}{16}$	1 $\frac{9}{16}$	1 $\frac{7}{16}$	1
	4 $\frac{1}{8}$	3 $\frac{11}{16}$	3 $\frac{3}{8}$	3 $\frac{1}{2}$	3 $\frac{1}{2}$	2 $\frac{15}{16}$	2 $\frac{11}{16}$	2 $\frac{9}{16}$	2
	9 $\frac{1}{16}$	8 $\frac{1}{8}$	7 $\frac{1}{4}$	7 $\frac{1}{2}$	7 $\frac{1}{2}$	6 $\frac{3}{8}$	6 $\frac{1}{4}$	6 $\frac{1}{8}$	3
	13 $\frac{1}{16}$	11 $\frac{1}{8}$	10 $\frac{1}{2}$	10 $\frac{1}{4}$	9 $\frac{1}{2}$	9 $\frac{1}{4}$	9 $\frac{1}{8}$	9 $\frac{1}{16}$	4
	14 $\frac{1}{16}$	13 $\frac{1}{16}$	12 $\frac{1}{8}$	12 $\frac{1}{2}$	11 $\frac{17}{16}$	11 $\frac{13}{16}$	11 $\frac{9}{16}$	11 $\frac{5}{16}$	5
	13 $\frac{1}{8}$	13 $\frac{1}{16}$	12 $\frac{1}{8}$	12 $\frac{1}{2}$	12 $\frac{1}{2}$	12 $\frac{1}{2}$	12 $\frac{1}{2}$	12 $\frac{1}{2}$	6
	13 $\frac{1}{8}$	13 $\frac{1}{8}$	13 $\frac{1}{8}$	13 $\frac{1}{8}$	13 $\frac{1}{8}$	13 $\frac{1}{8}$	13 $\frac{1}{8}$	13 $\frac{1}{8}$	7
	13 $\frac{1}{8}$	13 $\frac{1}{8}$	13 $\frac{1}{8}$	13 $\frac{1}{8}$	13 $\frac{1}{8}$	13 $\frac{1}{8}$	13 $\frac{1}{8}$	13 $\frac{1}{8}$	8
	1 $\frac{1}{2}$	1 $\frac{1}{4}$	1 $\frac{1}{2}$	1 $\frac{3}{4}$	1 $\frac{1}{2}$	1 $\frac{1}{4}$	1 $\frac{1}{8}$	1 $\frac{1}{16}$	1
	5 $\frac{1}{8}$	4 $\frac{1}{2}$	4 $\frac{1}{4}$	4 $\frac{1}{4}$	4 $\frac{1}{4}$	4 $\frac{1}{4}$	4 $\frac{1}{4}$	4 $\frac{1}{4}$	2
	10 $\frac{11}{16}$	9 $\frac{1}{2}$	8 $\frac{13}{16}$	8 $\frac{1}{2}$	7 $\frac{15}{16}$	7 $\frac{11}{16}$	7 $\frac{7}{16}$	7 $\frac{3}{16}$	3
	15 $\frac{1}{2}$	13 $\frac{3}{8}$	12 $\frac{3}{4}$	12 $\frac{1}{2}$	12	11 $\frac{13}{16}$	11 $\frac{9}{16}$	11 $\frac{5}{16}$	4
	16 $\frac{1}{2}$	15 $\frac{1}{4}$	14 $\frac{1}{2}$	14 $\frac{1}{4}$	14 $\frac{1}{4}$	13 $\frac{13}{16}$	13 $\frac{9}{16}$	13 $\frac{5}{16}$	5
	17 $\frac{1}{2}$	15 $\frac{3}{4}$	15 $\frac{1}{2}$	15 $\frac{1}{4}$	15	14 $\frac{13}{16}$	14 $\frac{9}{16}$	14 $\frac{5}{16}$	6
	15 $\frac{3}{4}$	15 $\frac{1}{2}$	15 $\frac{1}{4}$	15 $\frac{1}{4}$	15 $\frac{1}{4}$	15 $\frac{1}{4}$	15 $\frac{1}{4}$	15 $\frac{1}{4}$	7
	15 $\frac{1}{4}$	15 $\frac{1}{4}$	15 $\frac{1}{4}$	15 $\frac{1}{4}$	15 $\frac{1}{4}$	15 $\frac{1}{4}$	15 $\frac{1}{4}$	15 $\frac{1}{4}$	8

**DERIVACIONES A 45°
TUBERIAS VERTICALES DE PESO ESTANDAR
MARCAR EN DIECISEISAVOS
TAMANO DEL CABEZAL**

Tub. ver. de	18"	20"	22"	24"	No
18"	1 1/4	1 1/4	1 1/2	1 3/4	1
	5/8	5/8	5/8	4/8	2
	1 1/2	10 1/2	10 1/4	9 1/4	3
	1 7/8	15 1/4	14 1/2	13 1/4	4
	1 8 1/4	17 1/2	16 1/2	16 1/4	5
	1 8 1/2	17 1/4	17 1/2	17 1/4	6
	1 7 1/2	17 1/2	17 1/4	17 1/4	7
	1 7 1/4	17 1/2	17 1/2	17 1/2	8
20"	1 1/2	1 1/2	1 1/2	1 1/2	1
	6 1/4	6 1/4	6 1/4	5 1/2	2
	1 3 1/4	12 1/2	11 1/2	11 1/4	3
	19 1/4	17 1/2	16 1/2	16 1/4	4
	21	19 1/2	18 1/2	18 1/4	5
	20 1/4	19 1/2	19 1/4	19 1/4	6
	19 1/4	19 1/4	19 1/4	19 1/4	7
	19 1/4	19 1/4	19 1/4	19 1/4	8
	1 1/2	1 1/2	1 1/2	1 1/2	1
	7 1/4	7 1/4	6 1/4	6 1/4	2
22"	1 5/8	1 5/8	1 3/4	1 3/4	3
	2 1/4	2 1/4	1 9 1/4	1 9 1/4	4
	2 3 1/4	2 1 1/4	2 1 1/4	2 1 1/4	5
	2 2 1/4	2 1 1/4	2 1 1/4	2 1 1/4	6
	2 1 1/4	2 1 1/4	2 1 1/4	2 1 1/4	7
	2 1 1/4	2 1 1/4	2 1 1/4	2 1 1/4	8
	2 1/4	2 1/4	2 1/4	2 1/4	1
	8	8	16 1/4	16 1/4	2
24"	2 3/4	2 3/4	2 3/4	2 3/4	3
	2 5 1/4	2 5 1/4	2 5 1/4	2 5 1/4	4
	2 5 1/4	2 5 1/4	2 5 1/4	2 5 1/4	5
	2 4 1/4	2 4 1/4	2 4 1/4	2 4 1/4	6
	2 3 1/4	2 3 1/4	2 3 1/4	2 3 1/4	7
2 3 1/4	2 3 1/4	2 3 1/4	2 3 1/4	8	

**TIPO # 3
EXCENTRICO EN EL
RADIO INTERIOR
DEL CODO**

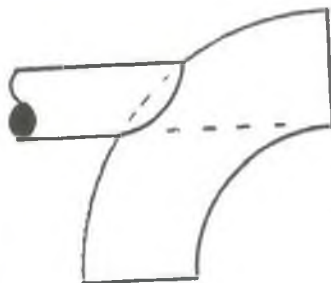

**TIPO # 2
EXCENTRICO EN EL
RADIO EXTERIOR
DEL CODO**

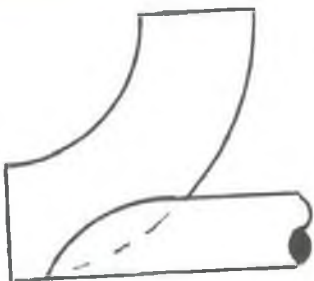

**TIPO # 1
CONCENTRICO CON
LA LINEA DE CENTRO DEL
RADIO DEL CODO**

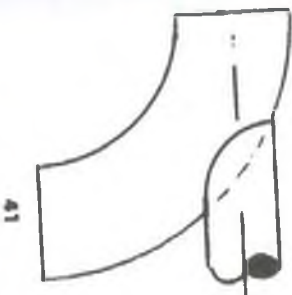

ESTOS TRES TIPOS DE ASIENTOS EN CODOS SOLDABLES DE RADIO LARGO A 90°, REQUIEREN DIMENSIONES DIFERENTES. SIN EMBARGO, EL TRAZADO DE CADA TIPO ES COMUN Y SE MUESTRA EN LA PAGINA SIGUIENTE. PARA MARCAR LOS TAMAÑOS PEQUEÑOS EN OCTAVOS, SE USAN LAS ORDENADAS # 0-2-4-5-8.

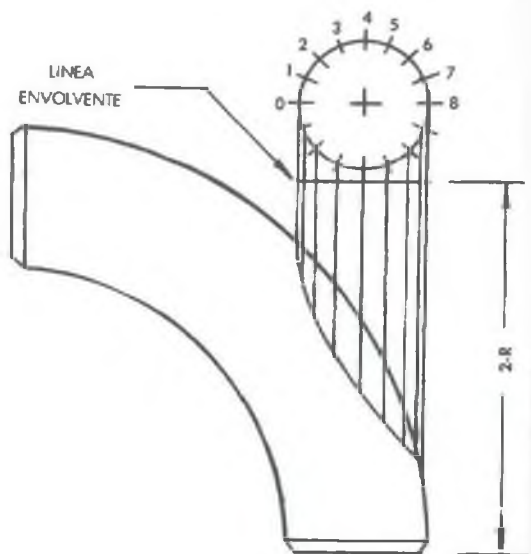

TRAZADO DE UN ASIENTO CONCENTRICO O
EXCENTRICO EN EL DORSO DE UN CODO
A 90° DE RADIO LARGO

Se marca en dieciseisavos y se mide a partir de una línea envolvente, que es la longitud de dos radios desde el extremo del codo. Ejemplo: un codo de 6" de radio largo tiene un radio de 9", de modo que la línea envolvente será de 18".

ASIENTO CONCENTRICO EN EL DORSO DE UN CODO DE RADIO LARGO A 90°
 (TIPO # 1) TUBERIA DE PESO ESTANDAR
 L/C DEL ASIENTO CON L/C DEL CODO

TAMAÑO DEL CODO								
	2"	3"	4"	6"	8"	10"	12"	No
Tub. de 2"	2 $\frac{1}{4}$ ₁₆	3 $\frac{13}{16}$	5 $\frac{7}{16}$	8 $\frac{3}{8}$	11 $\frac{15}{16}$	15 $\frac{1}{16}$	18 $\frac{1}{2}$	0
	2 $\frac{1}{2}$ ₁₆	3 $\frac{5}{8}$ ₁₆	5 $\frac{1}{2}$	8 $\frac{11}{16}$	12	15 $\frac{1}{8}$	18 $\frac{9}{16}$	1
	2 $\frac{3}{4}$ ₁₆	4 $\frac{1}{8}$ ₁₆	5 $\frac{13}{16}$	9	12 $\frac{3}{8}$	15 $\frac{1}{2}$	18 $\frac{3}{8}$	2
	3 $\frac{1}{8}$	4 $\frac{11}{16}$	6 $\frac{1}{8}$	9 $\frac{3}{4}$	12 $\frac{11}{16}$	15 $\frac{5}{8}$	19 $\frac{1}{4}$	3
	4 $\frac{1}{8}$ ₁₆	5 $\frac{1}{8}$ ₁₆	6 $\frac{11}{16}$	9 $\frac{13}{16}$	13 $\frac{1}{8}$	16 $\frac{3}{16}$	19 $\frac{11}{16}$	4
	4 $\frac{1}{2}$	5 $\frac{9}{16}$	7 $\frac{3}{8}$	10 $\frac{1}{4}$	13 $\frac{9}{16}$	16 $\frac{13}{16}$	20 $\frac{1}{8}$	5
	4 $\frac{3}{4}$	5 $\frac{7}{8}$	7 $\frac{7}{16}$	10 $\frac{9}{16}$	13 $\frac{3}{8}$	17 $\frac{1}{2}$	20 $\frac{1}{2}$	6
	4 $\frac{7}{8}$	6 $\frac{1}{16}$	7 $\frac{5}{8}$	10 $\frac{3}{4}$	14 $\frac{3}{8}$	17 $\frac{3}{8}$	20 $\frac{11}{16}$	7
	4 $\frac{15}{16}$	6 $\frac{3}{8}$	7 $\frac{13}{16}$	10 $\frac{7}{8}$	14 $\frac{1}{4}$	17 $\frac{1}{4}$	20 $\frac{3}{4}$	8
Tub. de 3"		3 $\frac{1}{2}$	5 $\frac{1}{16}$	8 $\frac{3}{16}$	11 $\frac{1}{2}$	14 $\frac{11}{16}$	18	0
		3 $\frac{11}{16}$	5 $\frac{1}{4}$	8 $\frac{3}{8}$	11 $\frac{5}{8}$	14 $\frac{7}{8}$	18 $\frac{1}{2}$	1
		4 $\frac{1}{4}$	5 $\frac{3}{4}$	8 $\frac{13}{16}$	12 $\frac{1}{16}$	15 $\frac{1}{4}$	18 $\frac{9}{16}$	2
		5 $\frac{1}{8}$	6 $\frac{1}{16}$	9 $\frac{7}{16}$	12 $\frac{11}{16}$	15 $\frac{3}{8}$	19 $\frac{1}{8}$	3
		6 $\frac{1}{8}$	7 $\frac{1}{4}$	10 $\frac{3}{16}$	13 $\frac{3}{8}$	16 $\frac{9}{16}$	19 $\frac{11}{16}$	4
		6 $\frac{13}{16}$	7 $\frac{15}{16}$	10 $\frac{13}{16}$	14	17 $\frac{3}{16}$	20 $\frac{1}{2}$	5
		7 $\frac{3}{16}$	8 $\frac{3}{8}$	11 $\frac{1}{4}$	14 $\frac{1}{2}$	17 $\frac{11}{16}$	21	6
		7 $\frac{5}{16}$	8 $\frac{9}{16}$	11 $\frac{9}{16}$	14 $\frac{13}{16}$	18	21 $\frac{1}{16}$	7
Tub. de 4"			4 $\frac{3}{4}$	7 $\frac{7}{8}$	11 $\frac{1}{8}$	14 $\frac{1}{16}$	17 $\frac{3}{8}$	0
			5	8 $\frac{1}{16}$	11 $\frac{15}{16}$	14 $\frac{1}{2}$	17 $\frac{11}{16}$	1
			5 $\frac{3}{4}$	8 $\frac{11}{16}$	11 $\frac{1}{8}$	15 $\frac{1}{16}$	18 $\frac{3}{8}$	2
			6 $\frac{13}{16}$	9 $\frac{5}{8}$	12 $\frac{3}{8}$	15 $\frac{3}{8}$	19 $\frac{1}{8}$	3
			8 $\frac{3}{8}$	10 $\frac{5}{8}$	13 $\frac{11}{16}$	16 $\frac{13}{16}$	20 $\frac{1}{16}$	4
			9 $\frac{1}{8}$	11 $\frac{1}{2}$	14 $\frac{1}{16}$	17 $\frac{5}{8}$	20 $\frac{3}{8}$	5
			9 $\frac{13}{16}$	12 $\frac{1}{16}$	15 $\frac{1}{16}$	18 $\frac{1}{4}$	21 $\frac{9}{16}$	6
			10	12 $\frac{3}{8}$	15 $\frac{1}{2}$	18 $\frac{11}{16}$	21 $\frac{11}{16}$	7
Tub. de 6"			10 $\frac{1}{16}$	12 $\frac{1}{2}$	15 $\frac{3}{8}$	18 $\frac{13}{16}$	22 $\frac{1}{16}$	8
				7 $\frac{1}{4}$	10 $\frac{3}{8}$	13 $\frac{1}{2}$	16 $\frac{1}{4}$	0
				7 $\frac{5}{8}$	10 $\frac{1}{4}$	13 $\frac{13}{16}$	17 $\frac{1}{16}$	1
				8 $\frac{3}{8}$	11 $\frac{1}{4}$	14 $\frac{1}{4}$	18	2
				10 $\frac{5}{8}$	13 $\frac{1}{4}$	16 $\frac{3}{8}$	19 $\frac{1}{8}$	3
				12 $\frac{15}{16}$	14 $\frac{3}{8}$	17 $\frac{5}{8}$	20 $\frac{1}{4}$	4
				14 $\frac{7}{16}$	16 $\frac{1}{8}$	18 $\frac{5}{16}$	22	5
				15 $\frac{1}{16}$	17 $\frac{1}{8}$	19 $\frac{11}{16}$	22 $\frac{5}{16}$	6
			15 $\frac{1}{8}$	17 $\frac{1}{16}$	20 $\frac{3}{8}$	23 $\frac{1}{2}$	7	
			15 $\frac{3}{8}$	17 $\frac{1}{4}$	20 $\frac{1}{2}$	23 $\frac{11}{16}$	8	

ASIENTO CONCENTRICO EN EL DORSO DE UN CODO DE RADIO LARGO A 90° (TIPO # 1) TUBERIA DE PESO ESTANDAR L/C DEL ASIENTO CON L/C DEL CODO

		TAMAÑO DEL CODO							
		8"	10"	12"	14"	16"	18"	20"	No
Tub. de 8"	9 ¹¹ / ₁₆	12 ⁷ / ₁₆	16 ¹ / ₁₆	19 ³ / ₁₆	23	26 ⁵ / ₁₆	29 ⁷ / ₁₆	30	0
	10 ¹ / ₁₆	13 ³ / ₁₆	16 ³ / ₁₆	20 ⁵ / ₁₆	23 ⁷ / ₁₆	26 ⁷ / ₁₆	30	1	
	11 ³ / ₁₆	14 ⁵ / ₁₆	17 ⁵ / ₁₆	21 ⁷ / ₁₆	24 ⁹ / ₁₆	27 ¹¹ / ₁₆	31 ¹³ / ₁₆	2	
	14 ³ / ₈	16 ³ / ₈	19 ¹ / ₈	23 ³ / ₈	26 ⁵ / ₈	29 ⁷ / ₈	32 ⁹ / ₈	3	
	17 ¹ / ₂	19	21 ¹ / ₄	25 ¹ / ₄	28 ¹ / ₂	31 ³ / ₄	34 ⁵ / ₄	4	
	19 ³ / ₈	20 ¹ / ₂	23 ¹ / ₂	27 ³ / ₈	30 ⁵ / ₈	33 ⁷ / ₈	36 ⁹ / ₈	5	
	20 ³ / ₈	21 ³ / ₈	24 ³ / ₈	28 ³ / ₈	31 ⁵ / ₈	34 ⁷ / ₈	37 ⁹ / ₈	6	
	20 ¹ / ₂	22 ¹ / ₈	25 ³ / ₈	29 ⁵ / ₈	32 ⁷ / ₈	35 ⁹ / ₈	38 ¹¹ / ₈	7	
	20 ³ / ₄	22 ³ / ₈	25 ⁵ / ₈	29 ⁷ / ₈	32 ⁹ / ₈	35 ¹¹ / ₈	38 ¹³ / ₈	8	
Tub. de 10"		12 ¹ / ₂	15 ³ / ₄	19	22 ¹ / ₂	25 ³ / ₄	28 ⁵ / ₄	0	
		12 ³ / ₈	16	19 ³ / ₈	22 ⁵ / ₈	26 ⁷ / ₈	29 ⁹ / ₈	1	
		14 ¹ / ₈	17 ³ / ₈	21 ⁵ / ₈	24 ⁷ / ₈	27 ⁹ / ₈	30 ¹¹ / ₈	2	
		18	20 ¹ / ₈	24	26 ¹ / ₈	30	33 ³ / ₈	3	
		22 ³ / ₈	23 ⁵ / ₈	26 ⁷ / ₈	29 ⁹ / ₈	32 ¹¹ / ₈	35 ¹³ / ₈	4	
		24 ¹ / ₄	25 ³ / ₄	29 ⁵ / ₄	31 ⁷ / ₄	34 ⁹ / ₄	37 ¹¹ / ₄	5	
		25 ¹ / ₄	27 ³ / ₄	30 ⁵ / ₄	33 ⁷ / ₄	36 ⁹ / ₄	39 ¹¹ / ₄	6	
		26 ³ / ₄	27 ⁵ / ₄	31 ⁷ / ₄	34 ⁹ / ₄	37 ¹¹ / ₄	40 ¹³ / ₄	7	
		26 ⁵ / ₄	27 ⁷ / ₄	31 ⁹ / ₄	34 ¹¹ / ₄	37 ¹³ / ₄	40 ¹⁵ / ₄	8	
Tub. de 12"			14 ³ / ₄	18 ⁵ / ₄	21 ⁷ / ₄	24 ⁹ / ₄	28	0	
			15 ¹ / ₄	19 ³ / ₄	22 ⁵ / ₄	25 ⁷ / ₄	28 ¹ / ₄	1	
			17 ³ / ₄	21 ⁵ / ₄	24 ⁷ / ₄	27 ⁹ / ₄	30 ¹¹ / ₄	2	
			21 ¹ / ₄	25	27 ³ / ₄	30 ⁵ / ₄	33 ⁷ / ₄	3	
			26 ¹ / ₄	29 ³ / ₄	31 ⁵ / ₄	33 ⁷ / ₄	36 ⁹ / ₄	4	
			30 ³ / ₄	32 ⁵ / ₄	34 ⁷ / ₄	36 ⁹ / ₄	39 ¹¹ / ₄	5	
			31 ¹ / ₄	33 ³ / ₄	35 ⁵ / ₄	38 ⁷ / ₄	41 ⁹ / ₄	6	
			31 ³ / ₄	34 ⁵ / ₄	36 ⁷ / ₄	39 ⁹ / ₄	42 ¹¹ / ₄	7	
			31 ⁵ / ₄	34 ⁷ / ₄	36 ⁹ / ₄	39 ¹¹ / ₄	42 ¹³ / ₄	8	
Tub. de 14"				18	21 ¹ / ₂	24 ³ / ₂	27 ⁵ / ₂	0	
				18 ¹ / ₄	21 ³ / ₄	25 ⁵ / ₄	28 ⁷ / ₄	1	
				21 ¹ / ₂	24 ¹ / ₄	27 ³ / ₄	30 ⁵ / ₄	2	
				26 ³ / ₈	28 ¹ / ₄	31	33 ³ / ₄	3	
				32	32 ¹ / ₄	34 ³ / ₂	37 ⁵ / ₂	4	
				35 ¹ / ₄	35 ³ / ₄	38	40 ¹ / ₂	5	
				36 ¹ / ₄	37 ¹ / ₄	39 ³ / ₂	42 ⁵ / ₂	6	
				37 ³ / ₈	38 ¹ / ₂	40 ¹ / ₂	43 ³ / ₄	7	
				37 ⁵ / ₈	38 ³ / ₄	41 ¹ / ₂	43 ⁵ / ₄	8	

ASIENTO CONCENTRICO EN EL DORSO DE UN CODO DE RADIO LARGO A 90° (TIPO # 1) TUBERIA DE PESO ESTANDAR L/C DEL ASIENTO CON L/C DEL CODO

		TAMAÑO DEL CODO					
		16"	18"	20"	22"	24"	No
Tub. de 16"		20 ¹ / ₂	23 ¹ / ₄	26 ¹ / ₂	30 ¹ / ₄	33 ¹ / ₂	0
		21 ¹ / ₂	24 ³ / ₈	27 ³ / ₄	30 ³ / ₄	34 ³ / ₈	1
		24 ¹ / ₄	27 ¹ / ₂	30 ¹ / ₂	33 ¹ / ₄	36 ¹ / ₂	2
		29 ⁷ / ₈	32	34 ³ / ₈	37 ¹ / ₂	40 ¹ / ₄	3
		36 ¹ / ₂	37 ¹ / ₄	39 ¹ / ₂	41 ¹ / ₂	44 ¹ / ₄	4
		41 ¹ / ₈	41 ¹ / ₈	42 ³ / ₈	45 ³ / ₈	48	5
		42 ¹ / ₄	43	45 ¹ / ₄	47 ¹ / ₄	50 ¹ / ₄	6
		43	43 ³ / ₈	46 ³ / ₈	48 ³ / ₄	51 ¹ / ₈	7
		43 ⁵ / ₈	44 ³ / ₈	46 ⁵ / ₈	49 ³ / ₈	52	8
			23 ³ / ₈	26 ³ / ₈	29 ³ / ₈	32 ³ / ₈	0
Tub. de 18"			24 ¹ / ₈	27 ³ / ₈	30 ⁵ / ₈	33 ⁷ / ₈	1
			27 ¹ / ₈	30 ³ / ₈	33 ⁵ / ₈	36 ⁷ / ₈	2
			33 ³ / ₈	35 ⁵ / ₈	38 ⁷ / ₈	41 ⁹ / ₈	3
			41 ¹ / ₈	41 ³ / ₈	43 ⁵ / ₈	46 ⁷ / ₈	4
			46 ³ / ₈	46 ⁵ / ₈	47 ⁷ / ₈	50 ⁹ / ₈	5
			48 ¹ / ₈	48 ³ / ₈	50 ⁵ / ₈	52 ⁷ / ₈	6
			48 ³ / ₈	49 ⁵ / ₈	51 ⁷ / ₈	53 ⁹ / ₈	7
			48 ⁵ / ₈	49 ⁷ / ₈	51 ⁹ / ₈	54 ¹¹ / ₈	8
				25 ¹ / ₄	28 ³ / ₄	31 ⁵ / ₄	0
	Tub. de 20"			26 ¹ / ₄	29 ³ / ₄	33 ⁵ / ₄	1
			30 ¹ / ₄	33 ³ / ₄	36 ⁵ / ₄	2	
			37 ¹ / ₄	39 ³ / ₄	42 ⁵ / ₄	3	
			46 ¹ / ₄	46 ³ / ₄	48 ⁵ / ₄	4	
			52 ¹ / ₄	51 ³ / ₄	52 ⁵ / ₄	5	
			53 ¹ / ₄	53 ³ / ₄	55 ⁵ / ₄	6	
			54 ¹ / ₄	54 ³ / ₄	56 ⁵ / ₄	7	
			54 ³ / ₄	55 ⁵ / ₄	57 ⁷ / ₄	8	
				28 ¹ / ₂	31 ¹ / ₂	0	
Tub. de 22"				29 ¹ / ₂	32 ¹ / ₂	1	
			33 ¹ / ₄	36 ¹ / ₄	2		
			41 ¹ / ₄	43 ³ / ₄	3		
			52	51 ¹ / ₄	4		
			57 ¹ / ₄	56 ¹ / ₂	5		
			59 ¹ / ₂	59 ¹ / ₄	6		
			60 ¹ / ₂	60 ¹ / ₄	7		
			60 ³ / ₄	60 ¹ / ₂	8		

ASIENTO EXCENTRICO EN EL DORSO DE UN CODO DE RADIO LARGO A 90°
(TIPO # 2) TUBERIA DE PESO ESTANDAR
LA BASE DEL TUBO SE ALINEA CON EL RADIO EXTERIOR DEL CODO

		TAMAÑO DEL CODO						
		3"	4"	6"	8"	10"	12"	NO
Tub. de 2"		4 1/4	6 3/8	10 15/16	15 3/16	20 3/4	25 13/16	0
		4 3/8	6 1/2	11 3/8	15 15/16	20 15/16	26 3/8	1
		4 1/2	6 3/4	11 3/4	16 7/16	21 1/2	26 5/8	2
		5 1/16	7 1/2	12 1/4	17 1/4	22 1/2	27 3/8	3
		5 13/16	8 1/4	13 1/8	18 1/4	23 1/8	28 3/4	4
		6 3/8	9	14 1/4	19 5/8	24 11/16	30 3/8	5
		7 1/8	9 11/16	15	20 1/4	25 15/16	31 1/2	6
		7 3/8	10 3/8	15 3/4	21 3/8	27	32 1/2	7
Tub. de 3"		7 5/8	10 1/4	16 1/4	21 3/8	27 1/2	33 3/4	8
			5 7/8	9 3/8	14 3/8	18 15/16	23 3/4	0
			5 5/8	9 13/16	14 7/8	19 3/8	24 3/8	1
			6 1/8	10 7/16	15 1/8	19 3/4	24 13/16	2
			7	11 5/16	16 1/8	20 3/4	25 15/16	3
			8	12 1/4	17 3/8	22 5/8	27 7/8	4
			8 7/8	13 3/8	18 3/8	23 13/16	29 3/8	5
			9 5/8	14 5/8	19 5/16	25 3/8	30 3/8	6
Tub. de 4"		10	15 3/8	20 15/16	26 1/2	32 3/8	37 3/8	7
		10 1/4	15 11/16	21 1/4	27 1/8	32 3/4	38 1/4	8
			8 11/16	13	17 1/2	22 3/4	28 1/2	0
			8 15/16	13 3/8	17 13/16	22 5/8	29 1/4	1
			9 11/16	14 1/16	18 11/16	23 7/16	29 3/4	2
			10 13/16	15 3/16	20	24 13/16	30 3/4	3
			12 3/16	16 3/8	21 9/16	26 9/16	32 1/2	4
			13 3/8	18 3/16	23 3/16	28 1/2	34 1/2	5
Tub. de 6"			14 3/8	19 11/16	25	30 3/8	36 3/8	6
			15 3/16	20 13/16	26 5/16	31 13/16	37 3/8	7
			15 3/8	21 1/8	26 3/4	32 3/8	38 1/4	8
				11 3/8	15 1/4	19 5/8	24 1/2	0
				11 3/4	15 3/4	20	25 1/2	1
				12 3/8	16 13/16	21 3/8	26 3/4	2
				14 3/16	18 3/16	23 1/16	28 3/16	3
				16 3/8	20 11/16	25 3/8	30 3/8	4
Tub. de 8"			18 1/4	22 13/16	27 11/16	32 1/2	37 1/2	5
			19 11/16	24 13/16	29 3/4	34 3/4	40 1/4	6
			20 3/8	26 1/8	31 3/8	36 3/8	42 1/4	7
			21	26 3/4	32 3/4	38 1/4	44 1/4	8

ASIENTO EXCENTRICO EN EL DORSO DE UN CODO DE RADIO LARGO A 90°
(TIPO # 2) TUBERIA DE PESO ESTANDAR
LA BASE DEL TUBO SE ALINEA CON EL RADIO EXTERIOR DEL CODO

		TAMAÑO DEL CODO						
		10"	12"	14"	16"	18"	20"	NO
Tub. de 8"		13 3/8	17 11/16	22 3/8	26 3/8	31	35 3/8	0
		14 3/8	18 3/8	22 5/8	27 1/4	31 3/8	36 3/8	1
		15 3/8	19 1/8	24 1/4	28 11/16	33 3/8	37 13/16	2
		17 3/8	22 3/8	26 11/16	31 3/8	35 13/16	40 9/16	3
		20 3/8	24 13/16	29 3/8	34 3/8	39	43 3/8	4
		24 3/8	27 3/8	32 3/8	37 3/8	42 3/8	47 3/8	5
		26	29 3/8	35 3/8	40 3/8	45 3/8	50 13/16	6
		26	31 3/8	37	42 3/8	48 1/8	53 3/8	7
Tub. de 10"		26 3/8	32 3/8	37 3/8	43 3/8	49 3/8	54 13/16	8
			16 1/16	20 3/8	24 3/8	28 11/16	33 3/8	0
			16 13/16	20 3/4	25 3/8	29 3/8	33 13/16	1
			18 3/8	22 3/8	27 3/8	31 3/8	35 3/8	2
			21 3/8	25 3/8	30 3/8	34 3/8	39	3
			25	29 3/8	33 11/16	38 3/8	42 3/8	4
			28 3/8	32 11/16	37 3/8	41 3/8	46 3/8	5
			30 3/8	35 3/8	40 3/8	45 3/8	50 3/8	6
Tub. de 12"			31 3/8	36 3/8	42 3/8	47 13/16	53 3/8	7
			31 13/16	37 3/8	43 3/8	48 3/8	54 3/8	8
			18 3/8	22 3/8	26 13/16	31 3/8	36 3/8	0
			19 3/8	23 3/8	27 3/8	31 3/8	37 3/8	1
			21 13/16	25 3/8	30	34 3/8	39 3/8	2
			25 13/16	29 3/8	33 3/8	37 13/16	42 3/8	3
			30 3/8	33 13/16	37 13/16	42 3/8	47 3/8	4
			33 13/16	37 13/16	42 3/8	46 3/8	51 3/8	5
Tub. de 14"			35 13/16	40 3/8	45 3/8	50 3/8	55 3/8	6
			37 3/8	42 3/8	47 3/8	53 3/8	59 3/8	7
			37 3/8	43 3/8	48 13/16	54 3/8	60 3/8	8
				21 13/16	25 13/16	29 13/16	33 13/16	0
				22 11/16	26 11/16	30 13/16	34 13/16	1
				25 3/8	29 3/8	33 3/8	37 3/8	2
				29 3/8	33 3/8	37 3/8	41 3/8	3
				34 3/8	38 3/8	42 3/8	46 3/8	4
Tub. de 16"			38 3/8	42 3/8	46 13/16	50 3/8	54 3/8	5
			41 3/16	45 3/8	50 3/8	54 3/8	58 3/8	6
			42 3/8	47 3/8	51 3/8	55 3/8	59 3/8	7
			43 3/8	48 13/16	52 3/8	56 3/8	60 3/8	8

ASIENTO EXCENTRICO EN EL DORSO DE UN CODO DE RADIO LARGO A 90° (TIPO # 2) TUBERIA DE PESO ESTANDAR
 LA BASE DEL TUBO SE ALINEA CON EL RADIO EXTERIOR DEL CODO

		TAMAÑO DEL CODO				
		18"	20"	22"	24"	No
Tub. de 16"		18"	20"	22"	24"	No
		24 ⁵ / ₈ "	28 ¹ / ₄ "	32 ³ / ₈ "	36 ⁹ / ₈ "	0
		25 ³ / ₄ "	29 ¹ / ₂ "	33 ¹ / ₂ "	37 ³ / ₈ "	1
		28 ³ / ₈ "	32 ¹ / ₄ "	36 ³ / ₈ "	40 ³ / ₈ "	2
		33 ³ / ₄ "	36 ¹ / ₂ "	41	45 ¹ / ₂ "	3
		38 ¹ / ₂ "	42 ¹ / ₂ "	46 ¹ / ₂ "	50 ¹ / ₂ "	4
		43 ¹ / ₄ "	47 ¹ / ₂ "	51 ³ / ₄ "	56 ³ / ₄ "	5
		46 ⁹ / ₈ "	51 ¹ / ₂ "	56	60 ¹ / ₂ "	6
Tub. de 18"		48 ¹ / ₂ "	53 ¹ / ₂ "	59	64 ¹ / ₂ "	7
		48 ¹ / ₂ "	54 ³ / ₈ "	60 ³ / ₈ "	66	8
			26 ¹ / ₄ "	30 ¹ / ₂ "	34 ¹ / ₄ "	0
			28	31 ¹ / ₂ "	36	1
			31 ¹ / ₂ "	35 ³ / ₈ "	39 ³ / ₈ "	2
			36 ¹ / ₂ "	40 ¹ / ₂ "	44 ³ / ₈ "	3
			43 ³ / ₈ "	47	50 ³ / ₈ "	4
			48 ¹ / ₂ "	52 ⁹ / ₈ "	56 ³ / ₄ "	5
Tub. de 20"			52 ³ / ₈ "	56 ³ / ₈ "	61 ³ / ₈ "	6
			53 ¹ / ₄ "	59 ¹ / ₄ "	64 ¹ / ₄ "	7
			54 ¹ / ₄ "	60 ¹ / ₄ "	66	8
				29 ³ / ₈ "	33 ³ / ₈ "	0
				30 ³ / ₈ "	34 ³ / ₈ "	1
				34 ¹ / ₈ "	38 ³ / ₈ "	2
				40 ¹ / ₈ "	44 ³ / ₈ "	3
				48 ³ / ₈ "	51 ³ / ₈ "	4
Tub. de 22"			54 ³ / ₈ "	57 ³ / ₈ "	62 ³ / ₈ "	5
				57 ¹ / ₂ "	62 ³ / ₈ "	6
				59 ³ / ₈ "	64 ¹ / ₈ "	7
				60 ³ / ₈ "	66	8
					31 ³ / ₈ "	0
					33 ³ / ₈ "	1
					37 ³ / ₈ "	2
					44 ³ / ₈ "	3
				53 ¹ / ₈ "	4	
				59 ³ / ₈ "	5	
				63 ³ / ₈ "	6	
				65 ³ / ₈ "	7	
				66	8	

ASIENTO EXCENTRICO EN EL DORSO DE UN CODO DE RADIO LARGO A 90° (TIPO # 3) TUBERIA DE PESO ESTANDAR
 LA BASE DEL TUBO SE ALINEA CON EL RADIO EXTERIOR DEL CODO

		TAMAÑO DEL CODO						
		3"	4"	6"	8"	10"	12"	No.
Tub. de 2'		3 ¹ / ₈ "	4 ¹ / ₂ "	7 ¹ / ₈ "	9 ¹ / ₈ "	12 ¹ / ₈ "	14 ¹ / ₈ "	0
		3 ¹ / ₈ "	4 ¹ / ₂ "	7 ¹ / ₈ "	9 ¹ / ₈ "	12 ¹ / ₈ "	14 ¹ / ₈ "	1
		3 ¹ / ₈ "	5 ¹ / ₈ "	7 ¹ / ₈ "	9 ¹ / ₈ "	12 ¹ / ₈ "	14 ¹ / ₈ "	2
		4 ¹ / ₈ "	5 ³ / ₈ "	7 ¹ / ₈ "	10 ¹ / ₈ "	12 ¹ / ₈ "	15 ¹ / ₈ "	3
		4 ¹ / ₈ "	5 ¹ / ₂ "	8	10 ¹ / ₈ "	12 ¹ / ₈ "	15 ¹ / ₈ "	4
		4 ¹ / ₈ "	6	8 ¹ / ₄ "	10 ¹ / ₈ "	13 ¹ / ₈ "	15 ¹ / ₈ "	5
		5 ¹ / ₈ "	6 ³ / ₈ "	8 ³ / ₈ "	10 ¹ / ₈ "	13 ¹ / ₈ "	15 ¹ / ₈ "	6
		5 ¹ / ₈ "	6 ¹ / ₄ "	8 ¹ / ₂ "	11	13 ¹ / ₈ "	15 ¹ / ₈ "	7
Tub. de 3"		5 ¹ / ₈ "	6 ³ / ₈ "	8 ³ / ₈ "	11 ¹ / ₈ "	13 ¹ / ₈ "	15 ¹ / ₈ "	8
			4 ¹ / ₂ "	7 ¹ / ₈ "	9 ³ / ₈ "	12 ³ / ₈ "	14 ³ / ₈ "	0
			4 ¹ / ₂ "	7 ¹ / ₈ "	9 ¹ / ₈ "	12 ³ / ₈ "	14 ³ / ₈ "	1
			5 ³ / ₈ "	7 ¹ / ₈ "	10 ³ / ₈ "	12 ³ / ₈ "	15 ³ / ₈ "	2
			6	8 ¹ / ₄ "	10 ³ / ₈ "	12 ³ / ₈ "	15 ³ / ₈ "	3
			6 ¹ / ₈ "	8 ¹ / ₈ "	11 ¹ / ₈ "	13 ¹ / ₈ "	15 ³ / ₈ "	4
			7 ¹ / ₈ "	9 ³ / ₈ "	11 ¹ / ₈ "	13 ¹ / ₈ "	16 ¹ / ₈ "	5
			7 ¹ / ₂ "	9 ³ / ₈ "	11 ¹ / ₈ "	14	16 ¹ / ₈ "	6
Tub. de 4"			7 ³ / ₈ "	9 ³ / ₈ "	11 ¹ / ₈ "	14 ¹ / ₈ "	16 ¹ / ₈ "	7
			7 ³ / ₈ "	9 ³ / ₈ "	11 ¹ / ₈ "	14 ¹ / ₈ "	16 ¹ / ₈ "	8
			7 ¹ / ₂ "	9 ³ / ₈ "	11 ¹ / ₈ "	12 ³ / ₈ "	14 ³ / ₈ "	0
			7 ¹ / ₂ "	9 ¹ / ₂ "	11 ¹ / ₈ "	12 ³ / ₈ "	14 ³ / ₈ "	1
			7 ¹ / ₂ "	9 ¹ / ₂ "	11 ¹ / ₈ "	12 ³ / ₈ "	15 ³ / ₈ "	2
			8 ¹ / ₈ "	11	13 ¹ / ₈ "	15 ³ / ₈ "	17 ³ / ₈ "	3
			9 ¹ / ₂ "	11 ¹ / ₈ "	13 ¹ / ₈ "	16 ³ / ₈ "	18 ³ / ₈ "	4
			10 ¹ / ₈ "	12 ³ / ₈ "	14 ¹ / ₈ "	16 ³ / ₈ "	18 ³ / ₈ "	5
Tub. de 6"			10 ¹ / ₈ "	12 ³ / ₈ "	14 ¹ / ₈ "	17 ³ / ₈ "	19 ³ / ₈ "	6
			10 ¹ / ₈ "	12 ³ / ₈ "	15	17 ³ / ₈ "	19 ³ / ₈ "	7
			10 ³ / ₈ "	12 ³ / ₈ "	15 ¹ / ₈ "	17 ³ / ₈ "	19 ³ / ₈ "	8
				9 ³ / ₈ "	12 ³ / ₈ "	14 ³ / ₈ "	17 ³ / ₈ "	0
				10 ¹ / ₈ "	12 ³ / ₈ "	15	17 ³ / ₈ "	1
				11	13 ¹ / ₈ "	15 ¹ / ₈ "	18 ¹ / ₈ "	2
				12 ¹ / ₈ "	14 ³ / ₈ "	16 ¹ / ₈ "	19 ¹ / ₈ "	3
				13 ¹ / ₈ "	15 ³ / ₈ "	17 ³ / ₈ "	19 ¹ / ₈ "	4
			14 ¹ / ₈ "	16 ³ / ₈ "	18 ³ / ₈ "	20 ³ / ₈ "	5	
			15 ³ / ₈ "	17	19 ³ / ₈ "	21 ³ / ₈ "	6	
			15 ³ / ₈ "	17 ³ / ₈ "	19 ³ / ₈ "	21 ³ / ₈ "	7	
			15 ¹ / ₂ "	17 ³ / ₈ "	19 ³ / ₈ "	21 ³ / ₈ "	8	

ASIENTO EXCENTRICO EN EL DORSO DE UN CODO DE RADIO LARGO
(TIPO # 3) TUBERIA DE PESO ESTANDAR

LA BASE DEL TUBO SE ALINEA CON EL RADIO INTERIOR DEL CODO

	TAMAÑO DEL CODO						No.
	10"	12"	14"	16"	18"	20"	
Tub. de 8"	12 1/8"	14 3/8"	17 1/2"	20 1/2"	23"	25 1/2"	0
	12 1/2"	15 1/4"	18 1/2"	20 13/16"	23 3/8"	25 1/4"	1
	13 1/8"	16 1/8"	19 3/8"	21 1/4"	24 1/4"	26 3/8"	2
	15 1/8"	17 1/4"	20 3/8"	23 1/4"	25 1/4"	28"	3
	17 1/8"	19 1/8"	22 1/2"	24 1/4"	26 1/4"	29 1/4"	4
	19 1/8"	20 3/8"	23 1/2"	25 1/2"	28 1/8"	30 3/8"	5
	19 3/8"	21 1/4"	24 1/4"	26 3/8"	28 3/4"	31 1/4"	6
	20 1/4"	21 1/2"	24 1/2"	27 1/4"	29 3/8"	31 3/4"	7
Tub. de 10"	20 3/8"	21 13/16"	25 1/4"	27 3/8"	29 1/4"	31 1/2"	8
		14 3/8"	17 1/2"	20 1/2"	23 3/8"	25 3/8"	0
		15 3/8"	18 1/2"	21"	23 1/2"	26"	1
		17"	20 1/4"	22 1/4"	24 13/16"	27 1/4"	2
		19 3/8"	22 1/2"	24 1/2"	26 11/16"	29"	3
		22 1/8"	24 11/16"	26 1/2"	28 1/4"	30 11/16"	4
		24 3/8"	26 1/2"	28 3/8"	30 3/8"	32 3/8"	5
		25"	27 3/8"	29 1/4"	31 1/4"	33 3/8"	6
Tub. de 12"		25 1/2"	28 3/8"	29 1/2"	31 1/4"	33 13/16"	7
		25 1/2"	28 3/4"	29 3/4"	31 3/4"	34"	8
		18"	20 1/2"	23 1/2"	25 3/8"	27 3/8"	0
		18 11/16"	21 1/4"	23 11/16"	26 3/8"	27 3/8"	1
		20 1/8"	23 1/4"	25 1/8"	27 11/16"	29 11/16"	2
		24 3/8"	26"	28"	30 3/8"	33"	3
		28 1/8"	29 3/8"	30 11/16"	32 3/8"	34 3/8"	4
		30 13/16"	31 3/8"	32 3/8"	34 1/4"	36 1/4"	5
Tub. de 14"		32	32 3/8"	33 1/4"	35 3/8"	37 3/8"	6
		32 1/2"	33 3/8"	34 1/2"	36 3/8"	38 3/8"	7
		32 3/8"	33 3/8"	34 11/16"	36 1/2"	38 1/2"	8
		20 1/2"	23 1/4"	25 1/4"	27 1/4"	29 1/4"	0
			21 1/8"	23 3/4"	26 1/4"	28 1/4"	1
			23 3/8"	25 3/8"	28 1/4"	30 1/4"	2
			27 3/8"	29"	31 3/8"	33 3/8"	3
			31 1/8"	32 3/8"	34"	36 3/8"	4
		33 13/16"	34 3/8"	36 1/4"	38 1/4"	5	
		35 1/4"	36 3/8"	37 3/4"	39 3/4"	6	
		35 3/8"	36 3/4"	38 3/8"	40 3/8"	7	
		35 3/4"	36 13/16"	38 1/2"	40 1/2"	8	

ASIENTO EXCENTRICO EN EL DORSO DE UN CODO DE RADIO LARGO A 90°
(TIPO # 3) TUBERIA DE PESO ESTANDAR

LA BASE DEL TUBO SE ALINEA CON EL RADIO INTERIOR DEL CODO

	TAMAÑO DEL CODO				No.
	18"	20"	22"	24"	
Tub. de 16"	23 1/8"	25 1/4"	28 3/8"	30 3/8"	0
	23 13/16"	26 1/4"	28 1/2"	31 1/8"	1
	26 11/16"	28 13/16"	31 1/4"	33 3/8"	2
	31"	32 13/16"	34 1/4"	36 3/4"	3
	35 1/2"	36 3/8"	38 3/8"	40"	4
	38 13/16"	39 1/2"	40 13/16"	42 1/2"	5
	40 3/8"	41"	42 3/8"	44"	6
	41"	41 3/8"	43"	44 13/16"	7
Tub. de 18"	41 1/4"	41 13/16"	43 3/8"	44 13/16"	8
		25 3/8"	28 1/2"	30 3/8"	0
		26 3/8"	29 1/4"	31 1/8"	1
		29 3/8"	32"	34 1/4"	2
		34 3/8"	36 3/8"	38 3/8"	3
		40 3/8"	41"	42 3/4"	4
		44"	44 3/8"	45 3/8"	5
		45 3/8"	46"	47 1/2"	6
Tub. de 20"		46 3/8"	46 11/16"	47 3/4"	7
		46 3/8"	46 1/2"	48 1/2"	8
			28 1/2"	30 3/8"	0
			29 3/8"	31 1/4"	1
			32 1/8"	35 1/4"	2
			38 1/2"	40 1/8"	3
			44 13/16"	45 3/8"	4
			49 3/8"	49 3/8"	5
Tub. de 22"			50 3/8"	51"	6
			51 1/8"	51 1/2"	7
			51 3/8"	52"	8
				30 3/8"	0
				32"	1
				35 13/16"	2
				42 3/8"	3
				49 3/8"	4
			54 1/4"	5	
			56 3/8"	6	
			56 1/2"	7	
			57 1/4"	8	

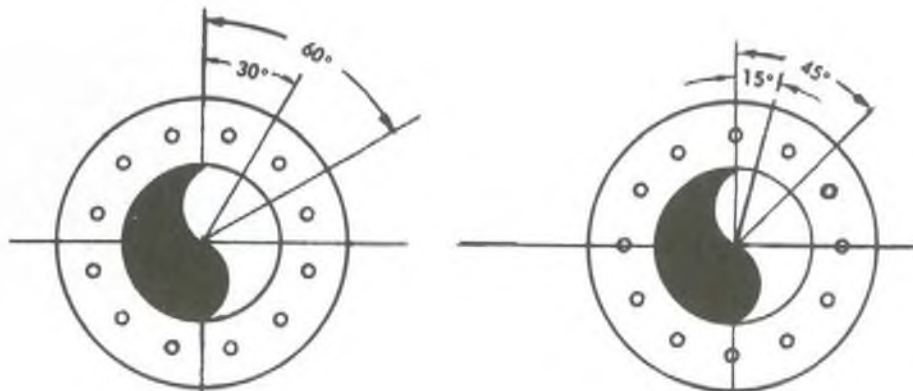

ANGULOS ENTRE LOS AGUJEROS PARA TORNILLOS EN LAS BRIDAS

AGUJEROS DE TORNILLOS A CADA LADO DE LA L/C	AGUJEROS DE TORNILLOS EN LA L/C
4 AGUJEROS A 90°	4 AGUJEROS A 45°
8 AGUJEROS A 45°	8 AGUJEROS A 22½°*
12 AGUJEROS A 30°	12 AGUJEROS A 15° - 45°
16 AGUJEROS A 22½° - 45°	16 AGUJEROS A 11¼° - 33¾°
20 AGUJEROS A 18° - 36°	20 AGUJEROS A 9° - 27° - 45°
24 AGUJEROS A 15° - 30° - 45°	

TRAZADO DE PLANTILLAS DE LA TUBERÍA UTILIZANDO LOS VALORES DE LAS ORDENADAS QUE APARECEN EN LAS TABLAS DEL PRESENTE LIBRO

1. Se usará un pedazo de papel de dibujo o de un material más fuerte, que tenga un ancho mayor que la circunferencia de la tubería.

La longitud debe ser igual a la mayor dimensión de la ordenada más 2" o más para la dimensión "A" que aparece en las figuras. La longitud de las plantillas para los asientos en codos constituye una excepción y debe ser igual a la distancia del extremo al centro de 2 codos de R.L., como se muestra.

2. Se ajusta el papel alrededor de la tubería, y se corta de tal manera que los extremos del mismo apenas se toquen. Asegúrese que esté en ángulo recto con la tubería.
3. Trácese la línea envolvente o de referencia y márchense las ordenadas en octavos o dieciseisavos.

Los valores de estas líneas de ordenadas se toman de las tablas del libro. Trácese la curva de plantilla teniendo cuidado de que estén en contacto en todo momento tres o más puntos u ordenadas. Se usa una curva francesa o una curva irregular para efectuar el trazado, de modo que se tendrá una curva suave para mayor exactitud. También se logra mayor exactitud con líneas de ordenadas en dieciseisavos que con líneas en octavos.

PLANTILLA PARA CORTES ANGULARES EN OCTAVOS

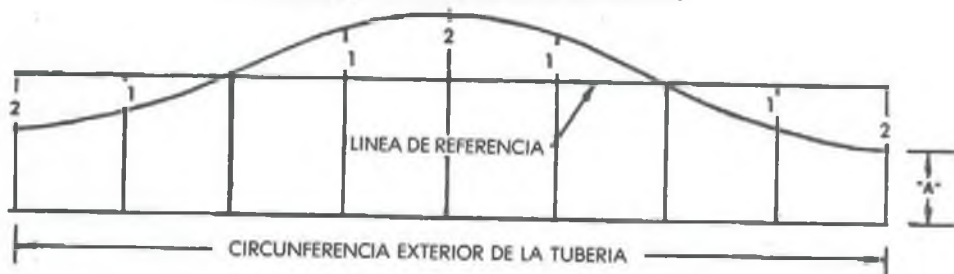

54

PLANTILLA PARA CORTES ANGULARES EN DIECISEISAVOS

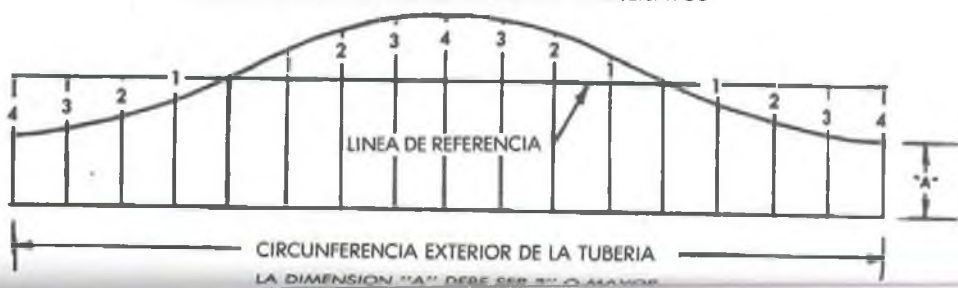

PLANTILLA DE UN RAMAL PARA EL ASIENTO SOBRE UNA TE

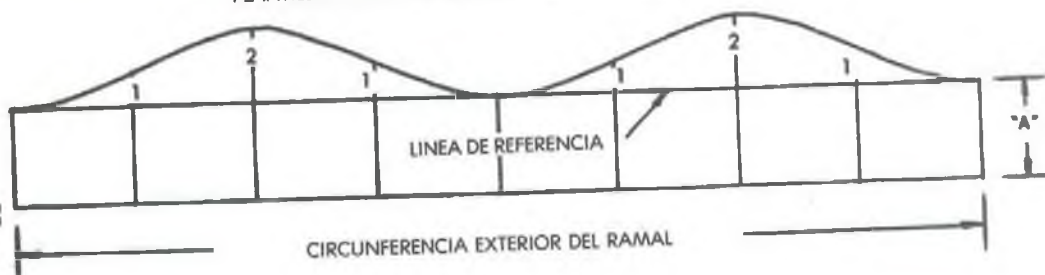

55

LA DIMENSION "A" DEBE SER 2" O MAYOR
 CUANDO SE REALICE EL CORTE, MANTENGASE LA PUNTA DE CORTE DIRIGIDA
 EN TODO MOMENTO HACIA EL CENTRO DE LA TUBERIA.

PLANTILLA DE UN RAMAL PARA TES EXCENTRICAS A 90°

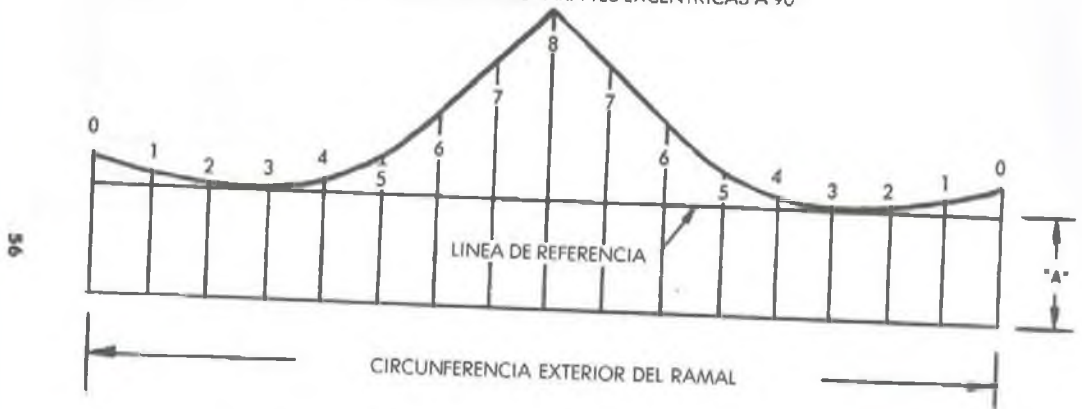

LA DIMENSION "A" DEBE SER 2" O MAYOR
AL REALIZAR EL CORTE, MANTENGASE EN TODO MOMENTO LA PUNTA DE CORTE
DIRIGIDA AL CENTRO DE LA TUBERIA.

PLANTILLA PARA UN RAMAL PARA DERIVACIONES



LA DIMENSION "A" DEBE SER DE 2" O MAYOR
AL REALIZAR EL CORTE, MANTENGASE EN TODO MOMENTO LA PUNTA DE CORTE
DIRIGIDA HACIA EL CENTRO DE LA TUBERIA

PLANTILLA DE UN RAMAL PARA EL ASIENTO EN EL DORSO DE
CODO DE RADIO LARGO A 90°

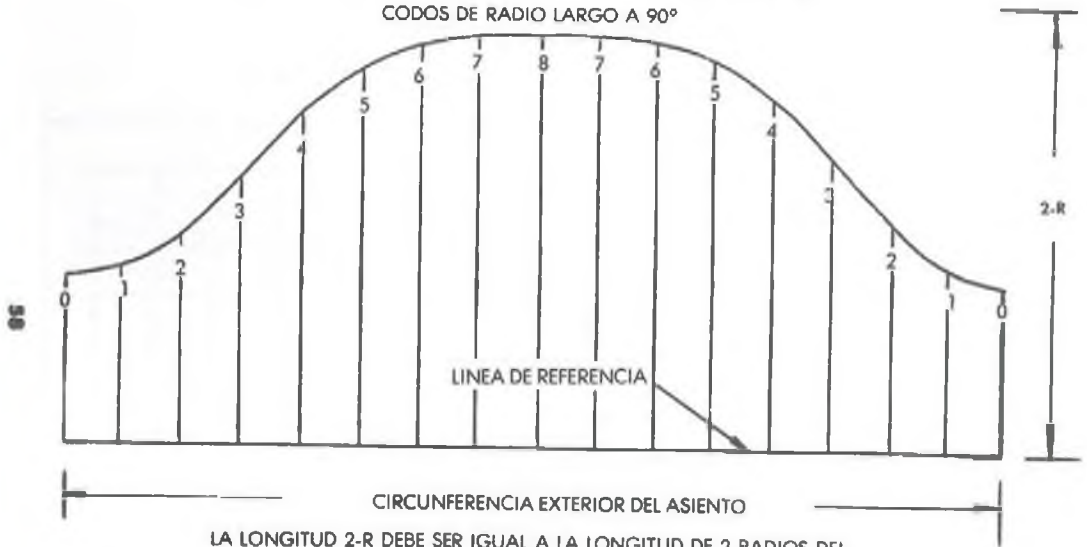

LA LONGITUD 2-R DEBE SER IGUAL A LA LONGITUD DE 2 RADIOS DEL
CODO

AL REALIZAR EL CORTE, MANTENGASE EN TODO MOMENTO LA PUNTA DE CORTE
DIRIGIDA AL CENTRO DE LA TUBERIA.



**CASQUETE CASCARA DE
NARANJA SEMIESFERICO**

1. Trácese la línea basal en la plantilla
2. Márquense las dimensiones "L" y $\frac{1}{3} L$
3. Trácese las dimensiones "A" para el número de segmentos
4. Trácese las líneas de centro entre cada segmento
5. Márquense las dimensiones "B" y "C"
6. Trácese las líneas para conectar los puntos "A", "B" y "C"

**TRAZADO DE LA PLANTILLA PARA UN CASQUETE
SEMIESFERICO TIPO CASCARA DE NARANJA**

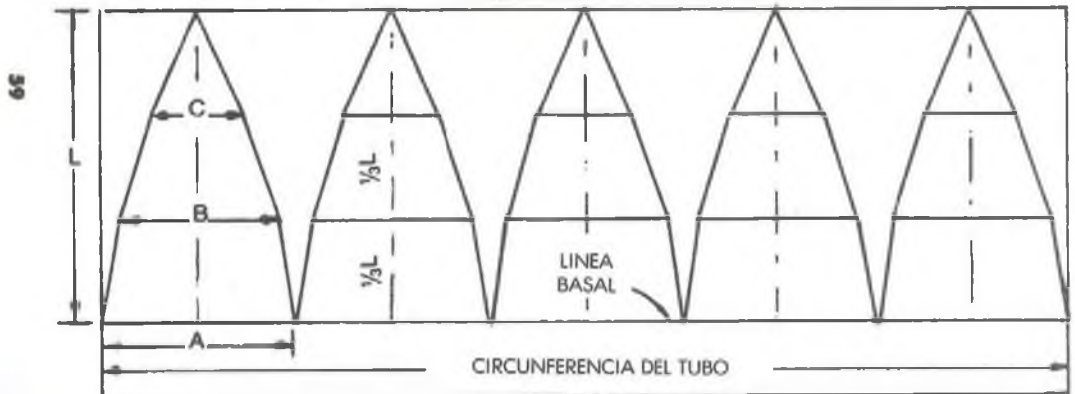

CASQUETE CASCARA DE NARANJA SEMIESFERICO (Pulgadas)

Tamaño del tubo	Núm. de segmentos	A	B	C	L	$\frac{1}{3}L$
2	5	$1\frac{1}{2}$	$1\frac{5}{16}$	$\frac{3}{4}$	$1\frac{7}{8}$	$\frac{5}{8}$
$2\frac{1}{2}$	5	$1\frac{13}{16}$	$1\frac{9}{16}$	$\frac{7}{8}$	$2\frac{1}{4}$	$\frac{3}{4}$
3	5	$2\frac{3}{16}$	$1\frac{15}{16}$	$1\frac{3}{32}$	$2\frac{3}{4}$	$1\frac{5}{16}$
$3\frac{1}{2}$	5	$2\frac{1}{2}$	$2\frac{3}{16}$	$1\frac{1}{4}$	$3\frac{3}{16}$	$1\frac{1}{16}$
4	5	$2\frac{13}{16}$	$2\frac{15}{32}$	$1\frac{7}{16}$	$3\frac{9}{16}$	$1\frac{3}{16}$
5	5	$3\frac{1}{2}$	$3\frac{1}{16}$	$1\frac{3}{4}$	$4\frac{3}{8}$	$1\frac{7}{16}$
6	5	$4\frac{3}{16}$	$3\frac{5}{8}$	$2\frac{1}{16}$	$5\frac{1}{4}$	$1\frac{3}{4}$
8	6	$4\frac{1}{2}$	$3\frac{15}{16}$	$2\frac{1}{4}$	$6\frac{3}{4}$	$2\frac{1}{4}$
10	7	$4\frac{13}{16}$	$4\frac{7}{32}$	$2\frac{13}{32}$	$8\frac{7}{16}$	$2\frac{13}{16}$
12	8	5	$4\frac{3}{8}$	$2\frac{1}{2}$	10	$3\frac{5}{16}$

FORMULAS UTILIZADAS

- A** = CIRCUNFERENCIA DEL DIAMETRO EXTERIOR DEL TUBO
DIVIDIDA ENTRE EL NUMERO DE SEGMENTOS
- B** = DIMENSION "A" \times 0.875
- C** = DIMENSION "A" \times 0.5
- L** = CIRCUNFERENCIA DEL DIAMETRO EXTERIOR DEL TUBO
DIVIDIDA ENTRE 4
NUMERO DE SEGMENTOS = CIRCUNFERENCIA DEL DIAMETRO
EXTERIOR DEL TUBO DIVIDIDA ENTRE 5
EL MINIMO SERA 5 SEGMENTOS
USESE UN CORTE RADIAL.

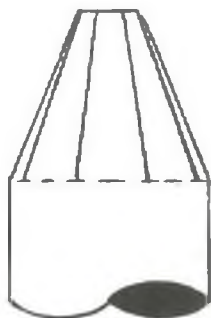
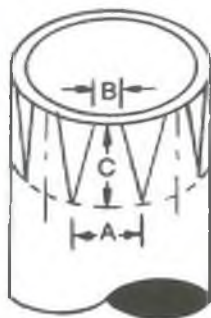

TRAZADO DE UN REDUCTOR CONCENTRICO

"A" = Circunferencia del tubo mayor dividida entre el número de segmentos.

"B" = Circunferencia del tubo menor dividida entre el número de segmentos.

"C" = Diferencia entre los diámetros exteriores de las tuberías $\times 1.3$.

"N" = Número de segmentos = diferencia entre los diámetros exteriores de las tuberías $\times 1.33$.
Mínimo 4 segmentos.

1. Trácese la línea envolvente en el tubo igual a la distancia "C".
2. Trácese sobre esta línea las divisiones según la dimensión "A".
3. Trácese líneas sobre la tubería a la mitad de cada dimensión "A".
4. Márquense las dimensiones "B" sobre estos líneas en el extremo del tubo, con $\frac{1}{2}$ a cada lado de la línea.
5. Trácese líneas para conectar los puntos "B" con los puntos en la línea envolvente.
6. Córtese con el soplete las secciones entre los segmentos, utilizando un corte radial, después se biselan los segmentos.

TRAZADO DE LA PLANTILLA PARA UN REDUCTOR CONCENTRICO

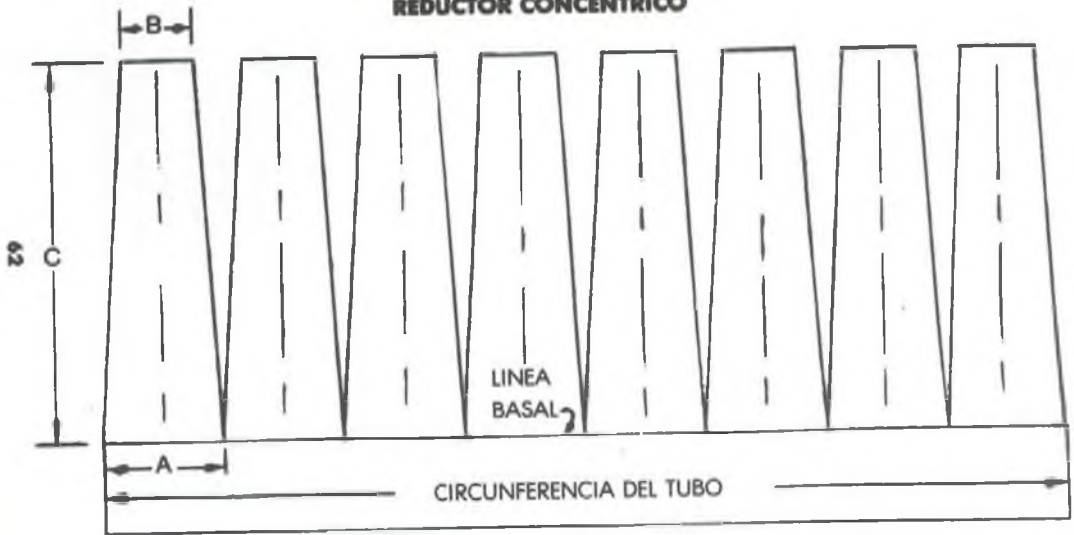

REDUCTORES CONCENTRICOS (Pulgadas)

Tamaño del tubo	No. de segtos.	A	B	C	Tamaño del tubo	No. de segtos.	A	B	C
2 x 1½	5	1½	1⅜	⅝	4 x 3½	5	2 ¹³ / ₁₆	2½	1 ¹ / ₁₆
2 x 1¼	5	1½	1⅜	15 ¹ / ₁₆	4 x 3	5	2 ¹³ / ₁₆	2⅜	15 ¹ / ₁₆
2 x 1	5	1½	1⅜	1⅝	4 x 2½	5	2 ¹³ / ₁₆	1 ¹³ / ₁₆	2⅝
2½ x 2	5	1 ¹³ / ₁₆	1½	1 ¹ / ₁₆	4 x 2	5	2 ¹³ / ₁₆	1½	2¾
2½ x 1½	5	1 ¹³ / ₁₆	1⅜	1¼	4 x 1½	5	2 ¹³ / ₁₆	1⅜	3⅝
2½ x 1¼	5	1 ¹³ / ₁₆	1⅜	19 ¹ / ₁₆	4 x 1¼	5	2 ¹³ / ₁₆	1⅜	3 ¹ / ₁₆
2½ x 1	5	1 ¹³ / ₁₆	1⅜	2	4 x 1	5	2 ¹³ / ₁₆	1⅜	4⅝
3 x 2½	5	2⅜	1 ¹³ / ₁₆	13 ¹ / ₁₆	5 x 4	5	3½	2 ¹³ / ₁₆	1⅝
3 x 2	5	2⅜	1½	1½	5 x 3½	5	3½	2½	2 ¹ / ₁₆
3 x 1½	5	2⅜	1⅜	2⅝	5 x 3	5	3½	2⅜	2 ¹ / ₁₆
3 x 1¼	5	2⅜	1⅜	2⅝	5 x 2½	5	3½	1 ¹³ / ₁₆	3½
3 x 1	5	2⅜	1⅜	2⅝	5 x 2	5	3½	1½	4⅝
3½ x 3	5	2½	2⅜	1 ¹ / ₁₆	5 x 1½	5	3½	1⅜	4¾
3½ x 2½	5	2½	1 ¹³ / ₁₆	1½	5 x 1¼	5	3½	1⅜	5 ¹ / ₁₆
3½ x 2	5	2½	1½	2⅝	5 x 1	5	3½	1⅜	5½
3½ x 1½	5	2½	1⅜	2¾					
3½ x 1¼	5	2½	1⅜	3 ¹ / ₁₆					
3½ x 1	5	2½	1⅜	3½					

REDUCTORES CONCÉNTRICOS (Pulgadas)

Tamaño del tubo	No. de segtos.	A	B	C	Tamaño del tubo	No. de segtos.	A	B	C
6 x 5	5	4 ⁵ / ₃₂	3 ¹ / ₂	1 ¹ / ₂	10 x 8	7	4 ¹³ / ₁₆	3 ⁷ / ₈	2 ³ / ₄
6 x 4	5	4 ⁷ / ₃₂	2 ¹³ / ₁₆	2 ³ / ₄	10 x 6	7	4 ¹³ / ₁₆	3	5 ³ / ₈
6 x 3 ¹ / ₂	5	4 ⁵ / ₃₂	2 ¹ / ₂	3 ⁷ / ₈	10 x 5	7	4 ¹³ / ₁₆	2 ¹ / ₂	6 ³ / ₄
6 x 3	5	4 ⁵ / ₃₂	2 ⁹ / ₁₆	4 ¹ / ₈	10 x 4	8	4 ⁷ / ₃₂	1 ³ / ₄	8 ¹ / ₈
6 x 2 ¹ / ₂	5	4 ⁵ / ₃₂	1 ¹³ / ₁₆	4 ⁷ / ₈	10 x 3 ¹ / ₂	9	3 ³ / ₄	1 ³ / ₈	8 ³ / ₄
6 x 2	6	3 ¹⁵ / ₃₂	1 ¹ / ₄	5 ¹ / ₂	10 x 3	10	3 ³ / ₈	1 ¹ / ₈	9 ⁷ / ₁₆
6 x 1 ¹ / ₂	6	3 ¹⁵ / ₃₂	1	6 ¹ / ₈	10 x 2 ¹ / ₂	11	3 ¹ / ₁₆	1 ⁹ / ₁₆	10 ¹ / ₄
8 x 6	6	4 ¹ / ₂	3 ¹⁵ / ₃₂	2 ⁵ / ₈	12 x 10	8	5	4 ⁷ / ₃₂	2 ⁵ / ₈
8 x 5	6	4 ¹ / ₂	2 ²⁹ / ₃₂	4	12 x 8	10	4	2 ²³ / ₃₂	5 ³ / ₈
8 x 4	6	4 ¹ / ₂	2 ¹¹ / ₃₂	5 ³ / ₈	12 x 6	10	4	2 ⁹ / ₃₂	8
8 x 3 ¹ / ₂	6	4 ¹ / ₂	2 ³ / ₃₂	6	12 x 5	10	4	1 ³ / ₄	9 ³ / ₈
8 x 3	7	3 ⁷ / ₈	1 ⁹ / ₁₆	6 ¹ / ₁₆	12 x 4	11	3 ²¹ / ₃₂	1 ⁹ / ₃₂	10 ¹ / ₄
8 x 2 ¹ / ₂	8	3 ³ / ₈	1 ¹ / ₈	7 ¹ / ₂	12 x 3 ¹ / ₂	12	3 ¹¹ / ₃₂	1 ¹ / ₁₆	11 ³ / ₈
8 x 2	8	3 ³ / ₈	1 ⁹ / ₁₆	8 ¹ / ₈	12 x 3	12	3 ¹¹ / ₃₂	1 ⁹ / ₁₆	12

TRAZADO DE LA PLANTILLA PARA UN REDUCTOR EXCÉNTRICO

El uso de una plantilla para un reductor excéntrico resulta más simple y más exacto que marcar el tubo. Se usará chapa metálica o material de juntas de aproximadamente 1/32" de grosor. La longitud del material deberá ser ligeramente mayor que la circunferencia de la tubería. El ancho deberá ser aproximadamente 4" mayor que la dimensión "E". Compruébese que el material esté exactamente a escuadra. Ajustese el material alrededor de la circunferencia de la tubería y márquese y córtese de modo que los extremos del material apenas se toquen. Deben seguirse los pasos indicados a continuación.

1. Trácese la línea basal en la plantilla, 3" arriba del borde.
2. Trácese la línea de centro en la plantilla, en el centro exacto del segmento 1.
3. En la línea de centro de la línea basal, marcar 1/8 de la circunferencia del tubo menor a cada lado de la plantilla.

SE INICIAN ESTOS PASOS EN EL LADO IZQUIERDO DE LA PLANTILLA Y SE REPITE EN EL LADO DERECHO

1. Márquese la dimensión "F" en el borde izquierdo de la plantilla, a partir de la línea basal.
2. Márquese en este punto la dimensión 1 1/2 A, para el segmento 4.
3. Márquese la dimensión "B".
4. Márquese la dimensión "A" para el segmento 3.
5. Márquese la dimensión "C".
6. Márquese la dimensión "A" para el segmento 2.
7. En la línea de centro, márquese 1/2 de la dimensión "A" a cada lado del segmento 1.
8. Trácese líneas en cada segmento hasta los puntos marcados en la línea basal.

Usese un corte radial y bisélese cada segmento una vez efectuado el corte. Caliéntese y désele forma primero al segmento inferior; después se calientan los abojos restantes, de modo que se puedan conformar hacia abajo y hacia adentro. Estos reductores excéntricos se pueden cortar para tuberías mayores, según se requiera.

TRAZADO DE LA PLANTILLA PARA REDUCTORES EXCENTRICOS

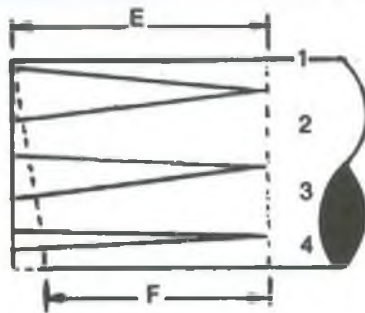
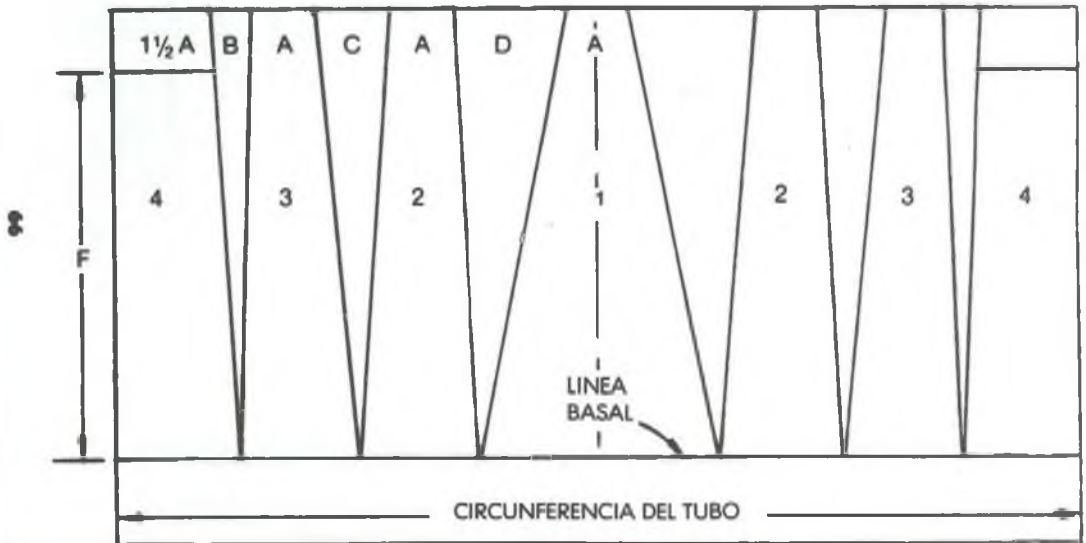

REDUCTOR EXCENTRICO

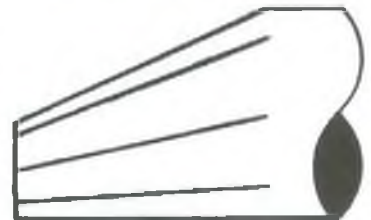

FORMULAS

- "A" = $\frac{1}{8}$ de la circunferencia de la tubería menor
- "B" = Diferencia entre las circunferencias exteriores $\times 0.0833$
- "C" = Diferencia entre las circunferencias exteriores $\times 0.1666$
- "D" = Diferencia entre las circunferencias exteriores $\times 0.25$
- "E" = $1\frac{1}{2} \times$ D.E. de la tubería mayor
- "F" = Dimensión "E" $\times 0.866$

Usese un corte radial

REDUCTORES EXCENTRICOS (Pulgadas)

3 x 2		3 1/2 x 2	
A =	15/16	A =	15/16
B =	5/16	B =	7/16
C =	9/16	C =	7/8
D =	7/8	D =	1 1/4
E =	5 1/4	E =	6
F =	4 9/16	F =	5 3/16
1 1/2 A =	1 13/32	1 1/2 A =	1 13/32
Circunferencia de un tubo de 3" = 11"		Circ. de un tubo de 3 1/2" = 12 7/16"	
1/8 de la circunferencia = 1 3/8"		1/8 de la circunferencia = 1 9/16"	

REDUCTORES EXCENTRICOS (Pulgadas)

4 x 2		5 x 2 1/2	
A =	15/16	A =	1 1/8
B =	9/16	B =	1 1/16
C =	1 1/8	C =	1 3/8
D =	1 11/16	D =	2 1/8
E =	6 3/4	E =	8 3/8
F =	5 7/8	F =	7 1/4
1 1/2 A =	1 13/32	1 1/2 A =	1 11/16
Circunferenc. de un tubo de 4" = 14 1/8"		Circunfer. de un tubo de 5" = 17 1/2"	
1/8 de la circunferencia = 1 3/4"		1/8 de la circunferencia = 2 1/16"	

REDUCTORES EXCENTRICOS (Pulgadas)

6 x 3		8 x 4	
A =	1 3/8	A =	1 3/4
B =	1 3/16	B =	1 1/16
C =	1 5/8	C =	2 1/8
D =	2 7/16	D =	3 1/4
E =	10	E =	13
F =	8 11/16	F =	11 1/4
1 1/2 A =	2 1/16	1 1/2 A =	2 5/8
Circunf. de un tubo de 6" = 20 13/16"		Circunf. de un tubo de 8" = 27 1/8"	
1/8 de la circunferencia = 2 5/8"		1/8 de la circunferencia = 3 3/8"	

REDUCTORES EXCENTRICOS (Pulgadas)

10 x 6		12 x 6	
A =	2 5/8	A =	2 5/8
B =	1 1/16	B =	1 5/8
C =	2 1/8	C =	3 3/16
D =	3 1/4	D =	4 13/16
E =	16 1/8	E =	19 1/8
F =	14	F =	16 9/16
1 1/2 A =	3 15/16	1 1/2 A =	3 15/16
Circunf. de un tubo de 10" = 33 3/4"		Circunf. de un tubo de 12" = 40 1/16"	
1/8 de la circunferencia = 4 7/32"		1/8 de la circunferencia = 5"	

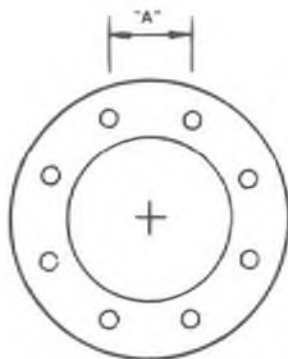

TRAZADO DE LOS AGUJEROS EN BRIDAS

FORMULA: Para encontrar la dimensión "A", multiplíquese el diámetro del círculo basal de tornillos por el SENO de la mitad del ángulo entre agujeros. Se muestra como ejemplo 45° entre 2 = $22\frac{1}{2}^\circ$.

NO. DE AGUJEROS	DIAM. X DEL CIRCULO BASAL DE TORNILLOS	NO. DE AGUJEROS	DIAM. X DEL CIRCULO BASAL DE TORNILLOS
4	.7071	20	.1564
6	.500	24	.1305
8	.3827	28	.1120
12	.2588	32	.0980
16	.1951	36	.0871

TRAZADO DE LAS LINEAS DE ORDENADAS Y SUS LONGITUDES PARA UNA TOBERA CONCENTRICA O TANGENCIAL

Márquese en un compás de puntas un radio que sea igual al D.I. de la tobera, cuando se ha de ajustar a la pared exterior del recipiente. Ajustese el compás de puntas para el D.E. de la tobera cuando se vaya a ajustar a la pared interior del recipiente.

Con el compás de puntas correctamente ajustado, grabar un arco de 180° sobre un pedazo de material de juntas o chapa metálica y trácese una línea a través de este semicírculo.

Trácense las líneas 0 y 4 en toda la longitud de este material.

Usese el compás de puntas para dividir cada semicírculo en 4 secciones iguales de $22\frac{1}{2}^\circ$. Trácense, en dichos puntos, las líneas 1, 2 y 3, como antes.

En una mesa u otra superficie grábese un arco con un radio igual al D.E. o al D.I. de la pared del recipiente donde se ha de ajustar la tobera.

Colóquese el material marcado sobre este arco, en la posición exacta que se desee, asegurándose que esté a escuadra con el recipiente. Si se trata de una tobera de tipo tangencial, habrá que asegurarse que el D.E. de la tobera no vaya más allá de la pared exterior del recipiente. Manteniendo el material en posición y en el punto alto de la pared del recipiente, trácese sobre el material una línea envolvente o de referencia en el material. Hay veces en que la línea 0 tiene una cierta longitud, por lo que se debe cuidar que se trate del punto más alto.

Grabar el radio del recipiente sobre el material. Se tienen ahora las longitudes de las ordenadas sobre el material.

El trazado de la plantilla para cualesquiera de estos tipos aparece en la sección de trazado de plantillas.

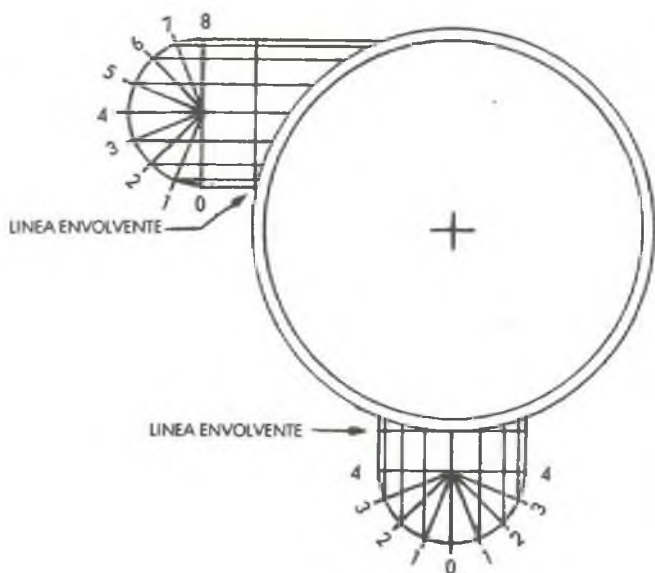

LONGITUD DE LAS LINEAS DE ORDENADAS

Se recomienda espaciar estas líneas de ordenadas con el compás de punta; no obstante, también se pueden calcular dichos espaciamientos. Los números de las líneas que aparecen a continuación se refieren al tipo concéntrico.

Línea 4 = $\frac{1}{2}$ del D.I. o el D.E. del tubo o tobera

Línea 1 = Dimensión 4 \times 0.3827

Línea 2 = Dimensión 4 \times 0.707

Línea 3 = Dimensión 4 \times 0.9239

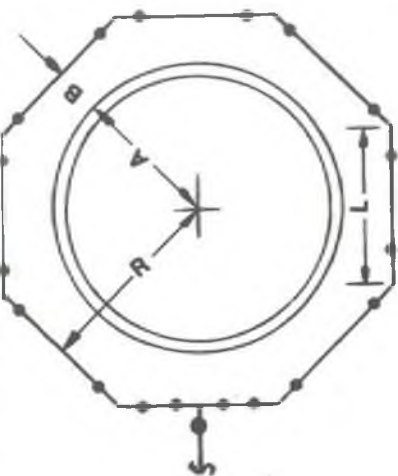

TUBERIA DEL SERPENTIN FUERA DEL TANQUE

FORMULA PARA LA DIMENSION "L"
 $"R" \times 2 \times \text{TANGENTE de la mitad}$
 del ángulo del sector

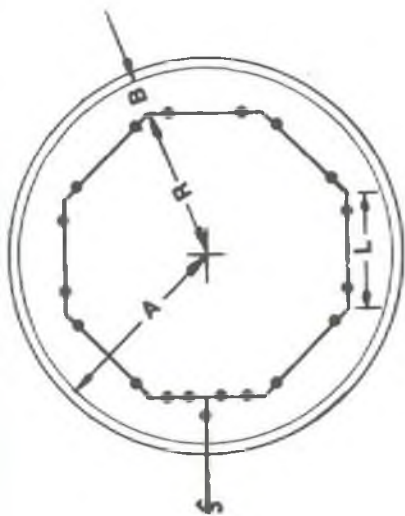

TUBERIA DEL SERPENTIN DENTRO DEL TANQUE

FORMULA PARA LA DIMENSION "L"
 $"R" \times 2 \times \text{SENO de la mitad}$
 del ángulo del sector

SERPENTINES EN TANQUES

SERPENTIN DENTRO DEL TANQUE			SERPENTIN FUERA DEL TANQUE		
A = Radio interior del tanque B = Claro dentro del tanque R = Radio del serpentín L = Longitud centro a centro			A = Radio exterior del tanque B = Claro fuera del tanque R = Radio del serpentín L = Longitud centro a centro		
Angulo del accesorio	No. de tubos por serpentín	Seno	Angulo del accesorio	No. de tubos por serpentín	Tangente
90°	4	.707	90°	4	1.000
60°	6	.500	60°	6	.577
45°	8	.3827	45°	8	.414
30°	12	.2588	30°	12	.2679
22½°	16	.195	22½°	16	.1989
11¼°	32	.098	11¼°	32	.0985

74

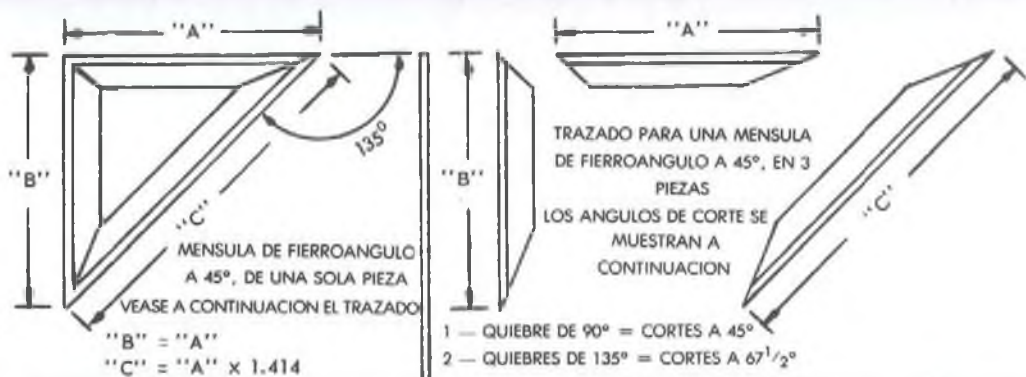

75

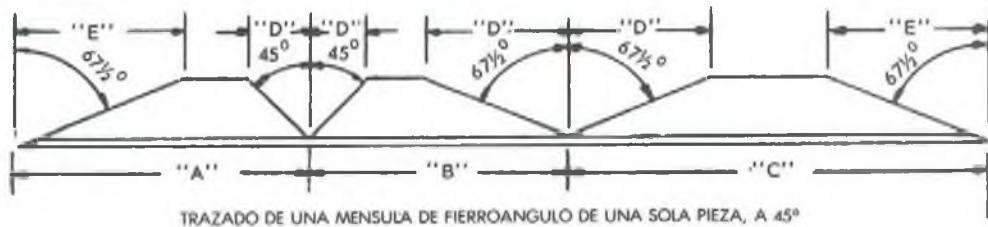

DIMENSIONES PARA EL TRAZADO DE LOS CORTES ANGULARES EN LOS FIERROANGULOS

Corte a 11 1/2° para un quiebre de 22 1/2° = ancho X 0.1997		Corte a 30° para un quiebre de 60° ancho X 0.5773	
Tamaño	"D", una pieza	"E", dos piezas	"D", una pieza
1/8" X 1"	3/16"	3/16"	1/2"
3/4" X 1 1/2"	1/4"	9/16"	3/4"
1/4" X 2	3/16"	3/8"	1
3/8" X 2 1/2"	7/16"	1/2"	1 1/4"
3/8" X 3	1/2"	9/16"	1 1/2"
3/8" X 4	3/4"	1 1/16"	2 1/16"
Corte a 15° para un quiebre de 30° = ancho X 0.2679			
Tamaño	"D", una pieza	"E", dos piezas	"D", una pieza
1/8" X 1"	1/4"	1/4"	1/2"
1/4" X 1 1/2"	5/16"	3/8"	1 1/4"
1/4" X 2	7/16"	1/2"	1 3/4"
3/8" X 2 1/2"	9/16"	1 1/16"	2 1/8"
3/8" X 3	1 1/16"	1 3/16"	2 3/8"
3/8" X 4	1	1 3/16"	3 3/8"
Corte a 22 1/2° para un quiebre de 45° = ancho X 0.414			
Tamaño	"D", una pieza	"E", dos piezas	"D", una pieza
1/8" X 1"	3/8"	7/16"	2 1/8"
1/4" X 1 1/2"	1/2"	3/4"	3
1/4" X 2	3/4"	1 3/16"	4 1/4"
3/8" X 2 1/2"	3/4"	1	5 1/8"
3/8" X 3	1 1/16"	1 1/4"	6 1/16"
3/8" X 4	1 1/2"	1 3/4"	8 3/4"
Corte a 67 1/2° para un quiebre de 135° = ancho X 2.1414			
Tamaño	"D", una pieza	"E", dos piezas	"E", dos piezas
1/8" X 1"	1/2"	1/2"	2 1/16"
1/4" X 1 1/2"	3/4"	3/4"	3 3/8"
1/4" X 2	1	4 1/4"	4 13/16"
3/8" X 2 1/2"	1 1/8"	5 1/8"	6
3/8" X 3	1 1/4"	6 1/16"	7 1/4"
3/8" X 4	1 3/4"	8 3/4"	9 3/8"

DESPLAZAMIENTOS ESPECIALES (DIBUJO # 1)

Desplazamientos especiales cuando se conoce el ángulo de elevación y el desplazamiento.

FORMULA: El coseno del ángulo de elevación, multiplicado por el coseno del ángulo de desplazamiento es igual al coseno del ángulo del codo.

Encuéntrese el grado del codo inferior:

El coseno del ángulo de elevación de 45° es 0.707; este valor multiplicado por 0.866, el coseno del ángulo de desplazamiento de 30° , es igual a 0.6123, el coseno del ángulo del codo. En las tablas trigonométricas se ve que 0.6123 es el coseno de $52^\circ 14'$. Este es el ángulo del codo inferior.

El codo superior tiene un desplazamiento horizontal de 60° y es el complemento de desplazamiento del codo inferior. El ángulo de elevación es siempre el mismo para ambos codos.

Encuéntrese el ángulo del codo superior:

El coseno del ángulo de elevación de 45° es 0.707; este valor multiplicado por 0.500, el coseno de desplazamiento de 60° , es igual a 0.3535, el coseno del ángulo del codo. En las tablas trigonométricas se ve que 0.3535 es el coseno de $69^\circ 18'$. Este es el ángulo del codo superior.

Encuéntrese la longitud de los lados de los 2 triángulos rectángulos:

Se usa el lado de 24" altura correspondiente al valor de 24" para calcular los lados que faltan. Véase para el método, las páginas 9 y 10 del libro, bajo el epígrafe ANGULO CONOCIDO. Nótese que el lado de proyección de este ángulo es también el lado de carrera del ángulo de 30° .

El lado de (carrera) del ángulo de elevación es la verdadera magnitud de la longitud centro a centro del desplazamiento.

Encuéntrese la longitud requerida de corte de la tubería:

Refiérase a las páginas 7 y 8 del libro y a la figura 8 para el método de cálculo de la longitud extremo a centro de los dos codos mencionados, ya que éstos deben restarse de la distancia centro a centro del desplazamiento para obtener la longitud de corte requerida.

TODOS LOS DESPLAZAMIENTOS SIMILARES SE PUEDEN CALCULAR UTILIZANDO ESTE PROCEDIMIENTO.

DESPLAZAMIENTOS ESPECIALES
DIBUJO # 1

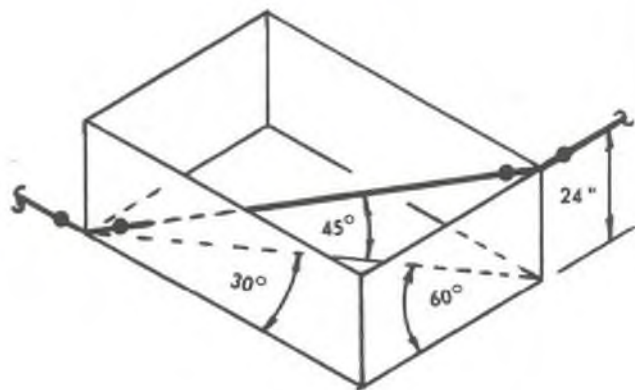

DESPLAZAMIENTOS ESPECIALES (DIBUJO # 2)

Cálculo de desplazamientos especiales cuando no se conocen los ángulos.

FORMULA: El coseno del ángulo de elevación multiplicado por el coseno del ángulo de desplazamiento es igual al coseno del ángulo del codo.

En este ejemplo, será preciso utilizar las dimensiones de los dos triángulos rectángulos para calcular los ángulos de elevación y de desplazamiento. Se hará referencia a las páginas 9 y 10 del libro bajo el encabezado PARA HALLAR EL ANGULO. Se verá que el ángulo de elevación es de 30° y el ángulo de desplazamiento horizontal es de $22^\circ-30'$. Para la longitud de los lados se usará la tabla ANGULO CONOCIDO.

El uso del coseno multiplicado por el coseno equivale a la fórmula de los cosenos:

El ángulo del codo inferior es de $36^\circ-52'$

El ángulo del codo superior es de 60°

Nótase que el codo superior es el complemento de la elevación del codo inferior. $90^\circ-30^\circ = 60^\circ$ (el ángulo del codo superior). El lado de proyección del ángulo de 30° es también el lado de recorrido del ángulo de $22^\circ-30'$.

El lado de recorrido del ángulo de elevación es la verdadera magnitud del desplazamiento.

Encuéntrese la longitud de corte de la tubería requerida:

Hágase referencia a las páginas 7 y 8 y a la figura 8, para el método de cálculo de los centros de los 2 codos mencionados, ya que será preciso restarlos para obtener la longitud de corte requerida.

Nótase que cualesquiera 2 cosenos utilizados requerirán el mismo ángulo de codo, no importa cuál sea su relación.

DESPLAZAMIENTOS ESPECIALES
DIBUJO # 2

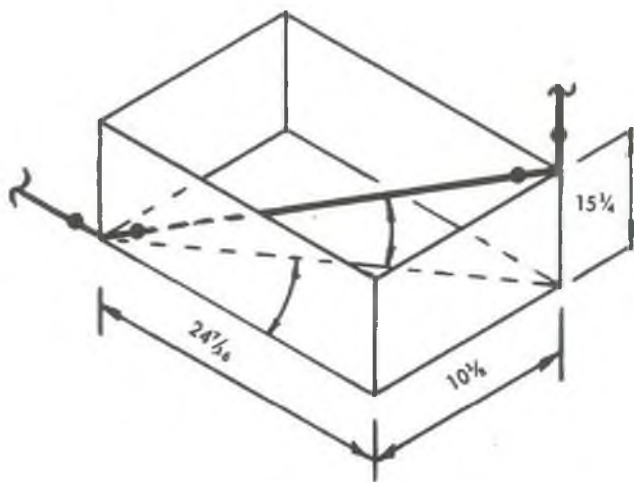

A fin de simplificar la fabricación, manejo e instalación de todos los tipos especiales de desplazamientos, se recomienda que en lo posible, se instalen juntas de traslope, constituidas por bridas, en cada extremo y entre los dos codos. De este modo, el fabricante puede hacer caso omiso del desplazamiento complejo y de tener que hacer coincidir los barrenos de los pernos.

En la página opuesta se muestran 6 tipos diversos de desplazamientos especiales con el ángulo de codo necesario para las partes inferior y superior.

La tabla que aparece a continuación muestra algunas combinaciones estándar de ángulos, con sus cosenos multiplicados para dar el ángulo de codo requerido. Nótese que los resultados serán los mismos, sin importar cuál sea el ángulo de elevación y desplazamiento.

$22\frac{1}{2}^{\circ} = 31^{\circ}-24'$ $22\frac{1}{2}^{\circ}$	$30^{\circ} = 41^{\circ}-24'$ 30°	$45^{\circ} = 60^{\circ}$ 45°
$22\frac{1}{2}^{\circ} = 36^{\circ}-52'$ 30°	$30^{\circ} = 52^{\circ}-14'$ 45°	$45^{\circ} = 69^{\circ}-18'$ 60°
$22\frac{1}{2}^{\circ} = 49^{\circ}-13'$ 45°	$30^{\circ} = 64^{\circ}-20'$ 60°	$45^{\circ} = 74^{\circ}-18'$ $67\frac{1}{2}^{\circ}$
$22\frac{1}{2}^{\circ} = 62^{\circ}-29'$ 60°	$30^{\circ} = 70^{\circ}-39'$ $67\frac{1}{2}^{\circ}$	
$22\frac{1}{2}^{\circ} = 69^{\circ}-18'$ $67\frac{1}{2}^{\circ}$		



DESPLAZAMIENTO A 30°-ELEVACION A 45°
CODO INFERIOR A 52°-14'
CODO SUPERIOR A 45°

82

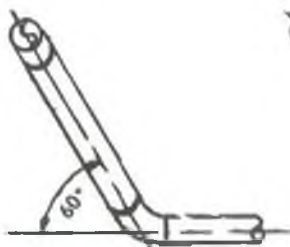

DESPLAZAMIENTO A 60°-ELEVACION A 45°
CODO INFERIOR A 69°-18'
CODO SUPERIOR A 45°



DESPLAZAMIENTOS ESPECIALES
SEIS EJEMPLOS

DESPLAZAMIENTO A 45°
CODO INFERIOR A 45°
CODO SUPERIOR A 60°



DESPLAZAMIENTO A 45°
CODO INFERIOR A 45°
CODO SUPERIOR A 60°



DESPLAZAMIENTO A 22°-30'-ELEVACION A 22°-30'
CODO INFERIOR A 22°-30'
CODO SUPERIOR A 31°-24'

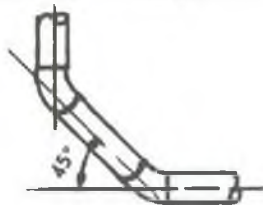

DESPLAZAMIENTO A 45°-ELEVACION A 45°
CODO INFERIOR A 60°
CODO SUPERIOR A 60°

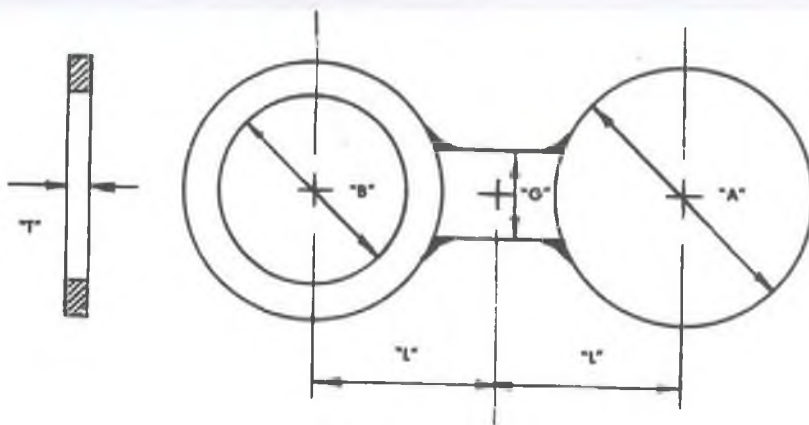

83

MATERIAL

Acero al carbono, A-285-C o semejante
Dejar una tolerancia mínima de 1/8" para el
maquinado al especificar la plancha.

NOTAS:

El grosor está basado en la fórmula
(16) de la norma ASA B31.3-1959

BRIDAS GEMELAS, 150 Y 300 # RF; TUBERIA DE ACERO AL CARBONO

TAMAÑO TUBO	150 # RF - PRES. MAX. = 275 PSI (lb/pul ²) a 100°F					300 # RF - PRES. MAX. = 720 PSI (lb/pul ²) a 100°F				
	A	B	T	L	G	A	B	T	L	G
1	2½	1½ ₆	¼	1½ ₆	1¼	2½	1½ ₆	¼	1½	1½
1½	3¼	1¾	¼	1½ ₆	1½	3¾	1¾	¼	2¼	1½
2	4	2½ ₂	¼	2¾	1½	4¼	2½ ₂	¼	2½	1
2½	4¾	2½ ₂	¼	2¾	1½	5	2½ ₂	¼	2½ ₆	1½
3	5¼	3½ ₂	¼	3	1½	5¾	3½ ₂	¼	3¾ ₆	1½
4	6¾	4½ ₂	¼	3¾	1½	7	4½ ₂	¼	3¾ ₆	1½
6	8¾	6½ ₂	¼	4¾	2	9¼	6½ ₂	¼	5¾ ₆	1¾
8	10¾	8	½	5¾	2	12	8	¾	6¾	2
10	13¾	10½ ₂	¾	7¾	2½	14¾	10½ ₂	1	7¾	1½
12	16	12	¾	8¾	2½	16½	12	1¾	8¾	2
14	17¾	13¾	¾	9¾	2½	19	13¾	1¾	10¾	1¾
16	20¾	15¾	¾	10¾	2½	21¾	15¾	1¾	11¾	1¾
18	21½	17¾	1	11¾	2½	23¾	17¾	1¾	12¾	1½
20	23¾	19¾	1¾	12¾	2½	25¾	19¾	1¾	13¾	1¾
24	28¾	23¾	1¾	14¾	2½	30¾	23¾	2¾	16	2¾

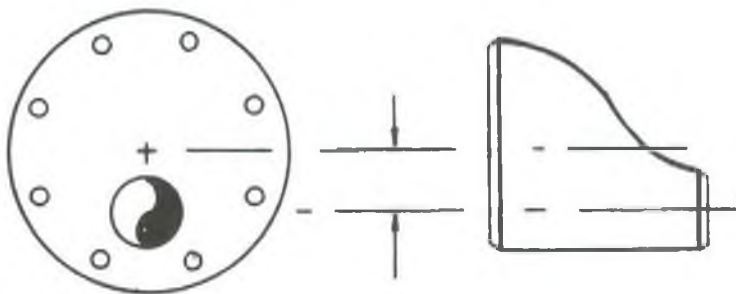

DIMENSIONES CENTRO A CENTRO DE REDUCTORES EXCENTRICOS Y
BRIDAS REDUCTORAS EXCENTRICAS, FABRICADAS A PARTIR DE
BRIDAS CIEGAS.

**DIMENSIONES CENTRO A CENTRO DE REDUCTORES B.W., Y
DIMENSIONES PARA EL TRAZADO DE CORTES EN BRIDAS
EXCENTRICAS CIEGAS**

2 POR	1 = $\frac{1}{2}$	6 POR	$2\frac{1}{2}$ = $1\frac{1}{8}$	14 POR	6 = $3\frac{1}{8}$
	$1\frac{1}{2}$ = $\frac{1}{4}$		3 = $1\frac{1}{8}$		8 = $2\frac{1}{8}$
$2\frac{1}{2}$ POR	1 = $\frac{3}{4}$	8 POR	4 = $1\frac{1}{8}$		10 = $1\frac{3}{8}$
	$1\frac{1}{2}$ = $\frac{1}{2}$		3 = $2\frac{1}{8}$		12 = $\frac{5}{8}$
3 POR	2 = $\frac{1}{4}$	10 POR	4 = $2\frac{1}{8}$	16 POR	6 = $4\frac{1}{8}$
	$1\frac{1}{2}$ = $1\frac{1}{8}$		6 = 1		8 = $3\frac{1}{8}$
	2 = $0\frac{1}{8}$		4 = $3\frac{3}{8}$		10 = $2\frac{5}{8}$
4 POR	$2\frac{1}{2}$ = $\frac{5}{8}$	12 POR	6 = $2\frac{1}{8}$		12 = $1\frac{3}{8}$
	$1\frac{1}{2}$ = $1\frac{5}{8}$		8 = $1\frac{1}{8}$	14 = 1	
	2 = $1\frac{1}{8}$		6 = $3\frac{1}{8}$	8 = $4\frac{1}{8}$	
	$2\frac{1}{2}$ = $1\frac{3}{8}$		8 = $2\frac{1}{8}$	10 = $3\frac{3}{8}$	
	3 = $\frac{1}{2}$		10 = 1	18 POR	12 = $2\frac{3}{8}$
			12 = 2		
			16 = 1		

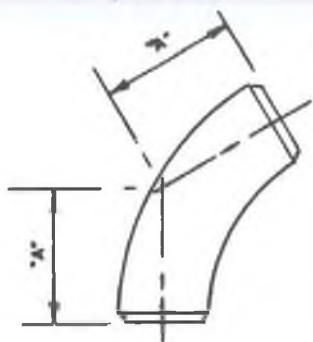

Longitud de trazo de codos
cortados de codos de radio
largo a 90 grados, para
soldadura a tope

15 grados es igual al radio $\times 0.1316$
 $22\frac{1}{2}$ grados es igual al radio $\times 0.1989$
 39 grados es igual al radio $\times 0.2679$
 60 grados es igual al radio $\times 0.3773$

TAMAÑO	15°	22½°	30°	60°
CODO	"A"	"A"	"A"	"A"
1½	$\frac{5}{16}$	$\frac{1}{4}$	$\frac{3}{8}$	$1\frac{1}{8}$
2	$\frac{3}{8}$	$\frac{5}{8}$	$1\frac{1}{8}$	$1\frac{3}{4}$
2½	$\frac{1}{2}$	$\frac{3}{4}$	1	$2\frac{3}{8}$
3	$\frac{5}{8}$	$\frac{7}{8}$	$1\frac{3}{8}$	$2\frac{5}{8}$
4	$1\frac{1}{8}$	$1\frac{3}{8}$	$1\frac{5}{8}$	$3\frac{1}{8}$
6	$1\frac{3}{8}$	$1\frac{13}{16}$	$2\frac{1}{8}$	$5\frac{1}{8}$
8	$1\frac{5}{8}$	$2\frac{3}{8}$	$3\frac{1}{8}$	$6\frac{15}{16}$
10	2	3	4	$8\frac{1}{8}$
12	$2\frac{3}{8}$	$3\frac{3}{8}$	$4\frac{13}{16}$	$10\frac{3}{8}$
14	$2\frac{3}{4}$	$4\frac{3}{8}$	$5\frac{1}{2}$	$12\frac{3}{8}$
16	$3\frac{1}{8}$	$4\frac{3}{4}$	$6\frac{1}{8}$	$13\frac{3}{8}$
18	$3\frac{3}{8}$	$5\frac{3}{8}$	$7\frac{1}{4}$	$15\frac{5}{8}$
20	$3\frac{15}{16}$	6	$8\frac{1}{8}$	$17\frac{3}{8}$
22	$4\frac{3}{8}$	$6\frac{3}{8}$	$8\frac{3}{4}$	$19\frac{3}{8}$
24	$4\frac{3}{4}$	$7\frac{3}{8}$	$9\frac{3}{4}$	$20\frac{3}{8}$

LONGITUD DE LA ROSCA EN TUBERIA
 LONGITUD DE ROSCA EN UN TUBO QUE SE ATORNILLA
 A VALVULAS O ACCESORIOS PARA OBTENER UNA
 JUNTA AJUSTADA

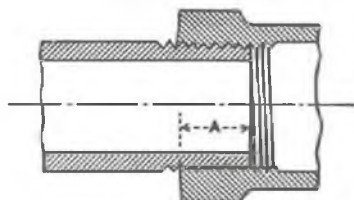

LA CONICIDAD DE LA ROSCA ES 1/16" POR PULGADA

TAMAÑO DEL TUBO	HILOS POR PULGADA	LONGITUD DE LA ROSCA	LONGITUD "A"
$\frac{3}{8}$	27	$\frac{7}{16}$	$\frac{5}{16}$
$\frac{1}{4}$	18	$\frac{5}{8}$	$\frac{7}{16}$
$\frac{5}{8}$	18	$\frac{5}{8}$	$\frac{7}{16}$
$\frac{1}{2}$	14	$1\frac{1}{16}$	$\frac{9}{16}$
$\frac{3}{4}$	14	$1\frac{3}{16}$	$\frac{9}{16}$
1	$11\frac{1}{2}$	1	$1\frac{1}{16}$
$1\frac{1}{4}$	$11\frac{1}{2}$	1	$1\frac{1}{16}$
$1\frac{1}{2}$	$11\frac{1}{2}$	$1\frac{1}{32}$	$1\frac{1}{16}$
2	$11\frac{1}{2}$	$1\frac{1}{16}$	$\frac{3}{4}$
$2\frac{1}{2}$	8	$1\frac{9}{16}$	$1\frac{1}{16}$
3	8	$1\frac{3}{8}$	$1\frac{3}{8}$
4	8	$1\frac{3}{4}$	$1\frac{3}{16}$
6	8	$1\frac{15}{16}$	$1\frac{3}{8}$
8	8	$2\frac{1}{16}$	$1\frac{7}{16}$
10	8	$2\frac{3}{8}$	$1\frac{7}{8}$
12	8	$2\frac{9}{16}$	$1\frac{7}{8}$

ACCESORIOS SOLDABLES
CEDULA 40
MONTAJE, CENTRO A EXTREMO
LONGITUD DE LA PROYECCION

		2	3	4	6	8	10	12
TAMAÑO DE LA SALIDA	1	$2\frac{1}{4}$	$2\frac{13}{16}$	$3\frac{5}{16}$	$4\frac{3}{8}$	$5\frac{1}{8}$	$6\frac{7}{16}$	$7\frac{3}{8}$
	$1\frac{1}{2}$	$2\frac{1}{2}$	$3\frac{1}{16}$	$3\frac{9}{16}$	$4\frac{5}{8}$	$5\frac{5}{8}$	$6\frac{11}{16}$	$7\frac{11}{16}$
	2	$2\frac{11}{16}$	$3\frac{1}{4}$	$3\frac{3}{4}$	$4\frac{13}{16}$	$5\frac{13}{16}$	$6\frac{3}{8}$	$7\frac{7}{8}$
	$2\frac{1}{2}$		$3\frac{3}{8}$	$3\frac{7}{8}$	$4\frac{15}{16}$	$5\frac{15}{16}$	7	8
	3		$3\frac{1}{2}$	4	$5\frac{1}{2}$	$6\frac{1}{16}$	$7\frac{1}{8}$	$8\frac{1}{8}$
	4			$4\frac{1}{4}$	$5\frac{5}{16}$	$6\frac{5}{16}$	$7\frac{3}{8}$	$8\frac{3}{8}$
	6				$5\frac{11}{16}$	$6\frac{11}{16}$	$7\frac{3}{4}$	$8\frac{3}{8}$
	8					$7\frac{1}{16}$	$8\frac{3}{8}$	$9\frac{3}{8}$
	10						$8\frac{7}{16}$	$9\frac{7}{16}$

ACCESORIOS SOLDABLES
CEDULA 80

		2	3	4	6	8	10	12
TAMAÑO DE LA SALIDA	1	$2\frac{1}{4}$	$2\frac{13}{16}$	$3\frac{5}{16}$	$4\frac{3}{8}$	$5\frac{1}{8}$	$6\frac{7}{16}$	$7\frac{3}{8}$
	$1\frac{1}{2}$	$2\frac{1}{2}$	$3\frac{1}{16}$	$3\frac{9}{16}$	$4\frac{5}{8}$	$5\frac{5}{8}$	$6\frac{11}{16}$	$7\frac{11}{16}$
	2	$2\frac{11}{16}$	$3\frac{1}{4}$	$3\frac{3}{4}$	$4\frac{13}{16}$	$5\frac{13}{16}$	$6\frac{3}{8}$	$7\frac{7}{8}$
	$2\frac{1}{2}$		$3\frac{3}{8}$	$3\frac{7}{8}$	$4\frac{15}{16}$	$5\frac{15}{16}$	7	8
	3		$3\frac{1}{2}$	4	$5\frac{1}{2}$	$6\frac{1}{16}$	$7\frac{1}{8}$	$8\frac{1}{8}$
	4			$4\frac{1}{4}$	$5\frac{5}{16}$	$6\frac{5}{16}$	$7\frac{3}{8}$	$8\frac{3}{8}$
	6				$6\frac{3}{8}$	$7\frac{1}{8}$	$8\frac{7}{16}$	$9\frac{1}{8}$
	8					$7\frac{3}{8}$	$9\frac{1}{4}$	$10\frac{1}{4}$
	10						$9\frac{3}{8}$	$10\frac{3}{16}$

SOLDADURA DE CAMPANA

CODOS, TES Y CRUCES

LONGITUDES CENTRO A CENTRO Y DE COLOCACION

	DE CENTRO A CENTRO						DE COLOCACION					
	½"	¾"	1"	1¼"	1½"	2"	½"	¾"	1"	1¼"	1½"	2"
2000#	1¾"	1¾"	1½"	1¾"	2"	2¾"	¾"	¾"	¾"	1¼"	1¼"	1½"
3000#	1¾"	1¾"	1½"	1¾"	2"	2¾"	¾"	¾"	¾"	1¼"	1¼"	1½"
4000#	1¾"	1½"	1¾"	2"	2¾"	2½"	¾"	¾"	1¼"	1¼"	1½"	1¾"
6000#	1¾"	1½"	1¾"	2"	2¾"	2½"	¾"	¾"	1¼"	1¼"	1½"	1¾"

ROSCADA

CODOS, TES Y CRUCES

LONGITUDES CENTRO A CENTRO Y DE COLOCACION

	DE CENTRO A CENTRO						DE COLOCACION					
	½"	¾"	1"	1¼"	1½"	2"	½"	¾"	1"	1¼"	1½"	2"
2000#	1¾"	1¾"	1½"	1¾"	2"	2¾"	¾"	¾"	1¼"	1¼"	1½"	1¾"
3000#	1¾"	1½"	1¾"	2"	2¾"	2½"	¾"	1¼"	1¼"	1½"	1½"	1¾"
6000#	1½"	1¾"	2"	2¾"	2½"	3¼"	1¼"	1¼"	1½"	1½"	1½"	2½"

**VALVULAS BRIDAS DE ACERO FUNDIDO
DIMENSIONES ASA CARA A CARA, EN PULGADAS**

Clase	Tamaño	Tipos de válvulas							
		De compuerta	De globo	> de la línea de cent. con la cara	De retención	Vástago		Bola o esfera	
						Corto	Regular		
150 LB. ¼ R.F.	1½"	6½"	6½"	3½"	6½"	6½"	6½"	6½"	
	2"	7"	8"	4"	8"	7"	7"	7"	
	2½"	7½"	8½"	4½"	8½"	7½"	7½"	7½"	
	3"	8"	9½"	4½"	9½"	8"	8"	8"	
	3½"	8½"	10½"	5"	10½"				
	4"	9"	11½"	5½"	11½"	9"		9"	
	6"	10½"	16"	8"	14"	10½"	15½"	10½"	
	8"	11½"	19½"	9½"	19½"	11½"	18"	11½"	
	10"	13"	24½"	12½"	24½"	13"	21"	13"	
	12"	14"	27½"	13½"	27½"	14"	24"		
	300 LB. ¼ R.F.	1½"	7½"	9"	4½"	9½"	7½"		7½"
		2"	8½"	10½"	5½"	10½"	8½"		8½"
2½"		9½"	11½"	6½"	11½"	9½"			
3"		11½"	12½"	6½"	12½"	11½"		11½"	
4"		12"	14"	7"	14"	12"		12"	
5"		15"	15½"	7½"	15½"				
6"		15½"	17½"	8½"	17½"	15½"	15½"	15½"	
8"		16½"	22"	11"	21"	16½"	19½"	16½"	
10"		18"	24½"	12½"	24½"	18"	22½"	18"	
12"		19½"	28"	14"	28"	19½"			
600 LB. ¼ R.F.		1½"	9½"	9½"	4½"	9½"		9½"	
		2"	11½"	11½"	5½"	11½"		11½"	11½"
	2½"	13"	13"	6½"	13"		13"		
	3"	14"	14"	7"	14"		14"	14"	
	4"	17"	17"	8½"	17"		17"	17"	
	5"	20"	20"	10"					
	6"	22"	22"	11"	22"		22"	22"	
	8"	26"	26"	13"	26"		26"	26"	
	10"	31"	31"	15½"	31"		31"	31"	
	12"	33"	33"	16½"	33"			33"	

8

16

ACCESORIOS BRIDADOS DE ACERO FUNDIDO
CODOS, TES Y CRUCES

150 LB.		300 LB.	
TAMAÑO	CENTRO A CARA	TAMAÑO	CENTRO A CARA
1½	4	1½	4½
2	4½	2	5
2½	5	2½	5½
3	5½	3	6
3½	6	3½	6½
4	6½	4	7
5	7½	5	8
6	8	6	8½
8	9	8	10
10	11	10	11½
12	12	12	13
14	14	14	15
16	15	16	16½
18	16½	18	18
20	18	20	19½
24	22	24	22½

TAMAÑOS Y GROSORES DE LA PARED

TAMAÑO NOMINAL DEL TUBO	DIAMETRO EXTERIOR	GROSOR NOMINAL DE					
		CEDULA 5S (1)	CEDULA 10S (1)	CEDULA 10	CEDULA 20	CEDULA 30	ESTAN-DAR (2)
¾	0.405	—	0.049	—	—	—	0.068
¾	0.540	—	0.065	—	—	—	0.088
¾	0.675	—	0.065	—	—	—	0.091
¾	0.840	0.065	0.083	—	—	—	0.109
¾	1.050	0.065	0.083	—	—	—	0.113
1	1.315	0.065	0.109	—	—	—	0.133
1½	1.660	0.065	0.109	—	—	—	0.140
1½	1.900	0.065	0.109	—	—	—	0.145
2	2.375	0.065	0.109	—	—	—	0.154
2½	2.875	0.083	0.120	—	—	—	0.203
3	3.5	0.083	0.120	—	—	—	0.216
3½	4.0	0.083	0.120	—	—	—	0.226
4	4.5	0.083	0.120	—	—	—	0.237
5	5.563	0.109	0.134	—	—	—	0.258
6	6.625	0.109	0.134	—	—	—	0.280
8	8.625	0.109	0.148	—	0.250	0.277	0.322
10	10.75	0.134	0.165	—	0.250	0.307	0.365
12	12.75	0.156	0.180	—	0.250	0.330	0.375
14 D.E.	14.0	0.156	0.188	0.250	0.312	0.375	0.375
16 D.E.	16.0	0.165	0.188	0.250	0.312	0.375	0.375
18 D.E.	18.0	0.165	0.188	0.250	0.312	0.438	0.375
20 D.E.	20.0	0.188	0.218	0.250	0.375	0.500	0.375
22 D.E.	22.0	0.188	0.218	0.250	0.375	0.500	0.375
24 D.E.	24.0	0.218	0.250	0.250	0.375	0.562	0.375
26 D.E.	26.0	—	—	0.312	0.500	—	0.375
28 D.E.	28.0	—	—	0.312	0.500	0.625	0.375
30 D.E.	30.0	0.250	0.312	0.312	0.500	0.625	0.375
32 D.E.	32.0	—	—	0.312	0.500	0.625	0.375
34 D.E.	34.0	—	—	0.312	0.500	0.625	0.375
36 D.E.	36.0	—	—	0.312	0.500	0.625	0.375
42 D.E.	42.0	—	—	—	—	—	0.375

NOTAS:

1 Los cédulas 5s y 10s se pueden obtener con materiales resistentes a la corrosión, y la cédula 10s también se puede obtener con acero al carbono en tamaños de 12" y menores.

2 Los grosores que aparecen en cursivas se pueden obtener también con acero inoxidable bajo la designación de cédula 40s.

LA PARED PARA							XX FUERTE	
CEDULA 40	CEDULA 60 ③	XS = EXTRA- FUERTE	CEDULA 80	CEDULA 100	CEDULA 120	CEDULA 140	CEDULA 160	DO EXTRA- FUERTE
0.068	—	0.095	0.095	—	—	—	—	—
0.088	—	0.119	0.119	—	—	—	—	—
0.091	—	0.126	0.126	—	—	—	—	—
0.109	—	0.147	0.147	—	—	—	0.188	0.25
0.113	—	0.154	0.154	—	—	—	0.219	0.30
0.133	—	0.179	0.179	—	—	—	0.250	0.35
0.140	—	0.191	0.191	—	—	—	0.250	0.38
0.145	—	0.200	0.200	—	—	—	0.281	0.40
0.154	—	0.218	0.218	—	—	—	0.344	0.45
0.203	—	0.276	0.276	—	—	—	0.375	0.50
0.216	—	0.300	0.300	—	—	—	0.438	0.60
0.226	—	0.318	0.318	—	—	—	—	—
0.237	—	0.337	0.337	—	0.438	—	0.531	0.67
0.258	—	0.375	0.375	—	0.500	—	0.625	0.75
0.280	—	0.432	0.432	—	0.562	—	0.719	0.80
0.322	0.406	0.500	0.500	0.594	0.719	0.812	0.906	0.85
0.365	0.500	0.500	0.594	0.719	0.844	1.000	1.125	1.00
0.406	0.562	0.500	0.688	0.844	1.000	1.125	1.312	1.00
0.438	0.594	0.500	0.750	0.938	1.094	1.250	1.406	—
0.500	0.656	0.500	0.844	1.031	1.219	1.438	1.594	—
0.562	0.750	0.500	0.938	1.156	1.375	1.562	1.781	—
0.594	0.812	0.500	1.031	1.281	1.500	1.750	1.969	—
—	0.875	0.500	1.125	1.375	1.625	1.875	2.125	—
0.688	0.969	0.500	1.218	1.531	1.812	2.062	2.344	—
—	—	0.500	—	—	—	—	—	—
—	—	0.500	—	—	—	—	—	—
—	—	0.500	—	—	—	—	—	—
0.688	—	0.500	—	—	—	—	—	—
0.688	—	0.500	—	—	—	—	—	—
0.750	—	0.500	—	—	—	—	—	—
—	—	0.500	—	—	—	—	—	—

③ Los grosores que aparecen en tipo común para la cédula 60 y tuberías más pesadas no las suministran las plantas laminadoras a menos que se ordene un cierto tonelaje mínimo.

④ Los grosores que aparecen en cursivas también se pueden obtener en acero inoxidable bajo la designación de cédula 80s.

Dimensiones generales

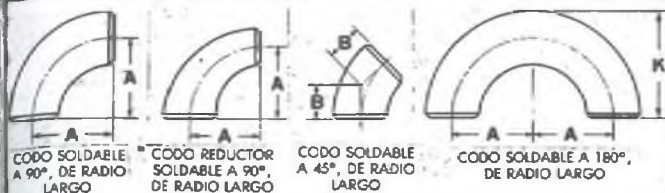

Tamaño nominal del tubo	Diámetro exterior	Espesor nominal de la pared				A	B
		STD ①	XS ②	160	XXS		
3/8	0.840	.109	.147	.187	.294	1 1/2	3/8
1/2	1.050	.113	.154	.218	.308	1 3/4	1/2
3/4	1.315	.133	.179	.250	.358	1 3/4	3/4
1	1.660	.140	.191	.250	.382	1 3/4	1
1 1/2	1.900	.145	.200	.281	.400	2 1/4	1 1/4
2	2.375	.154	.218	.343	.436	3	1 3/4
2 1/2	2.875	.203	.276	.375	.552	3 3/4	1 3/4
3	3.500	.216	.300	.438	.600	4 1/2	2
3 1/2	4.000	.226	.318636	5 1/2	2 1/4
4	4.500	.237	.337	.531	.674	6	2 1/2
5	5.563	.258	.375	.625	.750	7 1/2	3 1/4
6	6.625	.280	.432	.718	.864	9	3 3/4
8	8.625	.322	.500	.906	.875	12	5
10	10.750	.365	.500	1.125	15	6 1/4
12	12.750	.375	.500	1.312	18	7 1/4
14	14.000	.375	.500	1.406	21	8 1/4
16	16.000	.375	.500	1.593	24	10
18	18.000	.375	.500	1.781	27	11 1/4
20	20.000	.375	.500	1.968	30	12 1/2
22	22.000	.375	.500	2.125	33	13 1/2
24	24.000	.375	.500	2.343	36	15
26 *	26.000	.375	.500	39	16
30 *	30.000	.375	.500	45	18 1/2
36 *	36.000	.375	.500	54	22 1/4

① Los grosores estándar de pared son los mismos que los del acero inoxidable de cédula 40s en tamaños hasta 12".

② Los grosores extrafuertes de pared son iguales a los del acero inoxidable de cédula 80s en tamaños hasta 12".

de accesorios soldables



K	D	V	E ³	E ⁴	G	F ASA	Tamaño nominal de tubo
1 1/8	1	1 1/8	3	1/2
1 1/4	1 1/8	1 1/4	3	3/4
1 1/2	1	1 1/8	1 1/2	1 1/2	2	4	1
1 3/4	1 1/4	2 1/8	1 3/4	1 3/4	2 1/2	4	1 1/4
2	2	2	4	1 1/2
2 1/4	1 1/2	2 3/8	2 1/4	2 1/4	3 1/8	6	2
2 1/2	1 3/4	3 1/8	2 1/2	2 1/2	4 1/8	6	2 1/2
2 3/4	2	4 1/8	2 3/4	2 3/4	5 1/8	6	3
3	3	3	6	3 1/2
3 1/4	2 1/4	5 1/8	3 1/4	3 1/4	6 1/8	6	4
3 1/2	2 1/2	6 1/8	3 1/2	3 1/2	7 1/8	8	5
3 3/4	3	7 1/8	3 3/4	3 3/4	8 1/8	8	6
4	4	4	8	8
4 1/4	3 1/4	9 1/8	4 1/4	4 1/4	10 1/8	10	10
4 1/2	3 1/2	10 1/8	4 1/2	4 1/2	11 1/8	10	12
4 3/4	4	11 1/8	4 3/4	4 3/4	12 1/8	10	12
5	5	5	12	14
5 1/4	4 1/4	13 1/8	5 1/4	5 1/4	14 1/8	12	16
5 1/2	4 1/2	14 1/8	5 1/2	5 1/2	15 1/8	12	18
5 3/4	5	15 1/8	5 3/4	5 3/4	16 1/8	12	20
6	6	6	12	22
6 1/4	5 1/4	17 1/8	6 1/4	6 1/4	18 1/8	12	24
6 1/2	5 1/2	18 1/8	6 1/2	6 1/2	19 1/8	12	26 *
6 3/4	6	19 1/8	6 3/4	6 3/4	20 1/8	12	30 *
7	7	7	12	36 *
7 1/4	6 1/4	21 1/8	7 1/4	7 1/4	22 1/8	12	24
7 1/2	6 1/2	22 1/8	7 1/2	7 1/2	23 1/8	12	26 *
7 3/4	7	23 1/8	7 3/4	7 3/4	24 1/8	12	30 *
8	8	8	12	36 *
8 1/4	7 1/4	25 1/8	8 1/4	8 1/4	26 1/8	12	24
8 1/2	7 1/2	26 1/8	8 1/2	8 1/2	27 1/8	12	26 *
8 3/4	8	27 1/8	8 3/4	8 3/4	28 1/8	12	30 *
9	9	9	12	36 *
9 1/4	8 1/4	29 1/8	9 1/4	9 1/4	30 1/8	12	24
9 1/2	8 1/2	30 1/8	9 1/2	9 1/2	31 1/8	12	26 *
9 3/4	9	31 1/8	9 3/4	9 3/4	32 1/8	12	30 *
10	10	10	12	36 *

³ Se aplica a los grosores XS (extrafuerte) o menores.

⁴ Se aplica a los grosores de pared mayores de XS.

*Este tamaño no está cubierto por ASA B16.9.

*Este tamaño no está cubierto por ASA B36.10.

Dimensiones generales



Tamaño nominal del tubo	Solda	Diámetro exterior	Grosor nominal de pared				C	M	N
			STD	XS	160	XXS			
1/2	1/8	.840	.109	.147	.187	.294	1	1
	3/8	.675	.091	.126	1	1
3/4	1/2	1.050	.113	.154	.218	.308	1 1/2	1 1/2
	5/8	.840	.109	.147	.187	.294	1 1/2	1 1/2	1 1/2
1	1	1.315	.133	.179	.250	.358	1 1/2	1 1/2
	3/4	1.050	.113	.154	.218	.308	1 1/2	1 1/2	2
1 1/4	1	1.660	.140	.191	.250	.382	1 1/2	1 1/2
	3/4	1.315	.133	.179	.250	.358	1 1/2	1 1/2	2
1 1/2	1	1.050	.113	.154	.218	.308	1 1/2	1 1/2	2
	3/4	.840	.109	.147	.187	.294	1 1/2	1 1/2	2
2	1 1/2	1.900	.145	.200	.281	.400	2 1/2	2 1/2
	1 1/4	1.660	.140	.191	.250	.382	2 1/2	2 1/2	2 1/2
2 1/2	1 1/2	1.315	.133	.179	.250	.358	2 1/2	2 1/2	2 1/2
	3/4	1.050	.113	.154	.218	.308	2 1/2	2 1/2	2 1/2
3	1 1/2	.840	.109	.147	.187	.294	2 1/2	2 1/2	2 1/2
	1	1.900	.145	.200	.281	.400	2 1/2	2 1/2
4	2	2.375	.154	.218	.343	.436	2 1/2	2 1/2	3
	1 1/2	1.900	.145	.200	.281	.400	2 1/2	2 1/2	3
4 1/2	1 1/2	1.660	.140	.191	.250	.382	2 1/2	2 1/2	3
	1	1.315	.133	.179	.250	.358	2 1/2	2 1/2	3
5	3/4	1.050	.113	.154	.218	.308	2 1/2	1 1/2	3
	1 1/2	2.875	.203	.276	.375	.552	3	3
6	2	2.375	.154	.218	.343	.436	3	2 1/2	3 1/2
	1 1/2	1.900	.145	.200	.281	.400	3	2 1/2	3 1/2
6 1/2	1 1/4	1.660	.140	.191	.250	.382	3	2 1/2	3 1/2
	1	1.315	.133	.179	.250	.358	3	2 1/2	3 1/2

*Este tamaño no está cubierto por ASA B36.10. ASA B16.9

ASA B36.10

de accesorios soldables

REDUCTOR
CONCENTRICO



REDUCTOR
EXCENTRICO



Tam. nom. del tubo	Salida	Diámetro exterior	Grosor nominal de pared				C	M	H
			STD	XS	160	XXS			
3	3	3.500	.216	.300	.438	.600	3 3/8	3 3/8	...
	2 1/2	2.875	.203	.276	.375	.552	3 3/8	3 3/8	3 3/8
	2	2.375	.154	.218	.343	.436	3 3/8	3	3 3/8
	1 1/2	1.900	.145	.200	.281	.400	3 3/8	2 3/8	3 3/8
	1 1/4	1.660	.140	.191	.250	.382	3 3/8	2 3/8	3 3/8
3 1/2	3 1/2	4.000	.226	.318636 †	3 3/8	3 3/8	...
	3	3.500	.216	.300	.438	.600	3 3/8	3 3/8	4
	2 1/2	2.875	.203	.276	.375	.552	3 3/8	3 3/8	4
	2	2.375	.154	.218	.343	.436	3 3/8	3 3/8	4
	1 1/2	1.900	.145	.200	.281	.400	3 3/8	3 3/8	4
4	4	4.500	.237	.337	.531	.674	4 1/8	4 1/8	...
	3 1/2	4.000	.226	.318636 †	4 1/8	4	4
	3	3.500	.216	.300	.438	.600	4 1/8	3 3/8	4
	2 1/2	2.875	.203	.276	.375	.552	4 1/8	3 3/8	4
	2	2.375	.154	.218	.343	.436	4 1/8	3 3/8	4
1 1/2	1.900	.145	.200	.281	.400	4 1/8	3 3/8	4	
5	5	5.563	.258	.375	.625	.750	4 3/8	4 3/8	...
	4	4.500	.237	.337	.531	.674	4 3/8	4 3/8	5
	3 1/2	4.000	.226	.318636 †	4 3/8	4 1/2	5
	3	3.500	.216	.300	.438	.600	4 3/8	4 3/8	5
	2 1/2	2.875	.203	.276	.375	.552	4 3/8	4 3/8	5
2	2.375	.154	.218	.343	.436	4 3/8	4 3/8	5	
6	6	6.625	.280	.432	.718	.864	5 3/8	5 3/8	...
	5	5.563	.258	.375	.625	.750	5 3/8	5 3/8	5 3/8
	4	4.500	.237	.337	.531	.674	5 3/8	5 3/8	5 3/8
	3 1/2	4.000	.226	.318636 †	5 3/8	5	5 3/8
	3	3.500	.216	.300	.438	.600	5 3/8	4 3/8	5 3/8
2 1/2	2.875	.203	.276	.375	.552	5 3/8	4 3/8	5 3/8	

Dimensiones generales

TE
RECTA



TE
REDUCTORA

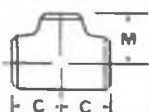

Tom. nom. tubo	Salida	Diám. ext.	Grosor nominal de pared				C	M	M
			STD	XS	160	XXS			
8	8	8.625	.322	.500	.906	.875	7	7	...
	6	6.625	.280	.432	.718	.864	7	6½	6
	5	5.563	.258	.375	.625	.750	7	6½	6
	4	4.500	.237	.337	.531	.674	7	6½	6
	3½	4.000	.226	.318636 †	7	6	6
10	10	10.750	.365	.500	1.125	8½	8½	...
	8	8.625	.322	.500	.906	8½	8	7
	6	6.625	.280	.432	.718	8½	7½	7
	5	5.563	.258	.375	.625	8½	7½	7
	4	4.500	.237	.337	.531	8½	7½	7
12	12	12.750	.375	.500	1.312	10	10	...
	10	10.750	.365	.500	1.125	10	9½	8
	8	8.625	.322	.500	.906	10	9	8
	6	6.625	.280	.432	.718	10	8¾	8
	5	5.563	.258	.375	.625	10	8½	8
14	14	14.000	.375	.500	1.406	11	11	...
	12	12.750	.375	.500	1.312	11	10¾	13
	10	10.750	.365	.500	1.125	11	10¾	13
	8	8.625	.322	.500	.906	11	9¾	13
	6	6.625	.280	.432	.718	11	9¾	13
16	16	16.000	.375	.500	1.593	12	12	...
	14	14.000	.375	.500	1.406	12	12	14
	12	12.750	.375	.500	1.312	12	11¾	14
	10	10.750	.365	.500	1.125	12	11½	14
	8	8.625	.322	.500	.906	12	10¾	14
6	6.625	.280	.432	.718	12	10¾	14	
18	18	18.000	.375	.500	1.781	13½	13½	...
	16	16.000	.375	.500	1.593	13½	13	15
	14	14.000	.375	.500	1.406	13½	13	15

ASA B16.9

ASA B36.10

de accesorios soldables

REDUCTOR
CONCENTRICO



REDUCTOR
EXCENTRICO



Tam. nom. tubo	Salida	Diám. ext.	Grosor nominal da pared				C	M	
			STD	XS	160	XXS			
18	12	12.750	.375	.500	1.312	13½	12½	15
	10	10.750	.365	.500	1.125	13½	12½	15
	8	8.625	.322	.500	.906	13½	11½	15
20	20	20.000	.375	.500	1.968	15	15	20
	18	18.000	.375	.500	1.781	15	14½	20
	16	16.000	.375	.500	1.593	15	14	20
	14	14.000	.375	.500	1.406	15	14	20
	12	12.750	.375	.500	1.312	15	13½	20
	10	10.750	.365	.500	1.125	15	13½	20
	8	8.625	.322	.500	.906	15	12½	20
22	22	22.000	.375	.500	2.125	16½	16½	20
	20	20.000	.375	.500	1.968	16½	16	20
	18	18.000	.375	.500	1.781	16½	15½	20
	16	16.000	.375	.500	1.593	16½	15	20
	14	14.000	.375	.500	1.406	16½	15	20
	12	12.750	.375	.500	1.312	16½	14½	20
	10	10.750	.365	.500	1.125	16½	14½	20
24	24	24.000	.375	.500	2.343	17	17	20
	22	22.000	.375	.500	2.125	17	17	20
	20	20.000	.375	.500	1.968	17	17	20
	18	18.000	.375	.500	1.781	17	16½	20
	16	16.000	.375	.500	1.593	17	16	20
	14	14.000	.375	.500	1.406	17	16	20
	12	12.750	.375	.500	1.312	17	15½	20
	10	10.750	.365	.500	1.125	17	15½	20
30*	30	30.000	.375	.500	22	22	24
	24	24.000	.375	.500	2.343	22	21	24
	22	22.000	.375	.500	2.125	22	20½	24
	20	20.000	.375	.500	1.968	22	20	24
	18	18.000	.375	.500	1.781	22	19½	24
	16	16.000	.375	.500	1.593	22	19	24

*Este tamaño no está cubierto por ASA B16.9

+ Este tamaño no está cubierto por ASA B36.10

Dimensiones generales



BRIDA DE CUELLO SOLDABLE¹



BRIDA DESLIZANTE

125 lb. LW

ASA B16.1

ASA B16.5

A-181-1

Tam. nom. tubo	D.E. de la brida O	Grosor de la brida C 2	Diám. de la cara realizada	Longitud del cubo Y		Barrenada		Diámetro interior maquinado	
				Brida de cuello soldable ¹	Brida deslizante	No. y diámetro de los agujeros	Círculo basal de tornillos	Brida de cuello soldable ¹	Brida deslizante ¹
1/2
3/4
1	4 1/4	3/8	2	1 1/4	4- 5/8	3 3/8	1.05
1 1/4	4 3/8	3/8	2 3/8	1 1/4	4- 5/8	3 1/2	1.38
1 1/2	5	3/8	2 3/8	1 1/4	4- 5/8	3 3/8	1.61
2	6	7/16	3	1 3/4	4- 3/4	4 3/4	2.07
2 1/2	7	1/16	3 1/2	1 3/8	3/8	4- 3/4	5 1/2	2.47	2.94
3	7 1/2	1/2	4	1 1/2	3/8	4- 3/4	6	3.07	3.57
3 1/2	8 1/2	1/2	4 3/4	1 3/8	8- 3/4	7	3.55
4	9	1/2	5 1/2	1 3/8	3/8	8- 3/4	7 1/2	4.13	4.57
5	10	3/16	6 1/2	1 3/8	3/8	8- 3/8	8 1/4	5.05	5.66
6	11	3/16	7 1/2	1 3/8	1 1/4	8- 3/8	9 1/2	6.19	6.72
8	13 1/2	3/16	9 1/2	1 3/8	1 1/4	8- 3/8	11 3/4	8.19	8.72
10	16	11/16	11 3/4	2 3/8	1 1/4	12-1	14 1/4	10.31	10.88
12	19	11/16	13 3/4	2 1/4	1 1/4	12-1	17	12.25	12.88
14	21	3/4	1 1/4	12-1 1/2	18 3/4	14.14
16	23 1/2	3/4	1 1/4	16-1 1/2	21 1/4	16.16
18	25	3/4	1 1/4	16-1 1/4	22 3/4	18.18
20	27 1/2	3/4	1 1/4	20-1 1/4	25	20.20
24	32	1	1 3/4	20-1 3/8	29 1/2	24.25

¹ Los diámetros interiores para tamaños 5", 3 1/2" y menores de las bridas de cuello soldable se maquinan para tuberías de peso estándar. Los de tamaños de 4", 6" y mayores se maquinan para ajustarlas a tuberías de paredes delgadas y para accesorios soldables de distribución de gas. Las bridas deslizantes se maquinan para ajustarlas al D.E. de los tubos de paredes delgadas y para accesorios soldables de distribución de gas.

² Todos los tamaños se suministran comúnmente con caras planas. Si se solicita, se puede suministrar la cara con un realce de 1/32".

de las bridas de acero forjado



BRIDA ROSCADA

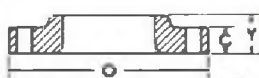

BRIDA PARA JUNTA A TRASLAPE

ASA B16.5

A-181-1

150 lb.

Tam. nom. tubo	D.E. de la brida O	Grosor de la brida C2	Diám. de la cara realzada	Longitud del cubo ²			Barrenado		Diámetro interior maquinado	
				Brida de cuello soldable ¹	Brida deslizante, roscada y de campana	Brida para junta de traslape	No. y diámetro de los agujeros	Circulo basal de tornillos	Brida deslizante	Brida para junta de traslape
½	3½	⅜	1½	1½	¾	¾	4-¾	2¾	.88	.90
¾	3¾	½	1⅞	2⅞	¾	¾	4-¾	2¾	1.09	1.11
1	4¼	⅝	2	2⅞	⅞	⅞	4-¾	3¾	1.36	1.38
1¼	4¾	¾	2½	2¾	⅞	⅞	4-¾	3½	1.70	1.72
1½	5	⅞	2¾	2⅞	¾	¾	4-¾	3¾	1.95	1.97
2	6	¾	3¾	2½	1	1	4-¾	4¼	2.44	2.46
2½	7	¾	4¾	2¾	1½	1½	4-¾	5½	2.94	2.97
3	7½	⅞	5	2¾	1½	1½	4-¾	6	3.57	3.60
3½	8½	⅞	5½	2⅞	1¾	1¾	8-¾	7	4.07	4.10
4	9	⅞	6⅞	3	1½	1½	8-¾	7½	4.57	4.60
5	10	⅞	7⅞	3½	1½	1½	8-¾	8½	5.66	5.69
6	11	1	8½	3½	1½	1½	8-¾	9½	6.72	6.75
8	13½	1½	10¾	4	1¾	1¾	8-¾	11¼	8.72	8.75
10	16	1¾	12¾	4	1¾	1¾	12-1	14¼	10.88	10.92
12	19	1¾	15	4½	2⅞	2⅞	12-1	17	12.88	12.92
14	21	1¾	16¾	5	2¾	3¾	12-1½	18¾	14.14	14.18
16	23½	1¾	18½	5	2½	3⅞	16-1½	21¼	16.16	16.19
18	25	1¾	21	5½	2⅞	3⅞	16-1½	22¼	18.18	18.20
20	27½	1¾	23	5½	2¾	4¼	20-1½	25	20.20	20.25
24	32	1¾	27¼	6	3¼	4¾	20-1½	29½	24.25	24.25

NOTAS:

¹Al hacer el pedido, especifíquese siempre el maquinado del diámetro interior.

²Incluye un realce de 1/16" en los estándares de 150# y 300#. No incluye un realce de 1/4" en los estándares de 400# y más pesados.

Dimensiones generales de

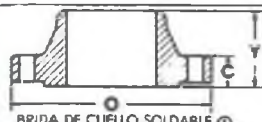

BRIDA DE CUELLO SOLDABLE ①



BRIDA DESLIZANTE

300 lb.

ASA B16.5

A-181-1

Tam. nom. tubo	D.E. de la brida O	Grosor de la brida C ²	Diám. de la cara realzada	Longitud del cubo Y ²			Barrenado		Diám. interior maquinado ³	
				Brida de cuello soldable	Brida deslizando, rescada y de campana	Brida para junta a traslape	No. y diám. de los agujeros	Circulo basal de tornillos	Brida deslizando	Brida para junta a traslape
½	3¼	⅜	1¾	2⅛	¾	¾	4- ⅜	2¾	.88	.90
¾	4⅞	⅝	1⅞	2¼	1	1	4- ¼	3¼	1.09	1.11
1	4⅞	⅞	2	2⅛	1⅛	1⅛	4- ¼	3½	1.36	1.38
1¼	5½	¾	2½	2⅛	1⅛	1⅛	4- ¼	3¾	1.70	1.72
1½	6½	⅞	2¾	2⅛	1⅛	1⅛	4- ⅜	4½	1.95	1.97
2	6½	¾	3¾	2¼	1⅛	1⅛	8- ¼	5	2.44	2.46
2½	7½	1	4½	3	1½	1½	8- ⅜	5¾	2.94	2.97
3	8¼	1¼	5	3¼	1⅞	1⅞	8- ⅜	6¾	3.57	3.60
3½	9	1⅛	5½	3⅞	1¼	1¼	8- ⅜	7¼	4.07	4.10
4	10	1¼	6⅞	3¾	1¾	1¾	8- ⅜	7¾	4.57	4.60
5	11	1¾	7⅞	3¾	2	2	8- ⅜	9¼	5.66	5.69
6	12½	1⅞	8½	3¾	2⅛	2⅛	12- ⅜	10¾	6.72	6.75
8	15	1¾	10¾	4¾	2⅛	2⅛	12-1	13	8.72	8.75
10	17½	1¾	12¾	4¾	2¾	3¾	16-1¼	15¼	10.88	10.92
12	20½	2	15	5¾	2¾	4	16-1¼	17¼	12.88	12.92
14	23	2¼	16¾	5¾	3	4¾	20-1¼	20¾	14.14	14.18
16	25½	2¼	18½	5¾	3¾	4¾	20-1¾	22½	16.16	16.19
18	28	2¾	21	6¼	3¾	5¾	24-1¾	24¼	18.18	18.20
20	30½	2½	23	6¾	3¾	5½	24-1¾	27	20.20	20.25
24	36	2¼	27¼	6¾	4⅞	6	24-1¾	32	24.25	24.25

las bridas de acero forjado



BRIDA ROSCADA



BRIDA PARA JUNTA A TRASLAPE

A-105-1

400 lb.

Tam nom. tubo	D.E. de la brida O	Grosor de la brida C2	Diám. de la cara realizada	Longitud del cubo Y ²			Barrenada		Diám. interior maquinado	
				Brida de cuello soldable ¹	Brida deslizante, rasgada y de campana	Brida para junta a traslape	No. y diám. de los agujeros	Círculo basal de tornillos	Brida deslizante	Brida para junta a traslape
3/8	3/8	1/16	1 1/8	2 1/16	3/8	3/8	4 - 3/8	2 3/8	.88	.90
1/2	4/8	3/16	1 11/16	2 1/4	1	1	4 - 3/4	3 3/4	1.09	1.11
1	4 1/8	11/16	2	2 1/16	1 1/16	1 1/16	4 - 3/4	3 1/2	1.36	1.38
1 1/4	5 1/8	13/16	2 1/2	2 3/8	1 1/4	1 1/4	4 - 3/4	3 3/4	1.70	1.72
1 1/2	6 1/8	3/8	2 3/8	2 3/4	1 1/4	1 1/4	4 - 3/4	4 1/2	1.95	1.97
2	6 1/2	1	3 3/8	2 3/4	1 1/16	1 1/16	8 - 3/4	5	2.44	2.46
2 1/2	7 1/2	1 1/8	4 1/4	3 3/8	1 3/8	1 3/8	8 - 3/4	5 3/4	2.94	2.97
3	8 1/4	1 1/4	5	3 3/4	1 3/16	1 3/16	8 - 3/4	6 3/4	3.57	3.60
3 1/2	9	1 3/8	5 3/8	3 3/4	1 13/16	1 13/16	8-1	7 1/4	4.07	4.10
4	10	1 3/4	6 1/8	3 3/4	2	2	8-1	7 3/4	4.57	4.60
5	11	1 1/2	7 1/8	4	2 1/8	2 1/8	8-1	9 1/4	5.66	5.69
6	12 1/2	1 3/8	8 1/2	4 1/16	2 1/4	2 1/4	12-1	10 3/4	6.72	6.75
8	15	1 3/4	10 3/4	4 3/4	2 11/16	2 11/16	12-1 1/4	13	8.72	8.75
10	17 1/2	2 1/8	12 3/4	4 3/4	2 3/4	4	16-1 1/4	15 1/4	10.88	10.92
12	20 1/2	2 1/4	15	5 3/8	3 3/4	4 1/4	16-1 3/8	17 3/4	12.88	12.92
14	23	2 3/8	16 1/4	5 3/8	3 3/16	4 3/8	20-1 3/8	20 3/4	14.14	14.18
16	25 1/2	2 3/4	18 1/2	6	3 11/16	5	20-1 1/2	22 3/4	16.16	16.19
18	28	2 3/4	21	6 1/2	3 3/8	5 3/8	24-1 1/2	24 3/4	18.18	18.20
20	30 1/2	2 3/4	23	6 3/8	4	5 3/4	24-1 3/4	27	20.20	20.25
24	36	3	27 1/4	6 3/4	4 1/2	6 1/4	24-1 3/4	32	24.25	24.25

NOTAS:

¹ Al hacer el pedido, especifíquese siempre el maquinado del diámetro interior.

² Incluye un realce de 1/16" en los estándares de 150# y 300#. No incluye un realce de 1/4" en los estándares de 400# y más pesados.

Dimensiones generales de



BRIDA DE CUELLO SOLDABLE¹



BRIDA DESLIZANTE

600 lb.

A-105-1

Tam nom. tubo	D.E. de la brida O	Grosor de la brida C2	Diám. de la cara realizada	Longitud del cubo Y ²			Barrenada		Diám. interior maquinado	
				Brida de cuello soldable ¹	Brida deslizante, rasgada, y de campana	Brida para junta a traslape	No. y diám. de los agujeros	Círculo basal de tornillos	Brida deslizante	Brida para junta a traslape
3/8	3/8	1/16	1 1/8	2 1/16	3/8	3/8	4 - 3/8	2 3/8	.88	.90
1/2	4 3/8	3/16	1 11/16	2 1/4	1	1	4 - 3/4	3 3/4	1.09	1.11
1	4 1/8	11/16	2	2 1/16	1 1/16	1 1/16	4 - 3/4	3 1/2	1.36	1.38
1 1/4	5 1/8	13/16	2 1/2	2 3/8	1 1/4	1 1/4	4 - 3/4	3 3/4	1.70	1.72
1 1/2	6 1/8	3/8	2 3/8	2 3/4	1 1/4	1 1/4	4 - 3/4	4 1/2	1.95	1.97
2	6 1/2	1	3 3/8	2 3/4	1 1/16	1 1/16	8 - 3/4	5	2.44	2.46
2 1/2	7 1/2	1 1/8	4 1/4	3 3/8	1 3/8	1 3/8	8 - 3/4	5 3/4	2.94	2.97
3	8 1/4	1 1/4	5	3 3/4	1 3/16	1 3/16	8 - 3/4	6 3/4	3.57	3.60
3 1/2	9	1 3/8	5 3/8	3 3/4	1 13/16	1 13/16	8-1	7 1/4	4.07	4.10
4	10	1 3/4	6 1/8	3 3/4	2	2	8-1	7 3/4	4.57	4.60
5	11	1 1/2	7 1/8	4	2 1/8	2 1/8	8-1	9 1/4	5.66	5.69
6	12 1/2	1 3/8	8 1/2	4 1/16	2 1/4	2 1/4	12-1	10 3/4	6.72	6.75
8	15	1 3/4	10 3/4	4 3/4	2 11/16	2 11/16	12-1 1/4	13	8.72	8.75
10	17 1/2	2 1/8	12 3/4	4 3/4	2 3/4	4	16-1 1/4	15 1/4	10.88	10.92
12	20 1/2	2 1/4	15	5 3/8	3 3/4	4 1/4	16-1 3/8	17 3/4	12.88	12.92
14	23	2 3/8	16 1/4	5 3/8	3 3/16	4 3/8	20-1 3/8	20 3/4	14.14	14.18
16	25 1/2	2 3/4	18 1/2	6	3 11/16	5	20-1 1/2	22 3/4	16.16	16.19
18	28	2 3/4	21	6 1/2	3 3/8	5 3/8	24-1 1/2	24 3/4	18.18	18.20
20	30 1/2	2 3/4	23	6 3/8	4	5 3/4	24-1 3/4	27	20.20	20.25
24	37	4	27 1/4	8	5 1/2	7 1/4	24-2	33	24.25	24.25

las bridas de acero forjado



BRIDA ROSCADA



BRIDA PARA JUNTA A TRASLAPE

ASA B16.5

A-105-II

900 lb.

Tam. nom. tubo	D.E. de la brida O	Grosor de la brida C2	Diám. de la cara realzada	Longitud del cubo Y ²			Barronado		Diám. interior maquinado	
				Brida de cuello soldable ²	Brida deslizante, roscada, y de campana	Brida para junta a traslape	No. y diám. de los agujeros	Circulo basal de tornillos	Brida deslizante	Brida para junta a traslape
1/2	4 3/4	3/8	1 3/8	2 3/8	1 1/4	1 1/4	4- 1/2	3 3/4	.88	.90
3/4	5 1/2	1	1 11/16	2 3/4	1 3/8	1 3/8	4- 3/8	3 1/2	1.09	1.11
1	5 7/8	1 1/8	2	2 3/8	1 3/8	1 3/8	4-1	4	1.36	1.38
1 1/4	6 1/2	1 1/4	2 1/2	2 3/8	1 3/8	1 3/8	4-1	4 3/8	1.70	1.72
1 1/2	7	1 1/2	2 3/8	3 3/4	1 3/4	1 3/4	4-1 1/2	4 3/8	1.95	1.97
2	8 1/2	1 1/2	3 3/8	4	2 1/4	2 1/4	8-1	6 1/2	2.44	2.46
2 1/2	9 3/8	1 3/8	4 1/8	4 1/4	2 1/2	2 1/2	8-1 1/8	7 1/2	2.94	2.97
3	9 1/2	1 1/2	5	4	2 3/8	2 3/8	8-1	7 1/2	3.57	3.60
3 1/2	---	---	---	---	---	---	---	---	---	---
4	11 1/2	1 3/4	6 3/16	4 1/2	2 3/4	2 3/4	8-1 1/4	9 1/4	4.57	4.60
5	13 3/4	2	7 3/16	5	3 3/8	3 3/8	8-1 3/8	11	5.66	5.69
6	15	2 3/16	8 1/2	5 1/2	3 3/8	3 3/8	12-1 1/4	12 1/2	6.72	6.75
8	18 1/2	2 1/2	10 3/8	6 3/8	4	4 1/2	12-1 1/2	15 1/2	8.72	8.75
10	21 1/2	2 3/4	12 3/4	7 1/4	4 1/4	5	16-1 1/2	18 1/2	10.88	10.92
12	24	3 1/8	15	7 3/8	4 3/8	5 3/8	20-1 1/2	21	12.88	12.92
14	25 1/4	3 3/8	16 1/4	8 3/8	5 1/8	6 1/8	20-1 3/4	22	14.14	14.18
16	27 3/4	3 1/2	18 1/2	8 1/2	5 1/4	6 1/2	20-1 3/4	24 1/4	16.16	16.19
18	31	4	21	9	6	7 1/2	20-2	27	18.18	18.20
20	33 3/4	4 1/4	23	9 3/4	6 1/4	8 1/4	20-2 1/8	29 1/2	20.20	20.25
24	41	5 1/2	27 1/4	11 1/2	8	10 1/2	20-2 3/8	35 1/2	24.25	24.25

NOTAS:

¹Al hacer el pedido, especifíquese siempre el maquinado del diámetro interior.

²Incluye un realce de 1/16" en los estándares de 150 # y 300 #

No incluye el realce de 1/4" en los estándares de 400 # y más pesados.

Dimensiones generales de



BRIDA DE CUELLO SOLDABLE



BRIDA DESLIZANTE

1500 lb.

A-105-II

Tamaño nominal del tubo	D.E. de la brida O	Grosor de la brida C ²	Diámetro de la cara realzada	Longitud del cubo Y ²			Barrenado		Diámetro interior maquinado	
				Brida de cuello soldable ¹	Brida deslizante, rosca, y de campana	Brida para junta a traslape	No. y diámetro de los agujeros	Círculo basal de tornillos	Brida deslizante	Brida para junta a traslape
½	4¾	¾	1¾	2¾	1¼	1¼	4- ⅜	3¼	.88	.90
¾	5½	1	1 ¹¹ / ₁₆	2¾	1¾	1¾	4- ⅞	3½	1.09	1.11
1	5¾	1¼	2	2¾	1¾	1¾	4-1	4	1.36	1.38
1¼	6¼	1¼	2½	2¾	1¾	1¾	4-1	4¾	1.70	1.72
1½	7	1¼	2¾	3¼	1¾	1¾	4-1½	4¾	1.95	1.97
2	8½	1½	3¼	4	2¼	2¼	8-1	6½	2.44	2.46
2½	9¾	1¾	4¼	4¼	2½	2½	8-1½	7½	2.94	2.97
3	10½	1¾	5	4¾	2¾	2¾	8-1½	8	3.57	3.60
3½
4	12¼	2¼	6 ¹ / ₁₆	4¾	3 ³ / ₁₆	3 ³ / ₁₆	8-1¾	9½	4.57	4.60
5	14¼	2¼	7 ¹ / ₁₆	6¾	4¾	4¾	8-1¾	11½	5.66	5.69
6	15½	3¼	8½	6¾	4 ¹¹ / ₁₆	4 ¹¹ / ₁₆	12-1½	12¼	6.72	6.75
8	19	3¾	10¾	8¾	5¾	5¾	12-1¾	15½	8.72	8.75
10	23	4¼	12¾	10	6¾	7	12-2	19	10.88	10.92
12	26½	4¾	15	11¾	7¾	8¾	16-2¼	22½	12.88	12.92
14	29½	5¼	16¼	11¼	...	9½	16-2¾	25	14.14	14.18
16	32½	5¼	18½	12¼	...	10¼	16-2¾	27¾	16.16	16.19
18	36	6¾	21	12¾	...	10¾	16-2¾	30½	18.18	18.20
20	38¼	7	23	14	...	11½	16-3¼	32¾	20.20	20.25
24	46	8	27¼	16	...	13	16-3¾	39	24.25	24.25

las bridas de acero forjado



BRIDA ROSCADA



BRIDA PARA JUNTA A TRASLAPE

ASA B16.5

A-105-II

2500 lb.

Tamaño nominal del tubo	D.E. de la brida O	Grosor de la brida C ²	Diámetro de la cara realzada	Longitud del cubo Y ²			Barrenado		Diámetro interior maquinado	
				Brida de cuello soldable	Brida deslizante y roscada	Brida para junta a traslape	No. y diámetro de los agujeros	Círculo basal de tornillos	Brida deslizante	Brida para junta a traslape
½	5¼	1⅛	1¾	2¾	1⅞	1⅞	4 - ¾	3½	.88	.90
¾	5½	1¼	1⅞	3¾	1⅞	1⅞	4 - ¾	3¾	1.09	1.11
1	6¼	1¾	2	3½	1¾	1¾	4-1	4¼	1.36	1.38
1¼	7¼	1½	2½	3¾	2⅞	2⅞	4-1½	5¼	1.70	1.72
1¾	8	1¾	2¾	4¼	2¾	2¾	4-1¼	5¼	1.95	1.97
2	9¼	2	3¾	5	2¾	2¾	8-1½	6¼	2.44	2.46
2½	10½	2¼	4¼	5¾	3¾	3¾	8-1¼	7¼	2.94	2.97
3	12	2¾	5	6¾	3¾	3¾	8-1¾	9	3.57	3.60
3½
4	14	3	6¼	7¼	4¼	4¼	8-1¾	10¼	4.57	4.60
5	16½	3¾	7¼	9	5¼	5¼	8-1¾	12¼	5.66	5.69
6	19	4¼	8½	10¼	6	6	8-2¼	14½	6.72	6.75
8	21¼	5	10¾	12½	7	7	12-2¾	17¼	8.72	8.75
10	26½	6½	12¾	16½	9	9	12-2¾	21¼	10.88	10.92
12	30	7¼	15	18¼	10	10	12-2¾	24¾	12.88	12.92

NOTAS:

¹Al hacer el pedido, especifíquese siempre el maquinado del diámetro interior.

²Incluye un realce de 1/16" en los estándares de 150 # y 300 #

No incluye un realce en 1/4" en los estándares de 400 # y más pesados.

BRIDAS SERIE 150

TAMAÑO DEL TUBO	PERNOS DE LAS BRIDAS		CARA REALIZADA				JUNTA ANULAR LONG. DEL ESPARRAGO	ANILLO NO.	CLARO DEL ANILLO
	CANTIDAD	TAMAÑO	LONGITUD		JUNTA				
			ESPARRAGOMINADO	D.I.	D.E.				
1/2	4	1/2	2 1/4	1 3/4	1/8	1 1/4			
3/4	4	1/2	2 1/4	2	1 1/4	2 1/4			
1	4	1/2	2 1/2	2	1	2 3/8	3	R-15	
1 1/4	4	1/2	2 3/4	2 1/4	1 1/8	3	3	R-17	
1 1/2	4	1/2	2 3/4	2 1/4	1 1/8	3 3/4	3 1/4	R-19	
2	4	3/4	3	2 3/4	2	4 1/4	3 1/2	R-22	
2 1/2	4	3/4	3 1/4	3	2 1/2	4 3/4	3 3/4	R-25	
3	4	1/2	3 1/2	3	3	5 1/4	4	R-29	
3 1/2	8	3/4	3 1/2	3	3 1/2	6 3/4	4	R-33	
4	8	3/4	3 1/2	3	4	6 3/4	4	R-36	
5	8	3/4	3 3/4	3 1/4	5	7 3/4	4 1/4	R-40	
6	8	3/4	3 3/4	3 1/4	6	8 3/4	4 1/4	R-43	
8	8	3/4	4	3 1/2	8	11	4 1/2	R-48	
10	12	1/2	4 1/2	3 3/4	10	13 1/4	5	R-52	
12	12	1/2	4 1/2	4	12	16 1/4	5	R-56	
14	12	1	5	4 1/4	13 1/4	17 1/4	5 1/2	R-59	
16	16	1	5 1/4	4 1/2	15 1/4	20 1/4	5 1/2	R-64	
18	16	1 1/4	5 3/4	4 3/4	17 1/4	21 1/4	6 1/4	R-68	
20	20	1 1/4	6	5 1/4	19 1/4	23 1/4	6 1/4	R-72	
22	20	1 1/4	6 1/4	5 1/2	21 1/4	26	7	R-80	
24	20	1 1/4	6 3/4	5 3/4	23 1/4	28 1/4	7 1/4	R-76	

BRIDAS SERIE 300

TAMARO DEL TURO	PERNOS DE LAS BRIDAS		CARA REALIZADA:				JUNTA ANULAR		CLARO DEL ANILLO
	CANTIDAD	TAMARO	LONGITUD		D.E.	LONG. DEL ESPARRAGO	ANILLO NO.		
			ESPARRAGOMAJINADC	D.I.					
1/2	4	1/2	2 1/2	2	3/4	2 1/4	3	R-11	1/4
3/4	4	5/8	2 3/4	2 1/2	1 1/2	2 3/4	3 1/4	R-13	5/8
1	4	3/4	3	2 1/2	1	2 1/4	3 1/2	R-16	-
1 1/4	4	5/8	3	2 3/4	1 1/4	3 1/4	3 1/2	R-18	-
1 1/2	4	3/4	3 1/2	3	1 1/4	3 3/4	4	R-20	-
2	8	3/4	3 1/4	3	2	4 1/4	4	R-23	1/2
2 1/2	8	3/4	3 3/4	3 1/4	2 1/2	5 1/4	4 1/2	R-26	-
3	8	3/4	4	3 1/2	3	5 1/4	4 1/2	R-31	-
3 1/2	8	3/4	4 1/4	3 3/4	3 1/2	6 1/4	5	R-34	-
4	8	3/4	4 1/4	3 3/4	4	7 1/4	5	R-37	-
5	8	3/4	4 1/2	4 1/2	5	8 1/4	5 1/2	R-41	-
6	12	3/4	4 1/2	4 1/2	6	9 1/4	5 1/2	R-45	-
8	12	1/2	5 1/4	4 1/2	8	12 1/4	6	R-49	-
10	16	1	6	5 1/4	10	14 1/4	6 1/4	R-53	-
12	16	1 1/4	6 1/2	5 3/4	12	16 1/4	7 1/4	R-57	-
14	20	1 1/2	6 3/4	6	13 1/4	19 1/4	7 1/2	R-61	-
16	20	1 1/4	7 1/4	6 1/2	15 1/4	21 1/4	8	R-65	-
18	24	1 1/4	7 1/2	6 1/2	17	23 1/2	8 1/4	R-69	-
20	24	1 1/4	8	7	19	25 1/4	8 3/4	R-73	-
22	24	1 1/2	8 3/4	7 1/2	21	27 3/4	9 1/4	R-81	-

BRIDAS SERIE 400

TAM. DEL TUBO	PERNOS DE LAS BRIDAS		LONGITUD DE LOS ESPARRAGOS			*ANI- LLO NO.	CLARO DEL ANILLO
			CARA REAL- ZADA	MACHO Y HEMBRA, RANURA Y CEJA	JUNTA ANU- LAR		
	CANT.	TAM.					
4	8	$\frac{3}{8}$	$5\frac{1}{4}$	5	$5\frac{1}{2}$	R-37	$\frac{7}{32}$
5	8	$\frac{3}{8}$	$5\frac{1}{2}$	$5\frac{1}{4}$	$5\frac{3}{4}$	R-41	-
6	12	$\frac{3}{8}$	$5\frac{3}{4}$	$5\frac{1}{2}$	6	R-45	-
8	12	1	$6\frac{1}{2}$	$6\frac{1}{4}$	$6\frac{3}{4}$	R-49	-
10	16	$1\frac{1}{8}$	$7\frac{1}{4}$	7	$7\frac{1}{2}$	R-53	-
12	16	$1\frac{1}{4}$	$7\frac{3}{4}$	$7\frac{1}{2}$	8	R-57	-
14	20	$1\frac{1}{4}$	8	$7\frac{3}{4}$	$8\frac{1}{4}$	R-61	-
16	20	$1\frac{3}{8}$	$8\frac{1}{2}$	$8\frac{1}{4}$	$8\frac{3}{4}$	R-65	-
18	24	$1\frac{3}{8}$	$8\frac{3}{4}$	$8\frac{1}{2}$	9	R-69	-
20	24	$1\frac{1}{2}$	$9\frac{1}{2}$	$9\frac{1}{4}$	$9\frac{3}{4}$	R-73	-
22	24	$1\frac{1}{2}$	10	$9\frac{3}{4}$	$10\frac{1}{2}$	R-81	$\frac{1}{16}$
24	24	$1\frac{3}{4}$	$10\frac{1}{2}$	$10\frac{1}{4}$	11	R-77	$\frac{1}{8}$

*Las series 300, 400 y 660 usan los mismos números de anillo.

BRIDAS SERIE 600

TAM. DEL TUBO	PERNOS DE LAS BRIDAS		LONGITUD DE LOS ESPARRAGOS			*ANI- LLO NO.	CLARO DEL ANILO
			CARA REAL- ZADA	MACHO Y HEMBRA, RANURA Y CEJA	JUNTA ANU- LAR		
	CANT.	TAM.					
½	4	⅜	3	2¾	3	R-11	⅜
¾	4	⅜	3¼	3	3¼	R-13	⅜
1	4	⅜	3½	3¼	3½	R-16	-
1¼	4	⅜	3¾	3½	3¾	R-18	-
1½	4	¾	4	3¾	4	R-20	-
2	8	¾	4	3¾	4¼	R-23	¾
2½	8	¾	4½	4¾	4¾	R-26	-
3	8	¾	4¾	4½	5	R-31	-
3½	8	¾	5¼	5	5½	R-34	-
4	8	¾	5½	5¼	5¾	R-37	-
5	8	1	6¼	6	6½	R-41	-
6	12	1	6½	6¼	6¾	R-45	-
8	12	1½	7½	7¾	7¾	R-49	-
10	16	1¼	8¼	8	8½	R-53	-
12	20	1¼	8½	8¾	8¾	R-57	-
14	20	1¾	9	8¾	9¼	R-61	-
16	20	1½	9¾	9½	10	R-65	-
18	20	1¾	10½	10¼	10¾	R-69	-
20	24	1¾	11¼	11	11½	R-73	-
22	24	1¼	12	11¼	12½	R-81	-
24	24	1¾	12¾	12½	13¼	R-77	¾

*Las series 300, 400 y 600 usan los mismos números de anillo.

BRIDAS SERIE 900

TAM. DEL TUBO	PERNOS DE LAS BRIDAS		LONGITUD DE LOS ESPARRAGOS			ANILO NO.	CLARO DEL ANILO
			CARA REAL- ZADA	MACHO Y HEMBRA, RANURA Y CEJA	JUNTA ANU- LAR		
	CANT.	TAM.					
3	8	¾	5½	5¼	5¾	R-31	¾
4	8	1¼	6½	6¼	6¾	R-37	-
5	8	1¼	7¼	7	7½	R-41	-
6	12	1¾	7½	7¼	7½	R-45	-
8	12	1¾	8½	8¼	8¾	R-49	-
10	16	1¾	9	8¾	9¼	R-53	-
12	20	1¾	9¼	9½	10	R-57	-
14	20	1½	10½	10¼	11	R-62	-
16	20	1¾	11	10¾	11½	R-66	-
18	20	1¾	12¼	12½	13¼	R-70	¾
20	20	2	13½	13¼	14	R-74	-
24	20	2½	17	16¾	17¾	R-78	¾

BRIDAS SERIE 1500

TAM. DEL TUBO	PERNOS DE LAS BRIDAS		LONGITUD DE LOS ESPARRAGOS			ANILLO NO.	CLARO DEL ANILLO
			CARA REAL- ZADA	MACHO Y HEMERA, RANURA Y CEJA	JUNTA ANU- LAR		
	CANT.	TAM.					
1/2	4	3/8	4	3 3/8	4	R-12	3/32
3/4	4	3/8	4 1/4	4	4 3/8	R-14	-
1	4	7/8	4 3/4	4 1/2	4 3/4	R-16	-
1 1/4	4	7/8	4 3/4	4 1/2	4 3/4	R-18	-
1 1/2	4	1	5 1/4	5	5 3/8	R-20	-
2	8	7/8	5 1/2	5 1/4	5 3/4	R-24	1/8
2 1/2	8	1	6	5 3/4	6 1/4	R-27	-
3	8	1 1/8	6 1/2	6 1/2	7	R-35	-
4	8	1 1/4	7 1/2	7 1/4	7 3/4	R-39	-
5	8	1 1/2	9 1/2	9 1/4	9 3/8	R-44	-
6	12	1 3/8	10	9 3/4	10 1/4	R-46	-
8	12	1 5/8	11 1/4	11	11 3/8	R-50	3/32
10	12	1 3/4	13 1/4	13	13 1/2	R-54	-
12	16	2	14 3/4	14 1/2	15 1/4	R-58	3/16
14	16	2 1/4	16	15 3/4	16 3/4	R-63	7/32
16	16	2 1/2	17 1/2	17 1/4	18 1/2	R-67	5/16
18	16	2 3/4	19 1/4	19	20 1/4	R-71	-
20	16	3	21	20 3/4	22 1/4	R-75	3/8
24	16	3 1/2	24	23 3/4	25 1/2	R-79	1/4

BRIDAS SERIE 2500

TAM. DEL TUBO	PERNOS DE LAS BRIDAS		LONGITUD DE LOS ESPARRAGOS			ANILLO NO.	CLARO DEL ANILLO
			CARA REAL- ZADA	MACHO Y HEMBRA, RANURA Y CEJA	JUNTA ANU- LAR		
	CANT.	TAM.					
$\frac{1}{2}$	4	$\frac{3}{4}$	$4\frac{3}{4}$	$4\frac{1}{2}$	$4\frac{3}{4}$	R-13	$\frac{1}{32}$
$\frac{3}{4}$	4	$\frac{3}{4}$	$4\frac{3}{4}$	$4\frac{1}{2}$	$4\frac{3}{4}$	R-16	-
1	4	$\frac{7}{8}$	$5\frac{1}{4}$	5	$5\frac{1}{4}$	R-18	-
$1\frac{1}{4}$	4	1	$5\frac{3}{4}$	$5\frac{1}{2}$	6	R-21	$\frac{1}{8}$
$1\frac{1}{2}$	4	$1\frac{1}{8}$	$6\frac{1}{2}$	$6\frac{3}{4}$	$6\frac{3}{4}$	R-23	-
2	8	1	$6\frac{3}{4}$	$6\frac{1}{2}$	7	R-26	-
$2\frac{1}{2}$	8	$1\frac{1}{8}$	$7\frac{1}{2}$	$7\frac{1}{4}$	$7\frac{3}{4}$	R-28	-
3	8	$1\frac{1}{4}$	$8\frac{1}{2}$	$8\frac{1}{4}$	$8\frac{3}{4}$	R-32	-
4	8	$1\frac{1}{2}$	$9\frac{3}{4}$	$9\frac{1}{2}$	$10\frac{1}{4}$	R-38	$\frac{1}{32}$
5	8	$1\frac{3}{4}$	$11\frac{1}{2}$	$11\frac{1}{4}$	$12\frac{1}{4}$	R-42	-
6	8	2	$13\frac{1}{2}$	$13\frac{1}{4}$	14	R-47	-
8	12	2	15	$14\frac{3}{4}$	$15\frac{1}{2}$	R-51	$\frac{1}{16}$
10	12	$2\frac{1}{2}$	19	$18\frac{3}{4}$	20	R-55	$\frac{1}{4}$
12	12	$2\frac{3}{4}$	21	$20\frac{3}{4}$	22	R-60	$\frac{3}{16}$

TAMAÑO DE LAS LLAVES DE TUERCAS

DIAMETRO DEL PERNO	TAMAÑO DE LA LLAVE	DIAMETRO DEL PERNO	TAMAÑO DE LA LLAVE
$\frac{1}{2}$	$\frac{7}{8}$	$1\frac{1}{8}$	$2\frac{5}{16}$
$\frac{3}{8}$	$1\frac{1}{16}$	$1\frac{1}{4}$	$2\frac{3}{4}$
$\frac{3}{4}$	$1\frac{1}{4}$	$1\frac{1}{2}$	$2\frac{11}{16}$
$\frac{7}{8}$	$1\frac{7}{8}$	2	$3\frac{3}{8}$
1	$1\frac{5}{8}$	$2\frac{1}{4}$	$3\frac{1}{2}$
$1\frac{1}{8}$	$1\frac{11}{16}$	$2\frac{1}{2}$	$3\frac{1}{8}$
$1\frac{1}{4}$	2	$2\frac{3}{4}$	$4\frac{1}{4}$
$1\frac{3}{4}$	$2\frac{3}{16}$	3	$4\frac{5}{8}$
$1\frac{1}{2}$	$2\frac{1}{2}$	$3\frac{1}{2}$	$5\frac{3}{8}$

TAMAÑOS DE LAS BROCAS PARA MACHUELOS DE TUBERIA

Tamaño del machuelo en pulgadas	No. de hilos por pulgada	Diámetro de la broca	Tamaño del machuelo en pulgadas	No. de hilos por pulgada	Diámetro de la broca
$\frac{3}{8}$	27	$\frac{11}{32}$	2	$11\frac{1}{2}$	$2\frac{3}{16}$
$\frac{3}{4}$	18	$\frac{7}{16}$	$2\frac{1}{2}$	8	$2\frac{9}{16}$
$\frac{3}{4}$	18	$3\frac{17}{64}$	3	8	$3\frac{3}{16}$
$\frac{3}{2}$	14	$\frac{23}{32}$	$3\frac{1}{2}$	8	$3\frac{11}{16}$
$\frac{3}{4}$	14	$\frac{59}{64}$	4	8	$4\frac{3}{16}$
1	$11\frac{1}{2}$	$\frac{1}{2}$	$4\frac{1}{2}$	8	$4\frac{1}{2}$
$1\frac{1}{8}$	$11\frac{1}{2}$	$1\frac{1}{2}$	5	8	$5\frac{3}{16}$
$1\frac{1}{2}$	$11\frac{1}{2}$	$1\frac{49}{64}$	6	8	$6\frac{5}{16}$

TAMAÑO DE LAS BROCAS Y MACHUELOS (American Standard Coarse; rosca estándar)

Tamaño de la broca	Tamaño del machuelo	Hilos por pulgada	Tamaño de la broca	Tamaño del machuelo	Hilos por pulgada
7	$\frac{1}{4}$	20	$\frac{49}{64}$	$\frac{3}{8}$	9
F	$\frac{5}{16}$	18	$\frac{53}{64}$	$\frac{25}{16}$	9
$\frac{5}{16}$	$\frac{3}{8}$	16	$\frac{7}{8}$	1	8
U	$\frac{7}{16}$	14	$\frac{63}{64}$	$1\frac{1}{8}$	7
$\frac{27}{64}$	$\frac{1}{2}$	13	$1\frac{1}{4}$	$1\frac{1}{4}$	7
$\frac{21}{64}$	$\frac{9}{16}$	12	$1\frac{13}{64}$	$1\frac{1}{8}$	6
$\frac{17}{32}$	$\frac{5}{8}$	11	$1\frac{11}{32}$	$1\frac{1}{2}$	6
$\frac{19}{32}$	$1\frac{1}{16}$	11	$1\frac{29}{64}$	$1\frac{3}{8}$	$5\frac{1}{2}$
$\frac{21}{32}$	$\frac{3}{4}$	10	$1\frac{11}{16}$	$1\frac{1}{2}$	5
$\frac{23}{32}$	$1\frac{1}{8}$	10	$1\frac{13}{16}$	$1\frac{1}{2}$	$4\frac{1}{2}$
			$1\frac{25}{32}$	2	$4\frac{1}{2}$

TABLAS PARA PERNOS EN BRIDAS DE ORIFICIO DE 300 Y 400 LB

TAMAÑO NOMINAL DE LA TUBERIA	PERNOS DE LAS BRIDAS		LONGITUD DEL ESPARRAGO PARA EL ORIFICIO DE 300 LB		TAMAÑO NOMINAL DE LA TUBERIA	PERNOS DE LAS BRIDAS		LONGITUD DEL ESPARRAGO PARA EL ORIFICIO DE 400 LB	
	CANTIDAD	TAMAÑO	RF	RTJ		CANTIDAD	TAMAÑO	RF	RTJ
1	4	3/8	4	4 3/4	NOTA: 1	8	3/8	5 1/2	6
1 1/4	4	3/8	4	4 3/4		8	3/8	5 3/4	6 1/4
1 1/2	4	3/4	4 1/4	5		12	3/8	6 1/4	6 1/2
2	8	3/8	4	4 3/4		12	1	6 3/4	7 1/4
2 1/2	8	3/4	4 1/4	5		16	1 1/8	7 5/8	8
3	8	3/4	4 1/4	5		16	1 1/4	8	8 1/2
4	8	3/4	4 1/4	5 1/2		20	1 1/4	8 1/4	9
5	8	3/4	4 1/4	5 1/2		20	1 3/8	8 3/4	9 1/4
6	12	3/4	4 1/4	5 1/2		24	1 3/8	9 1/4	9 1/2
8	12	7/8	4 1/2	6		24	1 1/2	9 3/4	10 1/4
10	16	1	5 1/2	6 1/2		24	1 3/4	10 1/2	10 3/4
12	16	1 1/8	5 1/2	7		24	1 3/4	11	11 1/4
14	20	1 1/8	6	7					
16	20	1 1/4	6 1/2	8					
18	24	1 1/4	6 3/2	8					
20	24	1 1/2	7	8					
22	24	1 1/2	7 1/2	9					
24	24	1 1/2	7 1/2	9					

NOTA:

1 Para los tamaños de 1" hasta 3", se usarán bridas de orificio de 300 LB.

TABLA PARA PERNOS EN BRIDAS DE ORIFICIO DE 600, 900 Y 1500 LB

TAMAÑO NOMINAL DE LA TUBERÍA	PERNOS DE LAS BRIDAS		LONGITUD DEL ESPARRAGO PARA EL ORIFICIO DE 600 LB		TAMAÑO NOMINAL DE LA TUBERÍA	PERNOS DE LAS BRIDAS		LONGITUD DEL ESPARRAGO PARA EL ORIFICIO DE 1500 LB	
	CANTIDAD	TAMAÑO	RF	RTJ		CANTIDAD	TAMAÑO	RF	RTJ
NOTA: 1					NOTA: 3				
4	8	7/8	5 3/4	6 1/4	1	4	7/8	5 1/2	5 3/4
5	8	1	6 1/4	7	1 1/4	4	3/8	5 1/2	5 3/4
6	12	1	6 3/4	7 1/4	1 1/2	4	1	5 1/2	6
8	12	1 1/8	7 3/8	8 1/4	2	8	7/8	5 3/4	6 1/4
10	16	1 1/4	8 1/4	9	2 1/2	8	1	6 1/4	6 3/4
12	20	1 1/2	9	9 1/4	3	8	1 1/4	7	7 3/8
14	20	1 3/8	9 1/2	9 3/4	4	8	1 1/2	7 3/4	8 1/4
16	20	1 1/2	10	10 1/2	5	8	1 1/2	9 3/4	10 1/4
18	20	1 3/4	11	11 1/4	6	12	1 3/8	10 1/4	11
20	24	1 3/4	11 3/4	12	8	12	1 3/8	11 1/2	12 1/2
22	24	1 3/4	12 1/2	13	10	12	1 3/4	13 1/4	14 1/4
24	24	1 3/4	13 1/4	13 1/2	12	16	2	14 3/4	16
NOTA: 2			ORIFICIO DE 900 LB						
3	8	7/8	5 3/4	6 1/4					
4	8	1 1/8	7	7 1/4					
5	8	1 1/4	7 1/2	8					
6	12	1 1/8	7 5/8	8 3/4					
8	12	1 3/8	9	9 1/4					
10	16	1 3/8	9 1/4	9 3/4					
12	20	1 3/4	10	10 3/4					

NOTAS:
 1 Se usará para los tamaños de 1" hasta 3" bridas de orificio de 300 LB.
 2 Se usará para los tamaños de 1" hasta 2 1/2" bridas de orificio de 1500 LB.
 3 Se pueden obtener también bridas de orificio de 2500 LB.

DIÁMETROS INTERIORES Y EXTERIORES DE LAS TUBERÍAS Y MAQUINADOS DEL DIÁMETRO INTERIOR DE LAS BRIDAS

Tam. nom. tubo	Diám. exterior	Paredes delgadas*	Cédula 20	Cédula 30	Pared estándar	Cédula 40	Cédula 60	Extra-fuerte	Cédula 80	Cédula 100	Cédula 120	Cédula 140	Cédula 160	Doble extra-fuerte
1 1/2	0 840	674	0 622	0 622	...	0 546	0 546	0 464	0 252
	1 050	884	0 824	0 824	...	0 742	0 742	0 612	0 434
	1 315	1 097	1 049	1 049	...	0 957	0 957	0 815	0 599
1 1/2	1 660	1 442	1 380	1 380	...	1 278	1 278	1 160	0 896
	1 900	1 682	1 610	1 610	...	1 500	1 500	1 338	1 100
2 1/2	2 375	2 157	2 067	2 067	...	1 939	1 939	1 687	1 503
	2 875	2 635	2 469	2 469	...	2 323	2 323	2 125	1 771
3 1/2	3 500	3 260	3 068	3 068	...	2 900	2 900	2 624	2 300
	4 000	3 760	3 548	3 548	...	3 364	3 364	2 728
4	4 500	4 260	4 026	4 026	...	3 826	3 826	...	3 624	...	3 438	3 152
	5 563	5 295	5 047	5 047	...	4 813	4 813	...	4 563	...	4 313	4 063
	6 625	6 357	6 065	6 065	...	5 761	5 761	...	5 501	...	5 187	4 897
	8 625	8 329	8 125	8 071	7 981	7 981	7 813	7 625	7 825	7 437	7 187	7 001	6 813	6 875
10	10 750	10 420	10 250	10 138	10 020	10 020	9 750	9 750	9 562	9 312	9 062	8 750	8 500	8 750
	12 750	12 390	12 250	12 090	12 000	11 938	11 626	11 750	11 374	11 062	10 750	10 500	10 126	10 750
	14 000	13 500	13 376	13 250	13 250	13 124	12 812	13 000	12 500	12 124	11 814	11 500	11 188	...
	16 000	15 500	15 376	15 250	15 250	15 000	14 688	15 000	14 312	13 938	13 564	13 124	12 812	...
18	18 000	17 500	17 376	17 124	17 250	16 876	16 500	17 000	16 124	15 688	15 250	14 876	14 438	...
	20 000	19 500	19 250	19 000	19 250	18 812	18 376	19 000	17 938	17 438	17 000	16 500	16 062	...
	24 000	23 500	23 250	22 876	23 250	22 824	22 062	23 000	21 562	20 938	20 376	19 876	19 312	...
30	30 000	29 376	29 000	28 750	29 250	29 000
	36 000	35 376	35 000	34 750	35 250	34 500	...	35 000
42	42 000	41 250	41 000

NOTA: *Los diámetros de las paredes delgadas son iguales a las del acero inoxidable, Cédula 10s (en los tamaños hasta 12"), y para lo Cédula 10 en los tamaños 14" y mayores.

TABLA COMPARATIVA ENTRE LOS MATERIALES DE JUNTAS Y EMPAQUETADURAS

FABRICANTE	MATERIAL DE JUNTAS					EMPAQUETADURAS				
	424	425	450	4250		105	103	888		
ANCHOR	424	425	450	4250		105	103	888		
BELMONT	590	590	584	6735		30-C	189-C	6504	6106	
CHESTERTON	210	235	270	260		350		318	340	
COLLINS	920		3004			1251	1641		47-G	
DURABLA	✓									
JOHN CRANE	334		891	2112		800	804-D	896	1810	
GARLOCK	7735	900	7228	7705		150	176	230	237	
GREENE, TWEED	2900	2905	2910	2970		2206	1130			
HERCULES	565		562	570		101	127	191	138	
JOHNS MANVILLE	60	61	76	84		166	731	2018	18	
RAYBESTOS MANHATTAN	670	501	K-68	1307		121-C	376-C	380		
SOUTHEASTERN PRODUCTS	300		240	400		151-RB		845	168	
STERLING	415	417								

NOTA: Algunos de estos materiales de juntas se pueden obtener sin grafito o con él en uno o ambos caras. Para mayor información se hará referencia a los catálogos de los proveedores.

GRUAS ESTANDAR DE ORUGA, LOCOMOTORA Y CAMION EN LOS EE.UU.

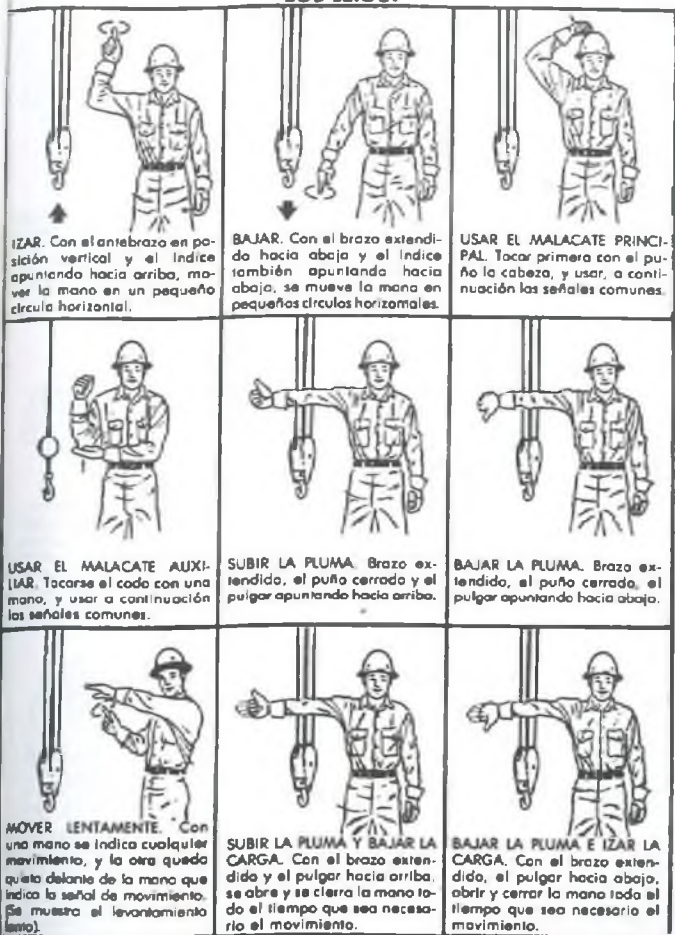

Fig. 1 SEÑALES MANUALES ESTANDAR PARA CONTROLAR LAS OPERACIONES DE LAS GRUAS

Tomado del Crawler, Locomotive and Truck Cranes, B30-5-1968, con autorización de la American Society of Mechanical Engineers, Nueva York, N.Y. 10017

**GRUAS ESTANDAR DE ORUGA, LOCOMOTORA Y CAMION EN L
EE. UU.**









 <p>GIRAR. Con el brazo extendido, indíquese con el Índice las direcciones de giro de la pluma.</p>	 <p>PARAR (ALTO). Con el brazo extendido y la palma hacia abajo, manténgase una posición rígida.</p>	 <p>PARAR (ALTO) DE EMERGENCIA. Con el brazo extendido la palma hacia abajo, muévase rápidamente la mano hacia la derecha y la izquierda.</p>
 <p>AVANZAR. Con el brazo extendido hacia adelante, la mano ligeramente levantada y hacienda como si se empujara, indicando la dirección del avance.</p>	 <p>ASEGURARLO TODO. Se juntan las manos al frente.</p>	 <p>AVANZAR. (Ambas orugas). Se colocan ambas puños frente con un movimiento circular, indicando la dirección del movimiento, (hacia adelante o hacia atrás. (Sólo para las grúas de oruga).</p>
 <p>AVANZAR. (Una sola oruga). Indique que la oruga de un lado permanece inmóvil, levantando el puño correspondiente e indique que la oruga del lado opuesto debe moverse, haciendo un movimiento giratorio vertical del otro puño, colocado al frente. (Sólo para grúas de oruga).</p>	 <p>EXTENDER LA PLUMA. (Plumas telescópicas). Ambos puños al frente con los pulgares hacia afuera.</p>	 <p>REPARAR LA PLUMA. (Plumas telescópicas). Ambos puños al frente con los pulgares hacia adentro.</p>

Fig. 2 SEÑALES MANUALES ESTANDAR PARA CONTROLAR LAS OPERACIONES DE LAS GRUAS

Tomado del Crawler, Locomotive and Truck Cranes, E30-5-1968, con autorización de la "American Society of Mechanical Engineers", Nueva York, N.Y. 10017.

GRUAS VIAJERAS Y GRUAS PORTAL

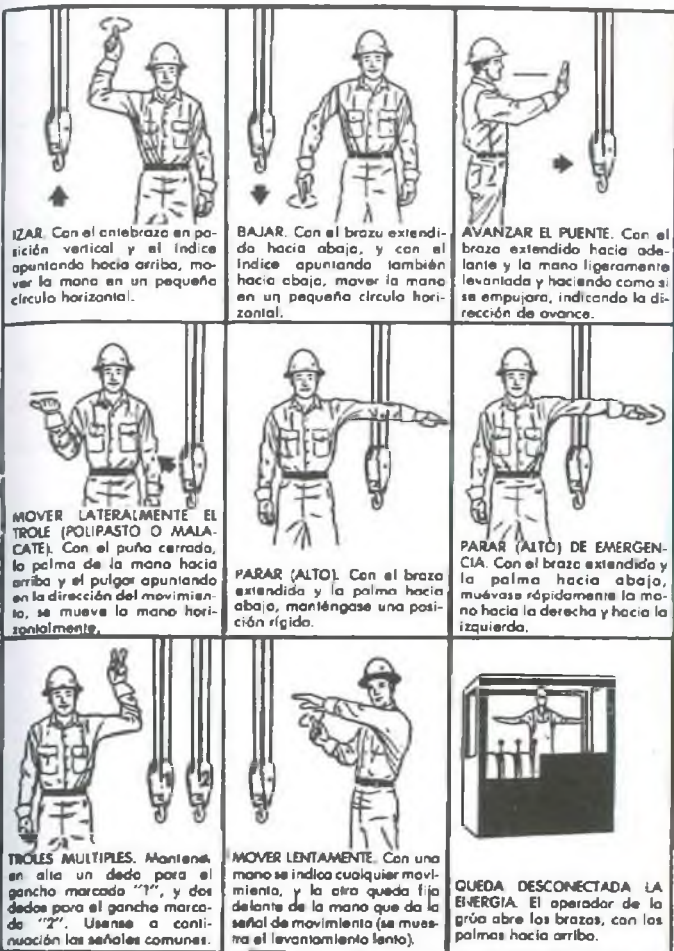

IZAR. Con el antebrazo en posición vertical y el índice apuntando hacia arriba, mover la mano en un pequeño círculo horizontal.

BAJAR. Con el brazo extendida hacia abajo, y con el índice apuntando también hacia abajo, mover la mano en un pequeño círculo horizontal.

AVANZAR EL PUENTE. Con el brazo extendido hacia adelante y la mano ligeramente levantada y haciendo como si se empujara, indicando la dirección de avance.

MOVER LATERALMENTE EL TROLE (POLIPASTO O MALACATE). Con el puño cerrado, la palma de la mano hacia arriba y el pulgar apuntando en la dirección del movimiento, se mueve la mano horizontalmente.

PARAR (ALTO). Con el brazo extendida y la palma hacia abajo, manténgase una posición rígida.

PARAR (ALTO) DE EMERGENCIA. Con el brazo extendido y la palma hacia abajo, muévase rápidamente la mano hacia la derecha y hacia la izquierda.

TROLES MÚLTIPLES. Mantenga en alta un dedo para el gancho marcado "1", y dos dedos para el gancho marcado "2". Usense a continuación las señales comunes.

MOVER LENTAMENTE. Con una mano se indica cualquier movimiento, y la otra queda fija delante de la mano que da la señal de movimiento (se muestra el levantamiento lento).

QUEDA DESCONECTADA LA ENERGÍA. El operador de la grúa abre los brazos, con las palmas hacia arriba.

FIG. 3 SEÑALES MANUALES ESTÁNDAR PARA CONTROLAR LAS GRUAS VIAJERAS Y GRUAS PORTAL

Tomado del Overhead and Gantry Cranes. B30-2-1967, con autorización de la American Society of Mechanical Engineers, Nueva York, N.Y. 10017.

INFORMACION UTIL

EXPANSION TOTAL POR 100 PIES

1. En las tuberías de acero es igual a la temperatura final menos la temperatura inicial, multiplicada por 0.00804.
2. En las tuberías de cobre y latón es igual a la temperatura final menos la temperatura inicial, multiplicada por 0.0114.
3. Para longitudes menores de 100 pies, se corre el punto decimal dos lugares a la izquierda. Ejemplos: 72 pies es igual a 0.72; 172 pies es igual a 1.72 X los valores anotados para 100 pies.

DOBLECES EN LAS TUBERIAS

1. Se acostumbra el radio mínimo como 6 veces el diámetro de la tubería.
2. La longitud de tubería requerida para una curva es igual al radio multiplicado por los grados y por 0.01745.

EL CIRCULO

1. La circunferencia es igual al radio multiplicado por 3.1416.
2. El diámetro es igual a la circunferencia multiplicada por 0.31831.
3. La longitud del arco es igual al radio multiplicado por los grados y por 0.01745.
4. Los grados de un arco son iguales a la longitud dividida entre el radio multiplicado por 0.01745.
5. El radio del arco es igual a la longitud dividida entre los grados multiplicados por 0.01745.

CENTESIMOS DE PIE

1. Para convertir centésimos de pie a pulgadas, multiplíquese por 12.
2. Para convertir pulgadas a centésimos de pie, multiplíquese por 0.0833.

PARA CONVERTIR PULGADAS Y PIES A MILIMETROS

1"	25.4	7"	177.8	1'	304.8	7'	2133.6
2"	50.8	8"	203.2	2'	609.6	8'	2438.4
3"	76.2	9"	228.6	3'	914.4	9'	2743.2
4"	101.6	10"	254.0	4'	1219.2	10'	3048.0
5"	127.0	11"	279.4	5'	1524.0	11'	3352.8
6"	152.4	12"	304.8	6'	1828.8	12'	3657.6

**CORRASE EL PUNTO DECIMAL HACIA LA IZQUIERDA:
UN ESPACIO PARA LOS CENTIMETROS
DOS ESPACIOS PARA LOS DECIMETROS
TRES ESPACIOS PARA LOS METROS**

VEASE LA PAGINA 126 PARA CONVERTIR FRACCIONES A MILIMETROS

CONSTANTES DE CONVERSION

PARA CONVERTIR	A	MULTIPLIQUESE POR
Pulgadas	Pies	0.0833
Pulgadas	Milímetros	25.4
Pies	Pulgadas	12
Pies	Yardas	0.3333
Yardas	Pies	3
Pulg. ²	Pies ²	0.00694
Pies ²	Pulg. ²	144
Pies ²	Yardas ²	0.11111
Yardas ²	Pies ²	9
Pulg. ²	Pies ³	0.00058
Pies ³	Pulg. ³	1728
Pies ³	Yardas ³	0.03703
Yardas ³	Pies ³	27
Pulg. ³	Galones	0.00433
Pies cúbicos	Galones	7.48
Galones	Pulg. ³	231
Galones	Pies ³	0.1337
Galones	Libras de agua	8.33
Libras de agua	Galones	0.12004
Onza	Libras	0.0625
Libras	Onzas	16
Pulg. de agua	Libras por pulg. ²	0.0361
Pulg. de agua	Pulg. de mercurio	0.0735
Pulg. de agua	Onzas por pulg. ²	0.578
Pulg. de agua	Libras por pie ²	5.2
Pulg. de mercurio	Pulg. de agua	13.6
Pulg. de mercurio	Pies de agua	1.1333
Pulg. de mercurio	Libras por pulg. ²	0.4914
Onzas por pulg. ²	Pulg. de mercurio	0.127
Onzas por pulg. ²	Pulg. de agua	1.733
Libras por pulg. ²	Pulg. de agua	27.72
Libras por pulg. ²	Pies de agua	2.310
Libras por pulg. ²	Pulg. de mercurio	2.04
Libras por pulg. ²	Atmósferas	0.0681
Pies de agua	Libras por pulg. ²	0.434
Pies de agua	Libras por pie ²	62.5
Pies de agua	Pulg. de mercurio	0.8824
Atmósferas	Libras por pulg. ²	14.696
Atmósferas	Pulg. de mercurio	29.92
Atmósferas	Pies de agua	34
Toneladas largas	Libras	2240
Toneladas cortas	Libras	2000
Toneladas cortas	Toneladas largas	0.89285

EQUIVALENTES DECIMALES

Fracción			Deci- mal	Mili- metros	Fracción			Deci- mal	Mili- metros
		1/64	.01563	0.397			33/64	.51563	13.097
	1/32		.03125	0.794		17/32		.53125	13.494
		3/64	.04688	1.191			35/64	.54688	13.891
1/16			.0625	1.588	9/16			.5625	14.288
		5/64	.07813	1.984			37/64	.57813	14.684
	3/32		.09375	2.381		19/32		.59375	15.081
		7/64	.10938	2.778			39/64	.60938	15.478
1/8			.125	3.175	5/8			.625	15.875
		9/64	.14063	3.572			41/64	.64063	16.272
	5/32		.15625	3.969		21/32		.65625	16.669
		11/64	.17188	4.366			43/64	.67188	17.066
3/16			.1875	4.763	11/16			.6875	17.463
		13/64	.20313	5.159			45/64	.70313	17.859
	7/32		.21875	5.556		23/32		.71875	18.256
		15/64	.23438	5.953			47/64	.73438	18.653
1/4			.250	6.350	3/4			.750	19.050
		17/64	.26563	6.747			49/64	.76563	19.447
	9/32		.28125	7.144		25/32		.78125	19.844
		19/64	.29688	7.541			51/64	.79688	20.241
5/16			.3125	7.938	13/16			.8125	20.638
		21/64	.32813	8.334			53/64	.82813	21.034
	11/32		.34375	8.731		27/32		.84375	21.431
		23/64	.35938	9.128			55/64	.85938	21.828
3/8			.375	9.525	7/8			.875	22.225
		25/64	.39063	9.922			57/64	.89063	22.622
	13/32		.40625	10.319		29/32		.90625	23.019
		27/64	.42188	10.716			59/64	.92188	23.416
7/16			.4375	11.113	15/16			.9375	23.813
		29/64	.45313	11.509			61/64	.95313	24.209
	15/32		.46875	11.906		31/32		.96875	24.606
		31/64	.48438	12.303			63/64	.98438	25.003
1/2			.500	12.700	1			1.00000	25.400

CABLES DE ALAMBRES DE ACERO

Carga segura en libras para cables nuevos de acero
6 cabos de 7 alambres, centro de cáñamo

TAMAÑO EN PULGAS	CARGA SEGURA EN LIBRAS	TAMAÑO EN PULGAS	CARGA SEGURA EN LIBRAS	TAMAÑO EN PULGAS	CARGA SEGURA EN LIBRAS
1/4	940	9/16	4,500	1-1/8	17,400
5/16	1,400	5/8	5,500	1-1/4	21,200
3/8	2,000	3/4	7,900	1-3/8	25,400
7/16	2,700	7/8	10,700	1-1/2	30,000
1/2	3,600	1	13,900		

**CUANDO SE TRATE DE CABLES GALVANIZADOS,
SE DEDUCIRA UN 10% DE LA RESISTENCIA INDICADA**

CUERDA DE MANILA					
Carga segura para cable nuevo de manila — de 3 cabos Factor de seguridad — 7					
TAMAÑO EN PULGAS	CARGA SEGURA EN LIBRAS	TAMAÑO EN PULGAS	CARGA SEGURA EN LIBRAS	TAMAÑO EN PULGAS	CARGA SEGURA EN LIBRAS
1/4	85	3/4	780	1-1/4	1,900
3/8	185	13/16	920	1-1/2	2,640
1/2	360	1	1,280	1-13/16	3,700
				2	4,400

REGLAS PRACTICAS EMPIRICAS

Gancho de ojo abierto La carga segura en toneladas es igual al diámetro del ojo expresado en pulgadas y elevado al cuadrado.
Gancho de 2", $2 \times 2 = 4$ tons.

Grillete El cargo seguro en toneladas es igual al diámetro del pasador expresado en cuartos de pulgada (1/4") elevado al cuadrado y dividido entre tres (3).

$$\text{Diámetro de } 1/2 = 2 \text{ cuartos}$$

$$\frac{2 \times 2}{3} = 1\frac{1}{3} \text{ tons. o } 2,667 \text{ libras}$$

Cadenas El cargo seguro en toneladas es igual a seis (6) veces el diámetro del redondo de la cadena expresado en pulgadas y elevado al cuadrado.

$$\text{Diámetro del redondo de la cadena } 1/2"$$

$$1/2 \times 1/2 \times 6 = 1\frac{1}{2} \text{ tons. o } 3,000 \text{ lbs}$$

DECIMALES DE PIE

Pulg.	0"	1"	2"	3"	4"	5"	6"	7"	8"	9"	10"	11"
0	0	.0833	.1667	.2500	.3333	.4167	.5000	.5833	.6667	.7500	.8333	.9167
1/16	.0052	.0885	.1719	.2552	.3385	.4219	.5052	.5885	.6719	.7552	.8385	.9219
1/8	.0104	.0938	.1771	.2604	.3438	.4271	.5104	.5938	.6771	.7604	.8438	.9271
3/16	.0156	.0990	.1823	.2656	.3490	.4323	.5156	.5990	.6823	.7656	.8490	.9323
1/4	.0208	.1042	.1875	.2708	.3542	.4375	.5208	.6042	.6875	.7708	.8542	.9375
5/16	.0260	.1094	.1927	.2760	.3594	.4427	.5260	.6094	.6927	.7760	.8594	.9427
3/8	.0313	.1146	.1979	.2812	.3646	.4479	.5313	.6146	.6979	.7813	.8646	.9479
7/16	.0365	.1198	.2031	.2865	.3698	.4531	.5365	.6198	.7031	.7865	.8698	.9531
1/2	.0417	.1250	.2083	.2917	.3750	.4583	.5417	.6250	.7083	.7917	.8750	.9583
9/16	.0469	.1302	.2135	.2969	.3802	.4635	.5469	.6302	.7135	.7969	.8802	.9635
5/8	.0521	.1354	.2188	.3021	.3854	.4688	.5521	.6354	.7188	.8021	.8854	.9688
11/16	.0573	.1406	.2240	.3073	.3906	.4740	.5573	.6406	.7240	.8073	.8906	.9740
3/4	.0625	.1458	.2292	.3125	.3958	.4792	.5625	.6458	.7292	.8125	.8958	.9792
13/16	.0677	.1510	.2344	.3177	.4010	.4844	.5677	.6510	.7344	.8177	.9010	.9844
7/8	.0729	.1563	.2396	.3229	.4063	.4896	.5729	.6563	.7396	.8229	.9063	.9896
15/16	.0781	.1615	.2448	.3281	.4115	.4948	.5781	.6615	.7448	.8281	.9115	.9948
1	.0833	.1667	.2500	.3333	.4167	.5000	.5833	.6667	.7500	.8333	.9167	1.0000

128

MINUTOS CONVERTIDOS A DECIMALES DE GRADO



MIN	GRAD	MIN	GRAD	MIN	GRAD	MIN	GRAD	MIN	GRAD	MIN	GRAD
1	.0166	11	.1833	21	.3500	31	.5166	41	.6833	51	.8500
2	.0333	12	.2000	22	.3666	32	.5333	42	.7000	52	.8666
3	.0500	13	.2166	23	.3833	33	.5500	43	.7166	53	.8833
4	.0666	14	.2333	24	.4000	34	.5666	44	.7333	54	.9000
5	.0833	15	.2500	25	.4166	35	.5833	45	.7500	55	.9166
6	.1000	16	.2666	26	.4333	36	.6000	46	.7666	56	.9333
7	.1166	17	.2833	27	.4500	37	.6166	47	.7833	57	.9500
8	.1333	18	.3000	28	.4666	38	.6333	48	.8000	58	.9666
9	.1500	19	.3166	29	.4833	39	.6500	49	.8166	59	.9833
10	.1666	20	.3333	30	.5000	40	.6666	50	.8333	60	1.0000

129

FORMULAS PARA ENCONTRAR LAS FUNCIONES DE LOS ANGULOS

Cateto opuesto Hipotenusa	= SENO
Cateto adyacente Hipotenusa	= COSENO
Cateto opuesto Cateto adyacente	= TANGENTE
Cateto adyacente Cateto opuesto	= COTANGENTE
Hipotenusa Cateto adyacente	= SECANTE
Hipotenusa Cateto opuesto	= COSECANTE

FORMULAS PARA HALLAR LA LONGITUD DE LOS LADOS DE UN TRIANGULO RECTANGULO CUAN- DO SE CONOCE UN ANGULO Y UN LADO

Longitud de cateto opuesto	$\left\{ \begin{array}{l} \text{Hipotenusa} \times \text{seno} \\ \text{Hipotenusa} \div \text{cosecante} \\ \text{Cateto adyacente} \times \text{tangente} \\ \text{Cateto adyacente} \div \text{cotangente} \end{array} \right.$
Longitud del cateto adyacente	$\left\{ \begin{array}{l} \text{Hipotenusa} \times \text{coseno} \\ \text{Hipotenusa} \div \text{secante} \\ \text{Cateto opuesto} \times \text{cotangente} \\ \text{Cateto opuesto} \div \text{tangente} \end{array} \right.$
Longitud de la hipotenusa	$\left\{ \begin{array}{l} \text{Cateto opuesto} \div \text{cosecante} \\ \text{Cateto opuesto} \div \text{seno} \\ \text{Cateto adyacente} \times \text{secante} \\ \text{Cateto adyacente} \div \text{coseno} \end{array} \right.$

TABLAS TRIGONOMETRICAS
0°

M	Sen.	Cos.	Tan.	Col.	Sec.	Csc.	M
0	0.0000	1.0000	0.0000	infinic	0.0000	infinic	00
1	0.0017	0.9999	0.0034	34.77	0.0000	3177.77	01
2	0.0034	0.9998	0.0069	69.54	0.0000	6355.54	02
3	0.0051	0.9997	0.0103	103.61	0.0000	9533.61	03
4	0.0068	0.9996	0.0137	137.68	0.0000	12711.68	04
5	0.0085	0.9995	0.0171	171.75	0.0000	15889.75	05
6	0.0102	0.9994	0.0205	205.82	0.0000	19067.82	06
7	0.0119	0.9993	0.0239	239.89	0.0000	22245.89	07
8	0.0136	0.9992	0.0273	273.96	0.0000	25423.96	08
9	0.0153	0.9991	0.0307	308.03	0.0000	28602.03	09
10	0.0170	0.9990	0.0341	342.10	0.0000	31780.10	10
11	0.0187	0.9989	0.0375	376.17	0.0000	34958.17	11
12	0.0204	0.9988	0.0409	410.24	0.0000	38136.24	12
13	0.0221	0.9987	0.0443	444.31	0.0000	41314.31	13
14	0.0238	0.9986	0.0477	478.38	0.0000	44492.38	14
15	0.0255	0.9985	0.0511	512.45	0.0000	47670.45	15
16	0.0272	0.9984	0.0545	546.52	0.0000	50848.52	16
17	0.0289	0.9983	0.0579	580.59	0.0000	54026.59	17
18	0.0306	0.9982	0.0613	614.66	0.0000	57204.66	18
19	0.0323	0.9981	0.0647	648.73	0.0000	60382.73	19
20	0.0340	0.9980	0.0681	682.80	0.0000	63560.80	20
21	0.0357	0.9979	0.0715	716.87	0.0000	66738.87	21
22	0.0374	0.9978	0.0749	750.94	0.0000	69916.94	22
23	0.0391	0.9977	0.0783	785.01	0.0000	73095.01	23
24	0.0408	0.9976	0.0817	819.08	0.0000	76273.08	24
25	0.0425	0.9975	0.0851	853.15	0.0000	79451.15	25
26	0.0442	0.9974	0.0885	887.22	0.0000	82629.22	26
27	0.0459	0.9973	0.0919	921.29	0.0000	85807.29	27
28	0.0476	0.9972	0.0953	955.36	0.0000	88985.36	28
29	0.0493	0.9971	0.0987	989.43	0.0000	92163.43	29
30	0.0510	0.9970	0.1021	1023.50	0.0000	95341.50	30
31	0.0527	0.9969	0.1055	1057.57	0.0000	98519.57	31
32	0.0544	0.9968	0.1089	1091.64	0.0000	101697.64	32
33	0.0561	0.9967	0.1123	1125.71	0.0000	104875.71	33
34	0.0578	0.9966	0.1157	1159.78	0.0000	108053.78	34
35	0.0595	0.9965	0.1191	1193.85	0.0000	111231.85	35
36	0.0612	0.9964	0.1225	1227.92	0.0000	114409.92	36
37	0.0629	0.9963	0.1259	1261.99	0.0000	117587.99	37
38	0.0646	0.9962	0.1293	1296.06	0.0000	120766.06	38
39	0.0663	0.9961	0.1327	1330.13	0.0000	123944.13	39
40	0.0680	0.9960	0.1361	1364.20	0.0000	127122.20	40
41	0.0697	0.9959	0.1395	1398.27	0.0000	130300.27	41
42	0.0714	0.9958	0.1429	1432.34	0.0000	133478.34	42
43	0.0731	0.9957	0.1463	1466.41	0.0000	136656.41	43
44	0.0748	0.9956	0.1497	1500.48	0.0000	139834.48	44
45	0.0765	0.9955	0.1531	1534.55	0.0000	143012.55	45
46	0.0782	0.9954	0.1565	1568.62	0.0000	146190.62	46
47	0.0799	0.9953	0.1599	1602.69	0.0000	149368.69	47
48	0.0816	0.9952	0.1633	1636.76	0.0000	152546.76	48
49	0.0833	0.9951	0.1667	1670.83	0.0000	155724.83	49
50	0.0850	0.9950	0.1701	1704.90	0.0000	158902.90	50
51	0.0867	0.9949	0.1735	1738.97	0.0000	162080.97	51
52	0.0884	0.9948	0.1769	1773.04	0.0000	165259.04	52
53	0.0901	0.9947	0.1803	1807.11	0.0000	168437.11	53
54	0.0918	0.9946	0.1837	1841.18	0.0000	171615.18	54
55	0.0935	0.9945	0.1871	1875.25	0.0000	174793.25	55
56	0.0952	0.9944	0.1905	1909.32	0.0000	177971.32	56
57	0.0969	0.9943	0.1939	1943.39	0.0000	181149.39	57
58	0.0986	0.9942	0.1973	1977.46	0.0000	184327.46	58
59	0.1003	0.9941	0.2007	2011.53	0.0000	187505.53	59
60	0.1020	0.9940	0.2041	2045.60	0.0000	190683.60	60

89°
120

1°

M	Sen.	Cos.	Tan.	Col.	Sec.	Csc.	M
0	0.0175	0.9985	0.0175	57.280	1.0001	57.299	60
1	0.0176	0.9984	0.0176	56.350	0.0001	56.359	59
2	0.0177	0.9983	0.0177	55.421	0.0001	55.430	58
3	0.0178	0.9982	0.0178	54.491	0.0001	54.500	57
4	0.0179	0.9981	0.0179	53.562	0.0001	53.570	56
5	0.0180	0.9980	0.0180	52.632	0.0001	52.640	55
6	0.0181	0.9979	0.0181	51.703	0.0001	51.710	54
7	0.0182	0.9978	0.0182	50.773	0.0001	50.780	53
8	0.0183	0.9977	0.0183	49.844	0.0001	49.850	52
9	0.0184	0.9976	0.0184	48.914	0.0001	48.920	51
10	0.0185	0.9975	0.0185	47.985	0.0001	47.990	50
11	0.0186	0.9974	0.0186	47.055	0.0001	47.060	49
12	0.0187	0.9973	0.0187	46.126	0.0001	46.130	48
13	0.0188	0.9972	0.0188	45.196	0.0001	45.200	47
14	0.0189	0.9971	0.0189	44.267	0.0001	44.270	46
15	0.0190	0.9970	0.0190	43.337	0.0001	43.340	45
16	0.0191	0.9969	0.0191	42.408	0.0001	42.410	44
17	0.0192	0.9968	0.0192	41.478	0.0001	41.480	43
18	0.0193	0.9967	0.0193	40.549	0.0001	40.550	42
19	0.0194	0.9966	0.0194	39.619	0.0001	39.620	41
20	0.0195	0.9965	0.0195	38.690	0.0001	38.690	40
21	0.0196	0.9964	0.0196	37.760	0.0001	37.760	39
22	0.0197	0.9963	0.0197	36.831	0.0001	36.830	38
23	0.0198	0.9962	0.0198	35.901	0.0001	35.900	37
24	0.0199	0.9961	0.0199	34.972	0.0001	34.970	36
25	0.0200	0.9960	0.0200	34.042	0.0001	34.040	35
26	0.0201	0.9959	0.0201	33.113	0.0001	33.110	34
27	0.0202	0.9958	0.0202	32.183	0.0001	32.180	33
28	0.0203	0.9957	0.0203	31.254	0.0001	31.250	32
29	0.0204	0.9956	0.0204	30.324	0.0001	30.320	31
30	0.0205	0.9955	0.0205	29.395	0.0001	29.390	30
31	0.0206	0.9954	0.0206	28.465	0.0001	28.460	29
32	0.0207	0.9953	0.0207	27.536	0.0001	27.530	28
33	0.0208	0.9952	0.0208	26.606	0.0001	26.600	27
34	0.0209	0.9951	0.0209	25.677	0.0001	25.670	26
35	0.0210	0.9950	0.0210	24.747	0.0001	24.740	25
36	0.0211	0.9949	0.0211	23.818	0.0001	23.810	24
37	0.0212	0.9948	0.0212	22.888	0.0001	22.880	23
38	0.0213	0.9947	0.0213	21.959	0.0001	21.950	22
39	0.0214	0.9946	0.0214	21.029	0.0001	21.020	21
40	0.0215	0.9945	0.0215	20.100	0.0001	20.090	20
41	0.0216	0.9944	0.0216	19.170	0.0001	19.160	19
42	0.0217	0.9943	0.0217	18.241	0.0001	18.230	18
43	0.0218	0.9942	0.0218	17.311	0.0001	17.300	17
44	0.0219	0.9941	0.0219	16.382	0.0001	16.370	16
45	0.0220	0.9940	0.0220	15.452	0.0001	15.440	15
46	0.0221	0.9939	0.0221	14.523	0.0001	14.510	14
47	0.0222	0.9938	0.0222	13.593	0.0001	13.580	13
48	0.0223	0.9937	0.0223	12.664	0.0001	12.650	12
49	0.0224	0.9936	0.0224	11.734	0.0001	11.720	11
50	0.0225	0.9935	0.0225	10.805	0.0001	10.790	10
51	0.0226	0.9934	0.0226	9.875	0.0001	9.860	9
52	0.0227	0.9933	0.0227	8.946	0.0001	8.930	8
53	0.0228	0.9932	0.0228	8.016	0.0001	8.000	7
54	0.0229	0.9931	0.0229	7.087	0.0001	7.070	6
55	0.0230	0.9930	0.0230	6.157	0.0001	6.140	5
56	0.0231	0.9929	0.0231	5.228	0.0001	5.210	4
57	0.0232	0.9928	0.0232	4.298	0.0001	4.280	3
58	0.0233	0.9927	0.0233	3.369	0.0001	3.350	2
59	0.0234	0.9926	0.0234	2.439	0.0001	2.420	1
60	0.0235	0.9925	0.0235	1.510	0.0001	1.490	0

88°
131

M	Sen	Cos	Ton	Sec	Csk	M
0	03490	59539	03492	10006	28 554	60
1	03518	59938	03521	00006	28 417	59
2	03548	59937	03550	00006	28 184	58
3	03577	59936	03579	00006	27 955	57
4	03606	59935	03608	00006	27 730	56
5	03635	59934	03638	00007	27 508	55
6	03664	59933	03667	00007	27 294	54
7	03693	59932	03696	00007	27 084	53
8	03722	59931	03725	00007	26 885	52
9	03751	59930	03754	00007	26 695	51
10	03781	59928	03783	00007	26 520	50
11	03810	59927	03812	00007	26 349	49
12	03839	59926	03842	00007	26 193	48
13	03868	59925	03871	00007	26 054	47
14	03897	59924	03900	00008	25 941	46
15	03926	59923	03929	00008	25 864	45
16	03955	59922	03958	00008	25 820	44
17	03984	59921	03987	00008	25 804	43
18	04013	59920	04016	00008	25 818	42
19	04042	59919	04045	00008	25 859	41
20	04071	59918	04074	00008	25 924	40
21	04100	59915	04103	00008	26 008	39
22	04129	59915	04132	00008	26 106	38
23	04158	59913	04161	00009	26 017	37
24	04187	59912	04190	00009	26 049	36
25	04216	59911	04224	00009	26 080	35
26	04245	59910	04249	00009	26 116	34
27	04274	59908	04279	00009	26 153	33
28	04304	59907	04309	00009	26 193	32
29	04333	59906	04337	00009	26 235	31
30	04362	59905	04366	00009	26 279	30
31	04391	59903	04394	00010	26 324	29
32	04420	59902	04424	00010	26 371	28
33	04449	59901	04453	00010	26 417	27
34	04478	59900	04483	00010	26 465	26
35	04507	59898	04512	00010	26 516	25
36	04536	59897	04541	00010	26 569	24
37	04565	59895	04570	00011	26 624	23
38	04594	59893	04599	00011	26 681	22
39	04623	59893	04628	00011	26 740	21
40	04652	59892	04657	00011	26 800	20
41	04681	59891	04686	00011	26 861	19
42	04710	59889	04715	00011	26 924	18
43	04739	59888	04744	00011	26 988	17
44	04768	59886	04773	00011	27 054	16
45	04797	59885	04802	00011	27 121	15
46	04826	59883	04831	00011	27 189	14
47	04855	59882	04860	00012	27 258	13
48	04884	59881	04889	00012	27 328	12
49	04913	59879	04912	00012	27 399	11
50	04942	59878	04941	00012	27 471	10
51	04971	59876	04970	00012	27 544	9
52	05000	59875	05007	00012	27 618	8
53	05029	59873	05037	00013	27 694	7
54	05058	59871	05067	00013	27 771	6
55	05087	59869	05097	00013	27 850	5
56	05117	59867	05124	00013	27 931	4
57	05146	59866	05153	00013	28 013	3
58	05175	59864	05182	00013	28 096	2
59	05204	59864	05211	00014	28 181	1
60	05234	59863	05241	19 081	19 107	0

M	Sen	Cos	Ton	Col	Sec	Csk	M
0	05234	59863	05241	19 081	1 004 4	19 107	60
1	05263	59861	05270	18 975	0 004 4	18 992	59
2	05292	59860	05299	18 871	0 004 4	18 887	58
3	05321	59858	05338	18 768	0 004 4	18 794	57
4	05350	59857	05357	18 665	0 004 4	18 697	56
5	05379	59855	05387	18 564	0 004 4	18 603	55
6	05408	59854	05417	18 464	0 004 4	18 511	54
7	05437	59852	05447	18 364	0 004 4	18 421	53
8	05466	59850	05476	18 266	0 004 4	18 333	52
9	05495	59849	05505	18 171	0 004 4	18 246	51
10	05524	59847	05532	18 075	0 004 4	18 160	50
11	05553	59846	05562	17 980	0 004 4	18 076	49
12	05582	59844	05591	17 886	0 004 4	17 994	48
13	05611	59842	05640	17 793	0 004 4	17 913	47
14	05640	59841	05669	17 701	0 004 4	17 834	46
15	05669	59839	05698	17 610	0 004 4	17 756	45
16	05698	59837	05727	17 520	0 004 4	17 680	44
17	05727	59836	05756	17 431	0 004 4	17 605	43
18	05756	59834	05785	17 342	0 004 4	17 531	42
19	05785	59832	05814	17 254	0 004 4	17 458	41
20	05814	59831	05843	17 167	0 004 4	17 386	40
21	05843	59829	05872	17 084	0 004 4	17 315	39
22	05872	59827	05901	17 003	0 004 4	17 245	38
23	05901	59826	05930	16 923	0 004 4	17 176	37
24	05930	59824	05959	16 844	0 004 4	17 108	36
25	05960	59822	05970	16 766	0 004 4	17 041	35
26	05989	59820	05995	16 689	0 004 4	16 975	34
27	06018	59819	06029	16 613	0 004 4	16 911	33
28	06047	59817	06058	16 537	0 004 4	16 848	32
29	06076	59815	06087	16 462	0 004 4	16 786	31
30	06105	59813	06116	16 387	0 004 4	16 725	30
31	06134	59812	06145	16 312	0 004 4	16 665	29
32	06163	59810	06174	16 237	0 004 4	16 605	28
33	06192	59808	06204	16 163	0 004 4	16 546	27
34	06221	59806	06233	16 093	0 004 4	16 487	26
35	06250	59804	06262	16 024	0 004 4	16 429	25
36	06279	59803	06291	15 959	0 004 4	16 372	24
37	06308	59801	06321	15 894	0 004 4	16 316	23
38	06337	59799	06350	15 829	0 004 4	16 261	22
39	06366	59797	06379	15 766	0 004 4	16 207	21
40	06395	59795	06408	15 705	0 004 4	16 154	20
41	06424	59793	06437	15 645	0 004 4	16 102	19
42	06453	59791	06467	15 586	0 004 4	16 051	18
43	06482	59789	06496	15 528	0 004 4	16 001	17
44	06511	59788	06527	15 471	0 004 4	15 952	16
45	06540	59786	06558	15 416	0 004 4	15 904	15
46	06569	59784	06589	15 362	0 004 4	15 857	14
47	06598	59782	06620	15 309	0 004 4	15 811	13
48	06627	59781	06651	15 257	0 004 4	15 766	12
49	06656	59779	06682	15 206	0 004 4	15 722	11
50	06685	59776	06713	15 156	0 004 4	15 679	10
51	06714	59774	06744	15 107	0 004 4	15 637	9
52	06743	59772	06775	15 059	0 004 4	15 595	8
53	06772	59770	06806	15 012	0 004 4	15 554	7
54	06801	59768	06837	14 966	0 004 4	15 514	6
55	06830	59766	06868	14 921	0 004 4	15 474	5
56	06859	59764	06899	14 877	0 004 4	15 435	4
57	06888	59762	06930	14 834	0 004 4	15 396	3
58	06917	59760	06961	14 792	0 004 4	15 358	2
59	06946	59758	06992	14 751	0 004 4	15 321	1
60	06975	59756	07023	14 711	1 007 4	14 335	0

4°

M	Sen	Cos	Tan	Col	Sec	Csc	M
0	0.6976	0.9174	0.6976	14.301	1.0024	14.331	60
1	0.7005	0.9150	0.7005	14.274	0.0025	14.276	59
2	0.7034	0.9125	0.7034	14.247	0.0051	14.249	58
3	0.7063	0.9100	0.7063	14.221	0.0076	14.223	57
4	0.7092	0.9074	0.7092	14.195	0.0102	14.197	56
5	0.7121	0.9048	0.7121	14.169	0.0128	14.171	55
6	0.7150	0.9022	0.7150	14.143	0.0154	14.145	54
7	0.7179	0.9000	0.7179	14.117	0.0180	14.119	53
8	0.7208	0.8978	0.7208	14.091	0.0206	14.093	52
9	0.7237	0.8956	0.7237	14.065	0.0232	14.067	51
10	0.7266	0.8934	0.7266	14.039	0.0258	14.041	50
11	0.7295	0.8912	0.7295	14.013	0.0284	14.015	49
12	0.7324	0.8890	0.7324	13.987	0.0310	13.989	48
13	0.7353	0.8868	0.7353	13.961	0.0336	13.963	47
14	0.7382	0.8846	0.7382	13.935	0.0362	13.937	46
15	0.7411	0.8824	0.7411	13.909	0.0388	13.911	45
16	0.7440	0.8802	0.7440	13.883	0.0414	13.885	44
17	0.7469	0.8780	0.7469	13.857	0.0440	13.859	43
18	0.7498	0.8758	0.7498	13.831	0.0466	13.833	42
19	0.7527	0.8736	0.7527	13.805	0.0492	13.807	41
20	0.7556	0.8714	0.7556	13.779	0.0518	13.781	40
21	0.7585	0.8692	0.7585	13.753	0.0544	13.755	39
22	0.7614	0.8670	0.7614	13.727	0.0570	13.729	38
23	0.7643	0.8648	0.7643	13.701	0.0596	13.703	37
24	0.7672	0.8626	0.7672	13.675	0.0622	13.677	36
25	0.7701	0.8604	0.7701	13.649	0.0648	13.651	35
26	0.7730	0.8582	0.7730	13.623	0.0674	13.625	34
27	0.7759	0.8560	0.7759	13.597	0.0700	13.599	33
28	0.7788	0.8538	0.7788	13.571	0.0726	13.573	32
29	0.7817	0.8516	0.7817	13.545	0.0752	13.547	31
30	0.7846	0.8494	0.7846	13.519	0.0778	13.521	30
31	0.7875	0.8472	0.7875	13.493	0.0804	13.495	29
32	0.7904	0.8450	0.7904	13.467	0.0830	13.469	28
33	0.7933	0.8428	0.7933	13.441	0.0856	13.443	27
34	0.7962	0.8406	0.7962	13.415	0.0882	13.417	26
35	0.7991	0.8384	0.7991	13.389	0.0908	13.391	25
36	0.8020	0.8362	0.8020	13.363	0.0934	13.365	24
37	0.8049	0.8340	0.8049	13.337	0.0960	13.339	23
38	0.8078	0.8318	0.8078	13.311	0.0986	13.313	22
39	0.8107	0.8296	0.8107	13.285	0.1012	13.287	21
40	0.8136	0.8274	0.8136	13.259	0.1038	13.261	20
41	0.8165	0.8252	0.8165	13.233	0.1064	13.235	19
42	0.8194	0.8230	0.8194	13.207	0.1090	13.209	18
43	0.8223	0.8208	0.8223	13.181	0.1116	13.183	17
44	0.8252	0.8186	0.8252	13.155	0.1142	13.157	16
45	0.8281	0.8164	0.8281	13.129	0.1168	13.131	15
46	0.8310	0.8142	0.8310	13.103	0.1194	13.105	14
47	0.8339	0.8120	0.8339	13.077	0.1220	13.079	13
48	0.8368	0.8098	0.8368	13.051	0.1246	13.053	12
49	0.8397	0.8076	0.8397	13.025	0.1272	13.027	11
50	0.8426	0.8054	0.8426	12.999	0.1298	12.999	10
51	0.8455	0.8032	0.8455	12.973	0.1324	12.975	9
52	0.8484	0.8010	0.8484	12.947	0.1350	12.949	8
53	0.8513	0.7988	0.8513	12.921	0.1376	12.923	7
54	0.8542	0.7966	0.8542	12.895	0.1402	12.897	6
55	0.8571	0.7944	0.8571	12.869	0.1428	12.871	5
56	0.8600	0.7922	0.8600	12.843	0.1454	12.845	4
57	0.8629	0.7900	0.8629	12.817	0.1480	12.819	3
58	0.8658	0.7878	0.8658	12.791	0.1506	12.793	2
59	0.8687	0.7856	0.8687	12.765	0.1532	12.767	1
60	0.8715	0.7834	0.8715	12.739	0.1558	12.741	0

85°

134

5°

M	Sen	Cos	Tan	Col	Sec	Csc	M
0	0.8715	0.9619	0.8715	0.8749	1.0038	11.074	60
1	0.8744	0.9621	0.8744	0.8778	0.0038	11.076	59
2	0.8773	0.9624	0.8773	0.8807	0.0039	11.078	58
3	0.8802	0.9627	0.8802	0.8837	0.0039	11.080	57
4	0.8831	0.9630	0.8831	0.8866	0.0039	11.082	56
5	0.8860	0.9633	0.8860	0.8895	0.0040	11.084	55
6	0.8889	0.9636	0.8889	0.8925	0.0040	11.086	54
7	0.8918	0.9639	0.8918	0.8954	0.0040	11.088	53
8	0.8947	0.9642	0.8947	0.8984	0.0040	11.090	52
9	0.8976	0.9645	0.8976	0.9013	0.0040	11.092	51
10	0.9005	0.9648	0.9005	0.9043	0.0040	11.094	50
11	0.9034	0.9651	0.9034	0.9072	0.0041	11.096	49
12	0.9063	0.9654	0.9063	0.9101	0.0041	11.098	48
13	0.9092	0.9657	0.9092	0.9130	0.0041	11.100	47
14	0.9121	0.9660	0.9121	0.9159	0.0041	11.102	46
15	0.9150	0.9663	0.9150	0.9188	0.0042	11.104	45
16	0.9179	0.9666	0.9179	0.9218	0.0042	11.106	44
17	0.9208	0.9669	0.9208	0.9247	0.0042	11.108	43
18	0.9237	0.9672	0.9237	0.9277	0.0043	11.110	42
19	0.9266	0.9675	0.9266	0.9306	0.0043	11.112	41
20	0.9295	0.9678	0.9295	0.9335	0.0043	11.114	40
21	0.9324	0.9681	0.9324	0.9365	0.0044	11.116	39
22	0.9353	0.9684	0.9353	0.9394	0.0044	11.118	38
23	0.9382	0.9687	0.9382	0.9423	0.0044	11.120	37
24	0.9411	0.9690	0.9411	0.9453	0.0044	11.122	36
25	0.9440	0.9693	0.9440	0.9482	0.0044	11.124	35
26	0.9469	0.9696	0.9469	0.9512	0.0044	11.126	34
27	0.9498	0.9699	0.9498	0.9541	0.0045	11.128	33
28	0.9527	0.9702	0.9527	0.9571	0.0045	11.130	32
29	0.9556	0.9705	0.9556	0.9600	0.0045	11.132	31
30	0.9585	0.9708	0.9585	0.9630	0.0045	11.134	30
31	0.9614	0.9711	0.9614	0.9659	0.0045	11.136	29
32	0.9643	0.9714	0.9643	0.9689	0.0046	11.138	28
33	0.9672	0.9717	0.9672	0.9718	0.0046	11.140	27
34	0.9701	0.9720	0.9701	0.9748	0.0046	11.142	26
35	0.9730	0.9723	0.9730	0.9777	0.0046	11.144	25
36	0.9759	0.9726	0.9759	0.9807	0.0046	11.146	24
37	0.9788	0.9729	0.9788	0.9836	0.0046	11.148	23
38	0.9817	0.9732	0.9817	0.9866	0.0046	11.150	22
39	0.9846	0.9735	0.9846	0.9895	0.0046	11.152	21
40	0.9875	0.9738	0.9875	0.9925	0.0046	11.154	20
41	0.9904	0.9741	0.9904	0.9954	0.0046	11.156	19
42	0.9933	0.9744	0.9933	0.9984	0.0046	11.158	18
43	0.9962	0.9747	0.9962	1.0013	0.0046	11.160	17
44	0.9991	0.9750	0.9991	1.0043	0.0046	11.162	16
45	1.0020	0.9753	1.0020	1.0072	0.0046	11.164	15
46	1.0049	0.9756	1.0049	1.0102	0.0046	11.166	14
47	1.0078	0.9759	1.0078	1.0131	0.0046	11.168	13
48	1.0107	0.9762	1.0107	1.0161	0.0046	11.170	12
49	1.0136	0.9765	1.0136	1.0190	0.0046	11.172	11
50	1.0165	0.9768	1.0165	1.0220	0.0046	11.174	10
51	1.0194	0.9771	1.0194	1.0249	0.0046	11.176	9
52	1.0223	0.9774	1.0223	1.0279	0.0046	11.178	8
53	1.0252	0.9777	1.0252	1.0308	0.0046	11.180	7
54	1.0281	0.9780	1.0281	1.0338	0.0046	11.182	6
55	1.0310	0.9783	1.0310	1.0367	0.0046	11.184	5
56	1.0339	0.9786	1.0339	1.0397	0.0046	11.186	4
57	1.0368	0.9789	1.0368	1.0426	0.0046	11.188	3
58	1.0397	0.9792	1.0397	1.0456	0.0046	11.190	2
59	1.0426	0.9795	1.0426	1.0485	0.0046	11.192	1
60	1.0455	0.9798	1.0455	1.0515	0.0046	11.194	0

84°

135

M	Sen	Cos.	Tan	Col	Sec.	Csc.	M
0	10453	99452	10510	9.5144	1.0055	9.5688	60
1	10482	99449	10540	4678	0055	5404	59
2	10511	99446	10569	4678	0056	5414	58
3	10540	99443	10599	4351	0056	4880	57
4	10568	99440	10628	4090	0056	4670	56
5	10597	99437	10657	3831	1.0057	9.4362	55
6	10626	99434	10687	3572	0057	4405	54
7	10655	99431	10716	3315	0057	3890	53
8	10684	99428	10746	3058	0058	3346	52
9	10713	99424	10775	2805	1.0058	9.1092	51
10	10742	99421	10805	2558	0058	2842	50
11	10771	99418	10834	2302	0059	2593	49
12	10800	99415	10863	2051	0059	2346	48
13	10829	99412	10893	1803	0059	2100	47
14	10858	99409	10922	1555	1.0059	9.1855	46
15	10887	99406	10952	1309	0060	8.479	45
16	10916	99402	10981	1054	0060	7.723	44
17	10945	99399	11011	800	0061	7.004	43
18	10974	99396	11040	545	0061	6.318	42
19	11003	99393	11069	0338	0061	5.659	41
20	11031	99390	11099	0099	0062	5.025	40
21	11060	99386	11128	8360	0062	4.414	39
22	11089	99383	11158	5623	0062	3.825	38
23	11118	99380	11187	9387	0062	3.264	37
24	11147	99377	11217	7152	0062	2.731	36
25	11176	99373	11246	4918	0063	2.225	35
26	11205	99370	11275	2686	0063	1.744	34
27	11234	99367	11304	495	0064	1.293	33
28	11263	99364	11333	8234	0064	0.865	32
29	11292	99360	11362	5586	0064	0.465	31
30	11320	99357	11392	87769	0065	0.083	30
31	11349	99354	11422	5942	0065	0.112	29
32	11378	99350	11452	2317	0065	0.665	28
33	11407	99347	11482	7093	0066	7.444	27
34	11436	99344	11511	4270	0066	6.655	26
35	11465	99341	11541	1454	0066	5.907	25
36	11494	99337	11570	6472	0067	5.198	24
37	11523	99334	11600	3498	0067	4.528	23
38	11551	99330	11630	5989	0067	3.895	22
39	11580	99327	11659	3722	0068	3.295	21
40	11609	99324	11688	83555	1.0068	8.6138	20
41	11638	99320	11718	5340	0068	8.068	19
42	11667	99317	11747	2326	0068	7.568	18
43	11696	99314	11777	4913	0069	7.109	17
44	11725	99310	11806	1896	0069	6.689	16
45	11754	99307	11836	4489	1.0070	6.307	15
46	11783	99303	11865	1479	0070	5.961	14
47	11811	99300	11895	4070	0070	5.648	13
48	11840	99296	11924	3862	0071	5.365	12
49	11869	99293	11954	3655	0071	5.101	11
50	11898	99290	11983	8345	1.0071	8.4046	10
51	11927	99286	12013	3244	0072	7.844	9
52	11956	99283	12042	3040	0072	7.404	8
53	11985	99279	12072	2837	0073	7.000	7
54	12014	99276	12101	2635	0073	6.630	6
55	12043	99272	12131	2434	1.0073	6.291	5
56	12071	99269	12161	2234	0074	5.981	4
57	12100	99265	12190	2035	0074	5.699	3
58	12129	99262	12219	1837	0074	5.444	2
59	12158	99258	12248	1640	0075	5.215	1
60	12187	99255	12278	8.1443	1.0075	8.2055	0

M	Sen	Cos.	Tan	Col	Sec.	Csc.	M
0	12187	99255	12278	8.1443	1.0075	8.2055	60
1	12216	99251	12308	1248	0075	1861	59
2	12245	99247	12337	1083	0076	1698	58
3	12274	99243	12367	918	0076	1546	57
4	12303	99239	12396	754	0077	1404	56
5	12332	99235	12426	590	0077	1272	55
6	12361	99231	12455	426	0078	1150	54
7	12390	99227	12485	262	0078	1038	53
8	12419	99223	12514	99	0079	936	52
9	12448	99219	12544	371	0079	844	51
10	12477	99215	12573	95	0080	761	50
11	12506	99211	12603	334	0080	687	49
12	12535	99207	12632	59	0081	621	48
13	12564	99203	12662	395	0081	562	47
14	12593	99200	12691	200	0082	510	46
15	12622	99196	12721	87	0082	464	45
16	12651	99192	12750	266	0083	424	44
17	12680	99188	12780	66	0083	389	43
18	12709	99184	12810	324	0084	358	42
19	12738	99180	12840	862	0084	330	41
20	12767	99176	12870	140	0085	304	40
21	12796	99172	12900	525	0085	280	39
22	12825	99168	12930	111	0086	257	38
23	12854	99164	12960	371	0086	236	37
24	12883	99160	12990	836	0087	217	36
25	12912	99156	13020	1306	0087	200	35
26	12941	99152	13050	1781	0088	184	34
27	12970	99148	13080	2251	0088	170	33
28	12999	99144	13110	2766	0089	157	32
29	13028	99140	13140	3327	0089	145	31
30	13057	99136	13170	3934	0090	134	30
31	13086	99132	13200	4588	0090	124	29
32	13115	99128	13230	5289	0091	115	28
33	13144	99124	13260	6038	0091	107	27
34	13173	99120	13290	6837	0092	100	26
35	13202	99116	13320	7677	0092	94	25
36	13231	99112	13350	8559	0093	89	24
37	13260	99108	13380	9484	0093	85	23
38	13289	99104	13410	10454	0094	81	22
39	13318	99100	13440	11670	0094	78	21
40	13347	99096	13470	13534	0095	75	20
41	13376	99092	13500	15058	0095	72	19
42	13405	99088	13530	17344	0096	70	18
43	13434	99084	13560	20404	0096	68	17
44	13463	99080	13590	24250	0097	66	16
45	13492	99076	13620	28904	0097	64	15
46	13521	99072	13650	34380	0098	62	14
47	13550	99068	13680	40704	0098	61	13
48	13579	99064	13710	47900	0099	60	12
49	13608	99060	13740	56000	0099	59	11
50	13637	99056	13770	65040	0100	58	10
51	13666	99052	13800	75060	0100	57	9
52	13695	99048	13830	86100	0101	56	8
53	13724	99044	13860	98200	0101	55	7
54	13753	99040	13890	111400	0102	54	6
55	13782	99036	13920	131800	0102	53	5
56	13811	99032	13950	154400	0103	52	4
57	13840	99028	13980	179300	0103	51	3
58	13869	99024	14010	206600	0104	50	2
59	13898	99020	14040	246500	0104	49	1
60	13927	99016	14070	299200	0105	48	0

M	Sen.	Cos.	Tan.	Col.	Sec.	Csc.	M
0	1.5643	9.6769	1.5638	6.3137	1.0125	6.3834	60
1	1.5672	9.6764	1.5668	6.3019	1.0125	6.3807	59
2	1.5701	9.6750	1.5698	6.2901	1.0125	6.3850	58
3	1.5730	9.6735	1.5728	6.2783	1.0125	6.3874	57
4	1.5758	9.6720	1.5755	6.2665	1.0125	6.3898	56
5	1.5787	9.6705	1.5782	6.2548	1.0125	6.3922	55
6	1.5815	9.6690	1.5809	6.2431	1.0125	6.3946	54
7	1.5844	9.6675	1.5836	6.2315	1.0125	6.3970	53
8	1.5872	9.6660	1.5863	6.2200	1.0125	6.3994	52
9	1.5900	9.6645	1.5890	6.2085	1.0125	6.4018	51
10	1.5929	9.6630	1.5917	6.1970	1.0125	6.4042	50
11	1.5957	9.6615	1.5944	6.1855	1.0125	6.4066	49
12	1.5985	9.6600	1.5971	6.1740	1.0125	6.4090	48
13	1.6014	9.6585	1.6000	6.1625	1.0125	6.4114	47
14	1.6042	9.6570	1.6027	6.1510	1.0125	6.4138	46
15	1.6070	9.6555	1.6054	6.1395	1.0125	6.4162	45
16	1.6098	9.6540	1.6081	6.1280	1.0125	6.4186	44
17	1.6126	9.6525	1.6108	6.1165	1.0125	6.4210	43
18	1.6154	9.6510	1.6135	6.1050	1.0125	6.4234	42
19	1.6182	9.6495	1.6162	6.0935	1.0125	6.4258	41
20	1.6210	9.6480	1.6189	6.0820	1.0125	6.4282	40
21	1.6238	9.6465	1.6216	6.0705	1.0125	6.4306	39
22	1.6266	9.6450	1.6243	6.0590	1.0125	6.4330	38
23	1.6294	9.6435	1.6270	6.0475	1.0125	6.4354	37
24	1.6322	9.6420	1.6297	6.0360	1.0125	6.4378	36
25	1.6350	9.6405	1.6324	6.0245	1.0125	6.4402	35
26	1.6378	9.6390	1.6351	6.0130	1.0125	6.4426	34
27	1.6406	9.6375	1.6378	6.0015	1.0125	6.4450	33
28	1.6434	9.6360	1.6405	5.9900	1.0125	6.4474	32
29	1.6462	9.6345	1.6432	5.9785	1.0125	6.4498	31
30	1.6490	9.6330	1.6459	5.9670	1.0125	6.4522	30
31	1.6518	9.6315	1.6486	5.9555	1.0125	6.4546	29
32	1.6546	9.6300	1.6513	5.9440	1.0125	6.4570	28
33	1.6574	9.6285	1.6540	5.9325	1.0125	6.4594	27
34	1.6602	9.6270	1.6567	5.9210	1.0125	6.4618	26
35	1.6630	9.6255	1.6594	5.9095	1.0125	6.4642	25
36	1.6658	9.6240	1.6621	5.8980	1.0125	6.4666	24
37	1.6686	9.6225	1.6648	5.8865	1.0125	6.4690	23
38	1.6714	9.6210	1.6675	5.8750	1.0125	6.4714	22
39	1.6742	9.6195	1.6702	5.8635	1.0125	6.4738	21
40	1.6770	9.6180	1.6729	5.8520	1.0125	6.4762	20
41	1.6798	9.6165	1.6756	5.8405	1.0125	6.4786	19
42	1.6826	9.6150	1.6783	5.8290	1.0125	6.4810	18
43	1.6854	9.6135	1.6810	5.8175	1.0125	6.4834	17
44	1.6882	9.6120	1.6837	5.8060	1.0125	6.4858	16
45	1.6910	9.6105	1.6864	5.7945	1.0125	6.4882	15
46	1.6938	9.6090	1.6891	5.7830	1.0125	6.4906	14
47	1.6966	9.6075	1.6918	5.7715	1.0125	6.4930	13
48	1.6994	9.6060	1.6945	5.7600	1.0125	6.4954	12
49	1.7022	9.6045	1.6972	5.7485	1.0125	6.4978	11
50	1.7050	9.6030	1.7000	5.7370	1.0125	6.5002	10
51	1.7078	9.6015	1.7027	5.7255	1.0125	6.5026	9
52	1.7106	9.6000	1.7054	5.7140	1.0125	6.5050	8
53	1.7134	9.5985	1.7081	5.7025	1.0125	6.5074	7
54	1.7162	9.5970	1.7108	5.6910	1.0125	6.5098	6
55	1.7190	9.5955	1.7135	5.6795	1.0125	6.5122	5
56	1.7218	9.5940	1.7162	5.6680	1.0125	6.5146	4
57	1.7246	9.5925	1.7189	5.6565	1.0125	6.5170	3
58	1.7274	9.5910	1.7216	5.6450	1.0125	6.5194	2
59	1.7302	9.5895	1.7243	5.6335	1.0125	6.5218	1
60	1.7330	9.5880	1.7270	5.6220	1.0125	6.5242	0

M	Sen.	Cos.	Tan.	Col.	Sec.	Csc.	M
0	1.3917	9.9027	1.4054	7.1154	1.0988	7.1853	60
1	1.3946	9.9013	1.4084	7.1004	1.0988	7.1704	59
2	1.3975	9.9000	1.4113	7.0854	1.0988	7.1555	58
3	1.4004	9.9015	1.4143	7.0706	1.0988	7.1406	57
4	1.4033	9.9010	1.4173	7.0558	1.0988	7.1257	56
5	1.4061	9.9006	1.4202	7.0410	1.0988	7.1108	55
6	1.4090	9.9002	1.4232	7.0264	1.0988	7.0959	54
7	1.4118	9.9000	1.4262	7.0118	1.0988	7.0810	53
8	1.4147	9.8998	1.4292	7.0000	1.0988	7.0661	52
9	1.4176	9.8996	1.4321	6.9877	1.0988	7.0512	51
10	1.4204	9.8995	1.4351	6.9754	1.0988	7.0363	50
11	1.4233	9.8994	1.4380	6.9632	1.0988	7.0214	49
12	1.4262	9.8993	1.4410	6.9510	1.0988	7.0065	48
13	1.4291	9.8992	1.4440	6.9388	1.0988	6.9916	47
14	1.4320	9.8991	1.4470	6.9266	1.0988	6.9767	46
15	1.4349	9.8990	1.4500	6.9144	1.0988	6.9618	45
16	1.4378	9.8989	1.4530	6.9022	1.0988	6.9469	44
17	1.4407	9.8988	1.4560	6.8900	1.0988	6.9320	43
18	1.4436	9.8987	1.4590	6.8778	1.0988	6.9171	42
19	1.4465	9.8986	1.4620	6.8656	1.0988	6.9022	41
20	1.4494	9.8985	1.4650	6.8534	1.0988	6.8873	40
21	1.4523	9.8984	1.4680	6.8412	1.0988	6.8724	39
22	1.4552	9.8983	1.4710	6.8290	1.0988	6.8575	38
23	1.4581	9.8982	1.4740	6.8168	1.0988	6.8426	37
24	1.4610	9.8981	1.4770	6.8046	1.0988	6.8277	36
25	1.4639	9.8980	1.4800	6.7924	1.0988	6.8128	35
26	1.4668	9.8979	1.4830	6.7802	1.0988	6.7979	34
27	1.4697	9.8978	1.4860	6.7680	1.0988	6.7830	33
28	1.4726	9.8977	1.4890	6.7558	1.0988	6.7681	32
29	1.4755	9.8976	1.4920	6.7436	1.0988	6.7532	31
30	1.4784	9.8975	1.4950	6.7314	1.0988	6.7383	30
31	1.4813	9.8974	1.4980	6.7192	1.0988	6.7234	29
32	1.4842	9.8973	1.5010	6.7070	1.0988	6.7085	28
33	1.4871	9.8972	1.5040	6.6948	1.0988	6.6936	27
34	1.4900	9.8971	1.5070	6.6826	1.0988	6.6787	26
35	1.4929	9.8970	1.5100	6.6704	1.0988	6.6638	25
36	1.4958	9.8969	1.5130	6.6582	1.0988	6.6489	24
37	1.4987	9.8968	1.5160	6.6460	1.0988	6.6340	23
38	1.5016	9.8967	1.5190	6.6338	1.0988	6.6191	22
39	1.5045	9.8966	1.5220	6.6216	1.0988	6.6042	21
40	1.5074	9.8965	1.5250	6.6094	1.0988	6.5893	20
41	1.5103	9.8964	1.5280	6.5972	1.0988	6.5744	19
42	1.5132	9.8963	1.5310	6.5850	1.0988	6.5595	18
43	1.5161	9.8962	1.5340	6.5728	1.0988	6.5446	17
44	1.5190	9.8961	1.5370	6.5606	1.0988	6.5297	16
45	1.5219	9.8960	1.5400	6.5484	1.0988	6.5148	15
46	1.5248	9.8959	1.5430	6.5362	1.0988	6.4999	14
47	1.5277	9.8958	1.5460	6.5240	1.0988	6.4850	13
48	1.5306	9.8957	1.5490	6.5118	1.0988	6.4701	12
49	1.5335	9.8956	1.5520	6.5000	1.0988	6.4552	11
50	1.5364	9.8955	1.5550	6.4882	1.0988	6.4403	10
51	1.5393	9.8954	1.5580	6.4764	1.0988	6.4254	9
52	1.5422	9.8953	1.5610	6.4646	1.0988	6.4105	8
53	1.5451	9.8952	1.5640	6.4528	1.0988	6.3956	7
54	1.5480	9.8951	1.5670	6.4410	1.0988	6.3807	6
55	1.5509	9.8950	1.5700	6.4292	1.0988	6.3658	5
56	1.5538	9.8949	1.5730	6.4174	1.0988	6.3509	4
57	1.5567	9.8948	1.5760	6.4056	1.0988	6.3360	3
58	1.5596	9.8947	1.5790	6.3938	1.0988	6.3211	2
59	1.5625	9.8946	1.5820	6.3820	1.0988	6.3062	1
60	1.5654	9.8945	1.5850	6.3702	1.0988	6.2913	0

M	Sen.	Cos.	Tan.	Col.	Sec.	Csc.	M
0	17365	98481	17633	5.6713	1.0154	5.7588	60
1	17392	98476	17663	6.6616	0.1555	7.4932	59
2	17422	98471	17693	6.5720	0.1555	7.398	58
3	17451	98465	17723	6.4725	0.156	7.304	57
4	17479	98459	17753	6.3739	0.156	7.210	56
5	17508	98453	17783	6.2753	0.157	7.117	55
6	17536	98446	17813	6.1766	0.158	7.024	54
7	17565	98440	17843	6.0780	0.158	6.931	53
8	17594	98434	17873	5.9795	0.159	6.838	52
9	17622	98428	17903	5.8810	0.159	6.745	51
10	17651	98423	17933	5.7825	0.159	6.653	50
11	17680	98417	17963	5.6840	0.159	6.561	49
12	17708	98411	17993	5.5855	0.160	6.470	48
13	17737	98405	18023	5.4870	0.161	6.379	47
14	17766	98400	18053	5.3885	0.162	6.288	46
15	17795	98394	18083	5.2900	0.162	6.197	45
16	17824	98388	18113	5.1915	0.163	6.106	44
17	17852	98382	18143	5.0930	0.163	6.015	43
18	17881	98376	18173	5.0226	0.164	5.924	42
19	17909	98370	18203	4.9336	0.164	5.833	41
20	17937	98364	18233	4.8446	0.165	5.742	40
21	17966	98358	18263	4.7556	0.165	5.651	39
22	17995	98352	18293	4.6666	0.166	5.560	38
23	18023	98346	18323	4.5776	0.166	5.469	37
24	18052	98340	18353	4.4886	0.167	5.378	36
25	18080	98334	18383	4.3996	0.167	5.287	35
26	18109	98328	18413	4.3106	0.168	5.196	34
27	18137	98322	18443	4.2216	0.168	5.105	33
28	18166	98316	18473	4.1326	0.169	5.014	32
29	18195	98310	18503	4.0436	0.170	4.923	31
30	18223	98304	18533	3.9546	0.170	4.832	30
31	18252	98298	18563	3.8656	0.171	4.741	29
32	18281	98292	18593	3.7766	0.172	4.650	28
33	18309	98286	18623	3.6876	0.172	4.559	27
34	18338	98280	18653	3.5986	0.172	4.468	26
35	18366	98274	18683	3.5096	0.173	4.377	25
36	18395	98268	18713	3.4206	0.174	4.286	24
37	18424	98262	18743	3.3316	0.174	4.195	23
38	18452	98256	18773	3.2426	0.175	4.104	22
39	18481	98250	18803	3.1536	0.175	4.013	21
40	18509	98244	18833	3.0646	0.176	3.922	20
41	18538	98238	18863	2.9756	0.176	3.831	19
42	18567	98232	18893	2.8866	0.177	3.740	18
43	18595	98226	18923	2.7976	0.177	3.649	17
44	18624	98220	18953	2.7086	0.178	3.558	16
45	18652	98214	18983	2.6196	0.178	3.467	15
46	18681	98208	19013	2.5306	0.179	3.376	14
47	18709	98202	19043	2.4416	0.179	3.285	13
48	18738	98196	19073	2.3526	0.180	3.194	12
49	18766	98190	19103	2.2636	0.180	3.103	11
50	18795	98184	19133	2.1746	0.181	3.012	10
51	18824	98178	19163	2.0856	0.181	2.921	9
52	18852	98172	19193	2.0226	0.182	2.830	8
53	18881	98166	19223	2.0111	0.183	2.739	7
54	18910	98160	19253	2.0129	0.184	2.648	6
55	18938	98154	19283	2.0147	0.184	2.557	5
56	18967	98148	19313	2.0165	0.185	2.466	4
57	18995	98142	19343	2.0183	0.185	2.375	3
58	19024	98136	19373	2.0201	0.186	2.284	2
59	19052	98130	19403	2.0219	0.186	2.193	1
60	19081	98124	19433	2.0237	0.187	2.102	0

M	Sen.	Cos.	Tan.	Col.	Sec.	Csc.	M
0	19081	98118	19463	2.0255	0.187	2.011	60
1	19109	98112	19493	2.0273	0.188	1.920	59
2	19138	98106	19523	2.0291	0.188	1.829	58
3	19166	98100	19553	2.0309	0.189	1.738	57
4	19195	98094	19583	2.0327	0.189	1.647	56
5	19224	98088	19613	2.0345	0.190	1.556	55
6	19252	98082	19643	2.0363	0.190	1.465	54
7	19281	98076	19673	2.0381	0.191	1.374	53
8	19309	98070	19703	2.0399	0.191	1.283	52
9	19338	98064	19733	2.0417	0.192	1.192	51
10	19366	98058	19763	2.0435	0.192	1.101	50
11	19395	98052	19793	2.0453	0.193	1.010	49
12	19423	98046	19823	2.0471	0.193	0.919	48
13	19452	98040	19853	2.0489	0.194	0.828	47
14	19480	98034	19883	2.0507	0.194	0.737	46
15	19509	98028	19913	2.0525	0.195	0.646	45
16	19537	98022	19943	2.0543	0.195	0.555	44
17	19566	98016	19973	2.0561	0.196	0.464	43
18	19594	98010	20003	2.0579	0.196	0.373	42
19	19623	98004	20033	2.0597	0.197	0.282	41
20	19651	98000	20063	2.0615	0.197	0.191	40
21	19680	98000	20093	2.0633	0.198	0.100	39
22	19708	98000	20123	2.0651	0.198	0.009	38
23	19737	98000	20153	2.0669	0.199	0.000	37
24	19766	98000	20183	2.0687	0.199	0.000	36
25	19794	98000	20213	2.0705	0.200	0.000	35
26	19823	98000	20243	2.0723	0.200	0.000	34
27	19851	98000	20273	2.0741	0.201	0.000	33
28	19880	98000	20303	2.0759	0.201	0.000	32
29	19908	98000	20333	2.0777	0.202	0.000	31
30	19937	98000	20363	2.0795	0.202	0.000	30
31	19965	98000	20393	2.0813	0.203	0.000	29
32	19994	98000	20423	2.0831	0.203	0.000	28
33	20022	98000	20453	2.0849	0.204	0.000	27
34	20051	98000	20483	2.0867	0.204	0.000	26
35	20079	98000	20513	2.0885	0.205	0.000	25
36	20108	98000	20543	2.0903	0.205	0.000	24
37	20136	98000	20573	2.0921	0.206	0.000	23
38	20165	98000	20603	2.0939	0.206	0.000	22
39	20193	98000	20633	2.0957	0.207	0.000	21
40	20222	98000	20663	2.0975	0.207	0.000	20
41	20250	98000	20693	2.0993	0.208	0.000	19
42	20279	98000	20723	2.1011	0.208	0.000	18
43	20307	98000	20753	2.1029	0.209	0.000	17
44	20336	98000	20783	2.1047	0.209	0.000	16
45	20364	98000	20813	2.1065	0.210	0.000	15
46	20393	98000	20843	2.1083	0.210	0.000	14
47	20421	98000	20873	2.1101	0.211	0.000	13
48	20450	98000	20903	2.1119	0.211	0.000	12
49	20478	98000	20933	2.1137	0.212	0.000	11
50	20507	98000	20963	2.1155	0.212	0.000	10
51	20535	98000	20993	2.1173	0.213	0.000	9
52	20564	98000	21023	2.1191	0.213	0.000	8
53	20592	98000	21053	2.1209	0.214	0.000	7
54	20621	98000	21083	2.1227	0.214	0.000	6
55	20649	98000	21113	2.1245	0.215	0.000	5
56	20677	98000	21143	2.1263	0.215	0.000	4
57	20706	98000	21173	2.1281	0.216	0.000	3
58	20734	98000	21203	2.1299	0.216	0.000	2
59	20763	98000	21233	2.1317	0.217	0.000	1
60	20791	98000	21263	2.1335	0.217	0.000	0

M	Sen.	Cos.	Tan.	Cot.	Sec.	Csc.	M
0	.20791	.97815	.21256	4.7046	1.0223	4.8097	60
1	.20820	.97809	.21286	4.6979	.0224	8032	59
2	.20848	.97803	.21316	4.6912	.0225	7966	58
3	.20876	.97797	.21347	4.6845	.0225	7901	57
4	.20905	.97790	.21377	4.6778	.0226	7835	56
5	.20933	.97784	.21408	4.6712	1.0226	4.7770	55
6	.20962	.97778	.21438	4.6646	.0227	7706	54
7	.20990	.97772	.21468	4.6580	.0228	7641	53
8	.21019	.97766	.21499	4.6514	.0228	7576	52
9	.21047	.97760	.21529	4.6448	.0229	7512	51
10	.21076	.97754	.21560	4.6382	1.0230	4.7448	50
11	.21104	.97748	.21590	4.6317	.0230	7384	49
12	.21132	.97741	.21621	4.6252	.0231	7320	48
13	.21161	.97735	.21651	4.6187	.0232	7257	47
14	.21189	.97729	.21682	4.6122	.0232	7193	46
15	.21218	.97723	.21712	4.6057	1.0233	4.7130	45
16	.21246	.97717	.21742	4.5993	.0234	7067	44
17	.21275	.97711	.21773	4.5928	.0234	7004	43
18	.21303	.97704	.21803	4.5864	.0235	6942	42
19	.21331	.97698	.21834	4.5800	.0235	6879	41
20	.21360	.97692	.21864	4.5736	1.0236	4.6817	40
21	.21388	.97686	.21895	4.5673	.0237	6754	39
22	.21417	.97680	.21925	4.5609	.0237	6692	38
23	.21445	.97673	.21956	4.5546	.0238	6631	37
24	.21473	.97667	.21986	4.5483	.0239	6569	36
25	.21502	.97661	.22017	4.5420	1.0239	4.6507	35
26	.21530	.97655	.22047	4.5357	.0240	6446	34
27	.21559	.97648	.22078	4.5294	.0241	6385	33
28	.21587	.97642	.22108	4.5232	.0241	6324	32
29	.21615	.97636	.22139	4.5169	.0242	6263	31
30	.21644	.97630	.22169	4.5107	1.0243	4.6201	30
31	.21672	.97623	.22200	4.5045	.0243	6142	29
32	.21701	.97617	.22230	4.4983	.0244	6081	28
33	.21729	.97611	.22261	4.4921	.0245	6021	27
34	.21757	.97604	.22291	4.4860	.0245	5961	26
35	.21786	.97598	.22322	4.4799	1.0246	4.5901	25
36	.21814	.97592	.22353	4.4737	.0247	5841	24
37	.21843	.97585	.22383	4.4676	.0247	5782	23
38	.21871	.97579	.22414	4.4615	.0248	5722	22
39	.21899	.97573	.22444	4.4555	.0249	5663	21
40	.21928	.97566	.22475	4.4494	1.0249	4.5604	20
41	.21956	.97560	.22505	4.4434	.0250	5545	19
42	.21985	.97553	.22536	4.4373	.0251	5486	18
43	.22013	.97547	.22566	4.4313	.0251	5428	17
44	.22041	.97541	.22597	4.4253	.0252	5369	16
45	.22070	.97534	.22628	4.4194	1.0253	4.5311	15
46	.22098	.97528	.22658	4.4134	.0253	5253	14
47	.22126	.97521	.22689	4.4074	.0254	5195	13
48	.22155	.97515	.22719	4.4015	.0255	5137	12
49	.22183	.97508	.22750	4.3956	.0255	5079	11
50	.22211	.97502	.22781	4.3897	1.0256	4.5021	10
51	.22240	.97495	.22811	4.3838	.0257	4964	9
52	.22268	.97489	.22842	4.3779	.0257	4907	8
53	.22297	.97483	.22872	4.3721	.0258	4850	7
54	.22325	.97476	.22903	4.3662	.0259	4793	6
55	.22353	.97470	.22934	4.3604	1.0260	4.4736	5
56	.22382	.97463	.22964	4.3546	.0260	4679	4
57	.22410	.97457	.22995	4.3488	.0261	4623	3
58	.22438	.97450	.23025	4.3430	.0262	4566	2
59	.22467	.97443	.23056	4.3372	.0262	4510	1
60	.22495	.97437	.23087	4.3315	1.0263	4.4454	0

M	Sen.	Cos.	Tan.	Cot.	Sec.	Csc.	M
0	.22495	.97437	.23087	4.3315	1.0263	4.4454	60
1	.22523	.97430	.23117	.3257	.0264	4.398	59
2	.22552	.97424	.23148	.3200	.0264	4.342	58
3	.22580	.97417	.23179	.3143	.0265	4.287	57
4	.22608	.97411	.23209	.3086	.0266	4.231	56
5	.22637	.97404	.23240	4.3029	1.0266	4.176	55
6	.22665	.97398	.23270	.2972	.0267	4.121	54
7	.22693	.97391	.23301	.2916	.0268	4.065	53
8	.22722	.97384	.23332	.2859	.0268	4.011	52
9	.22750	.97378	.23363	.2803	.0269	3.956	51
10	.22778	.97371	.23393	4.2747	1.0270	4.3901	50
11	.22807	.97364	.23424	.2691	.0271	3.847	49
12	.22835	.97358	.23455	.2635	.0271	3.792	48
13	.22863	.97351	.23485	.2579	.0272	3.738	47
14	.22892	.97344	.23516	.2524	.0273	3.684	46
15	.22920	.97338	.23547	4.2468	1.0273	4.3630	45
16	.22948	.97331	.23577	.2413	.0274	3.576	44
17	.22977	.97324	.23608	.2358	.0275	3.522	43
18	.23005	.97318	.23639	.2303	.0276	3.469	42
19	.23033	.97311	.23670	.2248	.0276	3.415	41
20	.23061	.97304	.23700	4.2193	1.0277	4.3362	40
21	.23090	.97298	.23731	.2139	.0278	3.309	39
22	.23118	.97291	.23762	.2084	.0278	3.256	38
23	.23146	.97284	.23793	.2030	.0279	3.203	37
24	.23175	.97277	.23823	.1976	.0280	3.150	36
25	.23203	.97271	.23854	4.1921	1.0280	4.3098	35
26	.23231	.97264	.23885	.1867	.0281	3.045	34
27	.23260	.97257	.23916	.1814	.0282	2.993	33
28	.23288	.97250	.23946	.1760	.0283	2.941	32
29	.23316	.97244	.23977	.1706	.0283	2.888	31
30	.23344	.97237	.24008	4.1653	1.0284	4.2836	30
31	.23373	.97230	.24039	.1600	.0285	2.785	29
32	.23401	.97223	.24069	.1546	.0285	2.733	28
33	.23429	.97216	.24100	.1493	.0286	2.681	27
34	.23458	.97210	.24131	.1440	.0287	2.630	26
35	.23486	.97203	.24162	4.1388	1.0288	4.2579	25
36	.23514	.97196	.24192	.1335	.0288	2.527	24
37	.23542	.97189	.24223	.1282	.0289	2.476	23
38	.23571	.97182	.24254	.1230	.0290	2.425	22
39	.23599	.97175	.24285	.1178	.0291	2.375	21
40	.23627	.97169	.24316	4.1126	1.0291	4.2324	20
41	.23655	.97162	.24346	.1073	.0292	2.273	19
42	.23684	.97155	.24377	.1022	.0293	2.223	18
43	.23712	.97148	.24408	.0970	.0293	2.173	17
44	.23740	.97141	.24439	.0918	.0294	2.122	16
45	.23768	.97134	.24470	4.0867	1.0295	4.2072	15
46	.23797	.97127	.24501	.0815	.0296	2.022	14
47	.23825	.97120	.24531	.0764	.0296	1.972	13
48	.23853	.97113	.24562	.0713	.0297	1.923	12
49	.23881	.97106	.24593	.0662	.0298	1.873	11
50	.23910	.97099	.24624	4.0611	1.0299	4.1824	10
51	.23938	.97092	.24655	.0560	.0299	1.774	9
52	.23966	.97086	.24686	.0509	.0300	1.725	8
53	.23994	.97079	.24717	.0458	.0301	1.676	7
54	.24023	.97072	.24747	.0408	.0302	1.627	6
55	.24051	.97065	.24778	4.0358	1.0302	4.1578	5
56	.24079	.97058	.24809	.0307	.0303	1.529	4
57	.24107	.97051	.24840	.0257	.0304	1.481	3
58	.24136	.97044	.24871	.0207	.0305	1.432	2
59	.24164	.97037	.24902	.0157	.0305	1.384	1
60	.24192	.97029	.24933	4.0108	1.0306	4.1336	0

■	Sen.	Cos.	Tan.	Cot.	Sec.	Csc.	■
0	24192	97079	24933	4.0108	1.0306	4.1336	60
1	24220	97022	24964	0058	0307	1.1287	59
2	24249	97015	24995	0009	0308	1.1239	58
3	24277	97008	25025	3.9959	0308	1.1191	57
4	24305	97001	25056	9910	0309	1.1144	56
5	24333	96994	25087	3.9851	1.0310	4.1096	55
6	24361	96987	25118	9812	0311	1.1048	54
7	24390	96980	25149	9763	0311	1.1001	53
8	24418	96973	25180	9714	0312	0953	52
9	24446	96966	25211	9665	0313	0906	51
10	24474	96959	25242	3.9616	1.0314	4.0859	50
11	24502	96952	25273	9568	0314	0812	49
12	24531	96944	25304	9520	0315	0765	48
13	24559	96937	25335	9471	0316	0718	47
14	24587	96930	25366	9423	0317	0672	46
15	24615	96923	25397	3.9375	1.0317	4.0625	45
16	24643	96916	25428	9327	0318	0579	44
17	24672	96909	25459	9279	0319	0532	43
18	24700	96901	25490	9231	0320	0486	42
19	24728	96894	25521	9184	0320	0440	41
20	24756	96887	25552	3.9136	1.0321	4.0394	40
21	24784	96880	25583	9089	0322	0348	39
22	24813	96873	25614	9042	0323	0302	38
23	24841	96865	25645	8994	0323	0256	37
24	24869	96858	25676	8947	0324	0211	36
25	24897	96851	25707	3.8900	1.0325	4.0165	35
26	24925	96844	25738	8853	0326	0120	34
27	24953	96836	25769	8807	0327	0074	33
28	24982	96829	25800	8760	0327	0029	32
29	25010	96822	25831	8713	0328	1.9984	31
30	25038	96815	25862	3.8667	1.0329	3.9939	30
31	25066	96807	25893	8621	0330	9894	29
32	25094	96800	25924	8574	0330	9850	28
33	25122	96793	25955	8528	0331	9805	27
34	25151	96785	25986	8482	0332	9760	26
35	25179	96778	26017	3.8436	1.0333	3.9716	25
36	25207	96771	26048	8390	0334	9672	24
37	25235	96763	26079	8345	0334	9627	23
38	25263	96756	26110	8299	0335	9583	22
39	25291	96749	26141	8254	0336	9539	21
40	25319	96741	26172	3.8208	1.0337	3.9495	20
41	25348	96734	26203	8163	0338	9451	19
42	25376	96727	26234	8118	0338	9408	18
43	25404	96719	26266	8073	0339	9364	17
44	25432	96712	26297	8027	0340	9320	16
45	25460	96704	26328	3.7983	1.0341	3.9277	15
46	25488	96697	26359	7938	0341	9234	14
47	25516	96690	26390	7893	0342	9190	13
48	25544	96682	26421	7848	0343	9147	12
49	25573	96675	26452	7804	0344	9104	11
50	25601	96667	26483	3.7759	1.0345	3.9061	10
51	25629	96660	26514	7715	0345	9018	9
52	25657	96652	26545	7671	0346	8976	8
53	25685	96645	26577	7627	0347	8933	7
54	25713	96638	26608	7583	0348	8890	6
55	25741	96630	26639	3.7539	1.0349	3.8848	5
56	25769	96623	26670	7495	0349	8805	4
57	25798	96615	26701	7451	0350	8763	3
58	25826	96608	26732	7407	0351	8721	2
59	25854	96600	26764	7364	0352	8679	1
60	25882	96592	26795	3.7320	1.0353	3.8637	0

■	Cos.	Sen.	Cot.	Tan.	Csc.	Sec.	■
---	------	------	------	------	------	------	---

15°

M	Sen.	Cos.	Tan.	Cot.	Sec.	Csc.	M
0	25882	96592	26795	3.7320	1.0353	3.8637	60
1	25910	96585	26826	7277	0353	8595	59
2	25938	96577	26857	7234	0354	8553	58
3	25966	96570	26888	7191	0355	8512	57
4	25994	96562	26920	7147	0356	8470	56
5	26022	96555	26951	3.7104	1.0357	3.8428	55
6	26050	96547	26982	7062	0358	8387	54
7	26078	96540	27013	7019	0358	8346	53
8	26107	96532	27044	6976	0359	8304	52
9	26135	96524	27076	6933	0360	8263	51
10	26163	96517	27107	3.6891	1.0361	3.8222	50
11	26191	96509	27138	6848	0362	8181	49
12	26219	96502	27169	6806	0362	8140	48
13	26247	96494	27201	6764	0363	8100	47
14	26275	96486	27232	6722	0364	8059	46
15	26303	96479	27263	3.6679	1.0365	3.8018	45
16	26331	96471	27294	6637	0366	7978	44
17	26359	96463	27326	6596	0367	7937	43
18	26387	96456	27357	6554	0367	7897	42
19	26415	96448	27388	6512	0368	7857	41
20	26443	96440	27419	3.6470	1.0369	3.7816	40
21	26471	96433	27451	6429	0370	7776	39
22	26499	96425	27482	6387	0371	7736	38
23	26527	96417	27513	6346	0371	7697	37
24	26556	96409	27544	6305	0372	7657	36
25	26584	96402	27576	3.6263	1.0373	3.7617	35
26	26612	96394	27607	6222	0374	7577	34
27	26640	96386	27638	6181	0375	7538	33
28	26668	96378	27670	6140	0376	7498	32
29	26696	96371	27701	6100	0376	7459	31
30	26724	96363	27732	3.6059	1.0377	3.7420	30
31	26752	96355	27764	6018	0378	7380	29
32	26780	96347	27795	5977	0379	7341	28
33	26808	96340	27826	5937	0380	7302	27
34	26836	96332	27858	5896	0381	7263	26
35	26864	96324	27889	3.5856	1.0382	3.7224	25
36	26892	96316	27920	5816	0382	7186	24
37	26920	96308	27952	5776	0383	7147	23
38	26948	96301	27983	5736	0384	7108	22
39	26976	96293	28014	5696	0385	7070	21
40	27004	96285	28046	3.5656	1.0386	3.7031	20
41	27032	96277	28077	5616	0387	6993	19
42	27060	96269	28109	5576	0387	6955	18
43	27088	96261	28140	5536	0388	6917	17
44	27116	96253	28171	5497	0389	6878	16
45	27144	96245	28203	3.5457	1.0390	3.6840	15
46	27172	96238	28234	5418	0391	6802	14
47	27200	96230	28266	5378	0392	6765	13
48	27228	96222	28297	5339	0393	6727	12
49	27256	96214	28328	5300	0393	6689	11
50	27284	96206	28360	3.5261	1.0394	3.6651	10
51	27312	96198	28391	5222	0395	6614	9
52	27340	96190	28423	5183	0396	6576	8
53	27368	96182	28454	5144	1.0397	6539	7
54	27396	96174	28486	5105	0398	6502	6
55	27424	96166	28517	3.5066	1.0399	3.5464	5
56	27452	96158	28549	5028	0399	6427	4
57	27480	96150	28580	4989	0400	6390	3
58	27508	96142	28611	4951	0401	6353	2
59	27536	96134	28643	4912	0402	6316	1
60	27564	96126	28674	3.4874	1.0403	3.6279	0

74°

145

M	Sen.	Cos.	Tan.	Cot.	Sec.	Csc.	M
0	27564	.96126	.28674	3.4874	1.0403	3.6279	60
1	27592	.96118	.28706	4.836	.0404	6243	59
2	27620	.96110	.28737	4.798	.0405	6206	58
3	27648	.96102	.28769	4.760	.0406	6169	57
4	27675	.96094	.28800	4.722	.0406	6133	56
5	27703	.96086	.28832	3.4684	1.0407	3.6096	55
6	27731	.96078	.28863	.4646	.0408	6060	54
7	27759	.96070	.28895	.4608	.0409	6024	53
8	27787	.96062	.28926	4.570	.0410	5987	52
9	27815	.96054	.28958	.4533	.0411	5951	51
10	27843	.96045	.28990	3.4495	1.0412	3.5915	50
11	27871	.96037	.29021	4.458	.0413	5879	49
12	27899	.96029	.29053	4.420	.0413	5843	48
13	27927	.96021	.29084	4.383	.0414	5807	47
14	27955	.96013	.29116	4.345	.0415	5772	46
15	27983	.96005	.29147	3.4308	1.0416	3.5736	45
16	28011	.95997	.29179	4.771	.0417	5700	44
17	28039	.95989	.29210	4.734	.0418	5665	43
18	28067	.95980	.29242	4.197	.0419	5629	42
19	28094	.95972	.29274	4.160	.0420	5594	41
20	28122	.95964	.29305	3.4124	1.0420	3.5559	40
21	28150	.95956	.29337	4.087	.0421	5523	39
22	28178	.95948	.29368	4.050	.0422	5488	38
23	28206	.95940	.29400	4.014	.0423	5453	37
24	28234	.95931	.29432	.3977	.0424	5418	36
25	28262	.95923	.29463	3.3941	1.0425	3.5383	35
26	28290	.95915	.29495	.3904	.0426	5348	34
27	28318	.95907	.29526	3.868	.0427	5313	33
28	28346	.95898	.29558	3.832	.0428	5279	32
29	28374	.95890	.29590	3.795	.0428	5244	31
30	28401	.95882	.29621	3.759	1.0429	3.5209	30
31	28429	.95874	.29653	.3723	.0430	5175	29
32	28457	.95865	.29685	.3687	.0431	5140	28
33	28485	.95857	.29716	.3651	.0432	5106	27
34	28513	.95849	.29748	.3616	.0433	5072	26
35	28541	.95840	.29780	3.3580	1.0434	3.5037	25
36	28569	.95832	.29811	3.544	.0435	5003	24
37	28597	.95824	.29843	.3509	.0436	4969	23
38	28624	.95816	.29875	.3473	.0437	4935	22
39	28652	.95807	.29906	3.438	.0438	4901	21
40	28680	.95799	.29938	3.3402	1.0438	3.4867	20
41	28708	.95791	.29970	.3367	.0439	4833	19
42	28736	.95782	3.0001	.3332	.0440	4799	18
43	28764	.95774	3.0033	.3296	.0441	4766	17
44	28792	.95765	3.0065	.3261	.0442	4732	16
45	28820	.95757	3.0096	3.3226	1.0443	3.4698	15
46	28847	.95749	3.0128	3.191	.0444	4665	14
47	28875	.95740	3.0160	3.156	.0445	4632	13
48	28903	.95732	3.0192	3.121	.0446	4598	12
49	28931	.95723	3.0223	3.087	.0447	4565	11
50	28959	.95715	3.0255	3.3052	1.0448	3.4532	10
51	28987	.95707	3.0287	3.017	.0448	4498	9
52	29014	.95698	3.0319	3.2983	.0449	4465	8
53	29042	.95690	3.0350	2.948	.0450	4432	7
54	29070	.95681	3.0382	2.914	.0451	4399	6
55	29098	.95673	3.0414	3.2879	1.0452	3.4366	5
56	29126	.95664	3.0446	2.845	.0453	4334	4
57	29154	.95656	3.0478	2.811	.0454	4301	3
58	29181	.95647	3.0509	2.777	.0455	4268	2
59	29209	.95639	3.0541	2.742	.0456	4236	1
60	29237	.95630	3.0573	3.2788	1.0457	3.4203	0
M	Cos.	Sen.	Cot.	Tan.	Csc.	Sec.	M

M	Sen.	Cos.	Tan.	Cot.	Sec.	Csc.	M
0	.29237	.95630	.30573	3.2708	1.0457	3.4203	60
1	.29265	.95622	.30605	2674	.0458	.4170	59
2	.29293	.95613	.30637	2640	.0459	.4138	58
3	.29321	.95605	.30668	2607	.0460	.4106	57
4	.29348	.95596	.30700	2573	.0461	.4073	56
5	.29376	.95588	.30732	3.2539	1.0461	3.4041	55
6	.29404	.95579	.30764	2505	.0462	.4009	54
7	.29432	.95571	.30796	2472	.0463	.3977	53
8	.29460	.95562	.30828	2438	.0464	.3945	52
9	.29487	.95554	.30859	2405	.0465	.3913	51
10	.29515	.95545	.30891	3.2371	1.0466	3.3881	50
11	.29543	.95536	.30923	.2334	.0467	.3849	49
12	.29571	.95528	.30955	2305	.0468	.3817	48
13	.29598	.95519	.30987	2271	.0469	.3785	47
14	.29626	.95511	.31019	2238	.0470	.3754	46
15	.29654	.95502	.31051	3.2205	1.0471	3.3722	45
16	.29682	.95493	.31083	2172	.0472	.3690	44
17	.29710	.95485	.31115	2139	.0473	.3659	43
18	.29737	.95476	.31146	2106	.0474	.3627	42
19	.29765	.95467	.31178	2073	.0475	.3596	41
20	.29793	.95459	.31210	3.2041	1.0476	3.3565	40
21	.29821	.95450	.31242	2008	.0477	.3534	39
22	.29848	.95441	.31274	1975	.0478	.3502	38
23	.29876	.95433	.31306	1942	.0478	.3471	37
24	.29904	.95424	.31338	1910	.0479	.3440	36
25	.29932	.95415	.31370	3.1877	1.0480	3.3409	35
26	.29959	.95407	.31402	1845	.0481	.3378	34
27	.29987	.95398	.31434	1813	.0482	.3347	33
28	.30015	.95389	.31466	1780	.0483	.3316	32
29	.30043	.95380	.31498	1748	.0484	.3286	31
30	.30070	.95372	.31530	3.1716	1.0485	3.3255	30
31	.30098	.95363	.31562	1684	.0486	.3224	29
32	.30126	.95354	.31594	1652	.0487	.3194	28
33	.30154	.95345	.31626	1620	.0488	.3163	27
34	.30181	.95337	.31658	1588	.0489	.3133	26
35	.30209	.95328	.31690	3.1556	1.0490	3.3102	25
36	.30237	.95319	.31722	1524	.0491	.3072	24
37	.30265	.95310	.31754	1492	.0492	.3042	23
38	.30292	.95301	.31786	1460	.0493	.3011	22
39	.30320	.95293	.31818	1429	.0494	.2981	21
40	.30348	.95284	.31850	3.1397	1.0495	3.2951	20
41	.30375	.95275	.31882	1366	.0496	.2921	19
42	.30403	.95266	.31914	1334	.0497	.2891	18
43	.30431	.95257	.31946	1303	.0498	.2861	17
44	.30459	.95248	.31978	1271	.0499	.2831	16
45	.30486	.95239	.32010	3.1240	1.0500	3.2801	15
46	.30514	.95231	.32042	1209	.0501	.2772	14
47	.30542	.95222	.32074	1177	.0502	.2742	13
48	.30569	.95213	.32106	1145	.0503	.2712	12
49	.30597	.95204	.32138	1115	.0504	.2683	11
50	.30625	.95195	.32171	3.1084	1.0505	3.2653	10
51	.30653	.95186	.32203	1053	.0506	.2624	9
52	.30680	.95177	.32235	1022	.0507	.2594	8
53	.30708	.95168	.32267	991	.0508	.2565	7
54	.30736	.95159	.32299	960	.0509	.2535	6
55	.30763	.95150	.32331	3.0930	1.0510	3.2506	5
56	.30791	.95141	.32363	889	.0511	.2477	4
57	.30819	.95132	.32395	868	.0512	.2448	3
58	.30846	.95124	.32428	838	.0513	.2419	2
59	.30874	.95115	.32460	807	.0514	.2390	1
60	.30902	.95106	.32492	3.0777	1.0515	3.2361	0

M	Sen.	Cos.	Sen.	Col.	Ton.	Col.	Sec.	M
0	94552	94533	94467	94471	94791	94447	94447	0
1	94552	94465	94467	94471	94791	94447	94447	1
2	94552	94465	94467	94471	94791	94447	94447	2
3	94552	94465	94467	94471	94791	94447	94447	3
4	94552	94465	94467	94471	94791	94447	94447	4
5	94552	94465	94467	94471	94791	94447	94447	5
6	94552	94465	94467	94471	94791	94447	94447	6
7	94552	94465	94467	94471	94791	94447	94447	7
8	94552	94465	94467	94471	94791	94447	94447	8
9	94552	94465	94467	94471	94791	94447	94447	9
10	94552	94465	94467	94471	94791	94447	94447	10
11	94552	94465	94467	94471	94791	94447	94447	11
12	94552	94465	94467	94471	94791	94447	94447	12
13	94552	94465	94467	94471	94791	94447	94447	13
14	94552	94465	94467	94471	94791	94447	94447	14
15	94552	94465	94467	94471	94791	94447	94447	15
16	94552	94465	94467	94471	94791	94447	94447	16
17	94552	94465	94467	94471	94791	94447	94447	17
18	94552	94465	94467	94471	94791	94447	94447	18
19	94552	94465	94467	94471	94791	94447	94447	19
20	94552	94465	94467	94471	94791	94447	94447	20
21	94552	94465	94467	94471	94791	94447	94447	21
22	94552	94465	94467	94471	94791	94447	94447	22
23	94552	94465	94467	94471	94791	94447	94447	23
24	94552	94465	94467	94471	94791	94447	94447	24
25	94552	94465	94467	94471	94791	94447	94447	25
26	94552	94465	94467	94471	94791	94447	94447	26
27	94552	94465	94467	94471	94791	94447	94447	27
28	94552	94465	94467	94471	94791	94447	94447	28
29	94552	94465	94467	94471	94791	94447	94447	29
30	94552	94465	94467	94471	94791	94447	94447	30
31	94552	94465	94467	94471	94791	94447	94447	31
32	94552	94465	94467	94471	94791	94447	94447	32
33	94552	94465	94467	94471	94791	94447	94447	33
34	94552	94465	94467	94471	94791	94447	94447	34
35	94552	94465	94467	94471	94791	94447	94447	35
36	94552	94465	94467	94471	94791	94447	94447	36
37	94552	94465	94467	94471	94791	94447	94447	37
38	94552	94465	94467	94471	94791	94447	94447	38
39	94552	94465	94467	94471	94791	94447	94447	39
40	94552	94465	94467	94471	94791	94447	94447	40
41	94552	94465	94467	94471	94791	94447	94447	41
42	94552	94465	94467	94471	94791	94447	94447	42
43	94552	94465	94467	94471	94791	94447	94447	43
44	94552	94465	94467	94471	94791	94447	94447	44
45	94552	94465	94467	94471	94791	94447	94447	45
46	94552	94465	94467	94471	94791	94447	94447	46
47	94552	94465	94467	94471	94791	94447	94447	47
48	94552	94465	94467	94471	94791	94447	94447	48
49	94552	94465	94467	94471	94791	94447	94447	49
50	94552	94465	94467	94471	94791	94447	94447	50
51	94552	94465	94467	94471	94791	94447	94447	51
52	94552	94465	94467	94471	94791	94447	94447	52
53	94552	94465	94467	94471	94791	94447	94447	53
54	94552	94465	94467	94471	94791	94447	94447	54
55	94552	94465	94467	94471	94791	94447	94447	55
56	94552	94465	94467	94471	94791	94447	94447	56
57	94552	94465	94467	94471	94791	94447	94447	57
58	94552	94465	94467	94471	94791	94447	94447	58
59	94552	94465	94467	94471	94791	94447	94447	59
60	94552	94465	94467	94471	94791	94447	94447	60

M	Sen.	Cos.	Sen.	Col.	Ton.	Col.	Sec.	M
0	30902	95106	32492	32492	30777	1.0515	3.2361	60
1	30929	95097	32524	32524	30746	1.0516	3.2332	59
2	30957	95088	32556	32556	30716	1.0517	3.2303	58
3	30985	95079	32588	32588	30686	1.0518	3.2274	57
4	31012	95070	32621	32621	30655	1.0519	3.2245	56
5	31040	95061	32653	32653	30625	1.0520	3.2216	55
6	31068	95051	32685	32685	30595	1.0521	3.2186	54
7	31095	95042	32717	32717	30565	1.0522	3.2159	53
8	31123	95033	32749	32749	30535	1.0523	3.2131	52
9	31150	95024	32782	32782	30505	1.0524	3.2102	51
10	31178	95015	32814	32814	30475	1.0525	3.2074	50
11	31206	95006	32846	32846	30445	1.0526	3.2045	49
12	31233	94997	32878	32878	30415	1.0527	3.2017	48
13	31261	94988	32910	32910	30385	1.0528	3.1989	47
14	31289	94979	32943	32943	30356	1.0529	3.1960	46
15	31316	94970	32975	32975	30326	1.0530	3.1932	45
16	31344	94961	33007	33007	30296	1.0531	3.1904	44
17	31372	94952	33039	33039	30267	1.0532	3.1876	43
18	31399	94942	33072	33072	30237	1.0533	3.1848	42
19	31427	94933	33104	33104	30208	1.0534	3.1820	41
20	31454	94924	33136	33136	30178	1.0535	3.1792	40
21	31482	94915	33169	33169	30149	1.0536	3.1764	39
22	31510	94906	33201	33201	30120	1.0537	3.1736	38
23	31537	94897	33233	33233	30090	1.0538	3.1708	37
24	31565	94888	33265	33265	30061	1.0539	3.1681	36
25	31592	94878	33298	33298	30032	1.0540	3.1653	35
26	31620	94869	33330	33330	30003	1.0541	3.1625	34
27	31648	94860	33362	33362	29974	1.0542	3.1598	33
28	31675	94851	33395	33395	29945	1.0543	3.1570	32
29	31703	94842	33427	33427	29916	1.0544	3.1543	31
30	31730	94832	33459	33459	29887	1.0545	3.1515	30
31	31758	94823	33492	33492	29858	1.0546	3.1488	29
32	31786	94814	33524	33524	29829	1.0547	3.1461	28
33	31813	94805	33557	33557	29800	1.0548	3.1433	27
34	31841	94795	33589	33589	29772	1.0549	3.1406	26
35	31868	94786	33621	33621	29743	1.0550	3.1379	25
36	31896	94777	33654	33654	29714	1.0551	3.1352	24
37	31923	94767	33686	33686	29686	1.0552	3.1325	23
38	31951	94758	33718	33718	29657	1.0553	3.1298	22
39	31978	94749	33751	33751	29629	1.0554	3.1271	21
40	32006	94740	33783	33783	29600	1.0555	3.1244	20
41	32034	94730	33816	33816	29572	1.0556	3.1217	19
42	32061	94722	33848	33848	29544	1.0557	3.1190	18
43	32089	94712	33880	33880	29515	1.0558	3.1163	17
44	32116	94702	33913	33913	29487	1.0559	3.1137	16
45	32144	94693	33945	33945	29458	1.0560	3.1110	15
46	32171	94684	33978	33978	29431	1.0561	3.1083	14
47	32199	94674	34010	34010	29403	1.0562	3.1057	13
48	32226	94665	34043	34043	29375	1.0563	3.1030	12
49	32254	94655	34075	34075	29347	1.0564	3.1004	11
50	32282	94646	34108	34108	29319	1.0565	3.0977	10
51	32309	94637	34140	34140	29291	1.0567	3.0951	9
52	32337	94627	34173	34173	29263	1.0568	3.0925	8
53	32364	94618	34205	34205	29235	1.0569	3.0898	7
54	32392	94608	34238	34238	29208	1.0570	3.0872	6
55	32419	94599	34270	34270	29180	1.0571	3.0846	5
56	32447	94590	34303	34303	29152	1.0572	3.0820	4
57	32474	94580	34335	34335	29125	1.0573	3.0793	3
58	32502	94571	34368	34368	29097	1.0574	3.0767	2
59	32529	94561	34400	34400	29069	1.0575	3.0741	1
60	32557	94552	34433	34433	29042	1.0576	3.0715	0

M	Sen.	Cos.	Tan.	Cot.	Sec.	Csc.	M
0	34202	93969	36397	2.7475	1.0642	2.9238	60
1	34229	93959	36430	2.7450	0.643	.9215	59
2	34257	93949	36463	2.7425	0.644	.9191	58
3	34284	93939	36496	2.7400	0.645	.9168	57
4	34311	93929	36529	2.7376	0.646	.9145	56
5	34339	93919	36562	2.7351	1.0647	2.9122	55
6	34366	93909	36595	2.7326	0.648	.9098	54
7	34393	93899	36628	2.7302	0.650	.9075	53
8	34421	93889	36661	2.7277	0.651	.9052	52
9	34448	93879	36694	2.7252	0.652	.9029	51
10	34475	93869	36727	2.7228	1.0653	2.9006	50
11	34502	93859	36760	2.7204	0.654	.8983	49
12	34530	93849	36793	2.7179	0.655	.8960	48
13	34557	93839	36826	2.7155	0.656	.8937	47
14	34584	93829	36859	2.7130	0.658	.8915	46
15	34612	93819	36892	2.7106	1.0659	2.8892	45
16	34639	93809	36925	2.7082	0.660	.8869	44
17	34666	93799	36958	2.7058	0.661	.8846	43
18	34693	93789	36991	2.7033	0.662	.8824	42
19	34721	93779	37024	2.7009	0.663	.8801	41
20	34748	93769	37057	2.6985	1.0664	2.8778	40
21	34775	93758	37090	2.6961	0.666	.8756	39
22	34803	93748	37123	2.6937	0.667	.8733	38
23	34830	93738	37156	2.6913	0.668	.8711	37
24	34857	93728	37190	2.6889	0.669	.8688	36
25	34884	93718	37223	2.6865	1.0670	2.8666	35
26	34912	93708	37256	2.6841	0.671	.8644	34
27	34939	93698	37289	2.6817	0.673	.8621	33
28	34966	93687	37322	2.6794	0.674	.8599	32
29	34993	93677	37355	2.6770	0.675	.8577	31
30	35021	93667	37388	2.6746	1.0676	2.8554	30
31	35048	93657	37422	2.6722	0.677	.8532	29
32	35075	93647	37455	2.6699	0.678	.8510	28
33	35102	93637	37488	2.6675	0.679	.8488	27
34	35130	93626	37521	2.6652	0.681	.8466	26
35	35157	93616	37554	2.6628	1.0682	2.8444	25
36	35184	93606	37587	2.6604	0.683	.8422	24
37	35211	93596	37621	2.6581	0.684	.8400	23
38	35239	93585	37654	2.6558	0.685	.8378	22
39	35266	93575	37687	2.6534	0.686	.8356	21
40	35293	93565	37720	2.6511	1.0688	2.8334	20
41	35320	93555	37754	2.6487	0.689	.8312	19
42	35347	93544	37787	2.6464	0.690	.8290	18
43	35375	93534	37820	2.6441	0.691	.8269	17
44	35402	93524	37853	2.6418	0.692	.8247	16
45	35429	93513	37887	2.6394	1.0694	2.8225	15
46	35456	93503	37920	2.6371	0.695	.8204	14
47	35483	93493	37953	2.6348	0.696	.8182	13
48	35511	93482	37986	2.6325	0.697	.8160	12
49	35538	93472	38020	2.6302	0.698	.8139	11
50	35565	93462	38053	2.6279	1.0699	2.8117	10
51	35592	93451	38086	2.6256	0.701	.8096	9
52	35619	93441	38120	2.6233	0.702	.8074	8
53	35647	93431	38153	2.6210	0.703	.8053	7
54	35674	93420	38186	2.6187	0.704	.8032	6
55	35701	93410	38220	2.6164	1.0705	2.8010	5
56	35728	93400	38253	2.6142	0.707	.7989	4
57	35755	93389	38286	2.6119	0.708	.7968	3
58	35782	93379	38320	2.6096	0.709	.7947	2
59	35810	93368	38353	2.6073	0.710	.7925	1
60	35837	93358	38386	2.6051	1.0711	2.7904	0

M	Sen.	Cos.	Tan.	Cot.	Sec.	Csc.	M
0	35837	93358	38386	2.6051	1.0711	2.7904	60
1	35864	93348	38420	6028	.0713	.7883	59
2	35891	93337	38453	6006	.0714	.7862	58
3	35918	93327	38486	5983	.0715	.7841	57
4	35945	93316	38520	5960	.0716	.7820	56
5	35972	93306	38553	2.5938	1.0717	2.7799	55
6	36000	93295	38587	5916	.0719	.7778	54
7	36027	93285	38620	5893	.0720	.7757	53
8	36054	93274	38654	5871	.0721	.7736	52
9	36081	93264	38687	5848	.0722	.7715	51
10	36108	93253	38720	2.5826	1.0723	2.7694	50
11	36135	93243	38754	5804	.0725	.7674	49
12	36162	93232	38787	5781	.0726	.7653	48
13	36189	93222	38821	5759	.0727	.7632	47
14	36217	93211	38854	5737	.0728	.7611	46
15	36244	93201	38888	2.5715	1.0729	2.7591	45
16	36271	93190	38921	5693	.0731	.7570	44
17	36298	93180	38955	5671	.0732	.7550	43
18	36325	93169	38988	5649	.0733	.7529	42
19	36352	93158	39022	5627	.0734	.7509	41
20	36379	93148	39055	2.5605	1.0736	2.7488	40
21	36406	93137	39089	5583	.0737	.7468	39
22	36433	93127	39122	5561	.0738	.7447	38
23	36460	93116	39156	5539	.0739	.7427	37
24	36488	93105	39189	5517	.0740	.7406	36
25	36515	93095	39223	2.5495	1.0742	2.7386	35
26	36542	93084	39257	5473	.0743	.7366	34
27	36569	93074	39290	5451	.0744	.7346	33
28	36596	93063	39324	5430	.0745	.7325	32
29	36623	93052	39357	5408	.0747	.7305	31
30	36650	93042	39391	2.5386	1.0748	2.7285	30
31	36677	93031	39425	5365	.0749	.7265	29
32	36704	93020	39458	5343	.0750	.7245	28
33	36731	93010	39492	5322	.0751	.7225	27
34	36758	92999	39525	5300	.0753	.7205	26
35	36785	92988	39559	2.5278	1.0754	2.7185	25
36	36812	92978	39593	5257	.0755	.7165	24
37	36839	92967	39626	5236	.0756	.7145	23
38	36866	92956	39660	5214	.0758	.7125	22
39	36893	92945	39694	5193	.0759	.7105	21
40	36921	92935	39727	2.5171	1.0760	2.7085	20
41	36948	92924	39761	5150	.0761	.7065	19
42	36975	92913	39795	5129	.0763	.7045	18
43	37002	92902	39828	5108	.0764	.7026	17
44	37029	92892	39862	5086	.0765	.7006	16
45	37056	92881	39896	2.5065	1.0766	2.6986	15
46	37083	92870	39930	5064	.0768	.6967	14
47	37110	92859	39963	5043	.0769	.6947	13
48	37137	92848	39997	5022	.0770	.6927	12
49	37164	92838	40031	4981	.0771	.6908	11
50	37191	92827	40065	2.4960	1.0773	2.6888	10
51	37218	92816	40098	4939	.0774	.6869	9
52	37245	92805	40132	4918	.0775	.6849	8
53	37272	92794	40166	4897	.0776	.6830	7
54	37299	92784	40200	4876	.0778	.6810	6
55	37326	92773	40233	2.4855	1.0779	2.6791	5
56	37353	92762	40267	4834	.0780	.6772	4
57	37380	92751	40301	4813	.0781	.6752	3
58	37407	92740	40335	4792	.0783	.6733	2
59	37434	92729	40369	4772	.0784	.6714	1
60	37461	92718	40403	2.4751	1.0785	2.6695	0

M	Cos.	Sen.	Cot.	Tan.	Csc.	Sec.	M
---	------	------	------	------	------	------	---

M	Sen	Cos	Tan	Col	Sec	Csc	Sec	Csc	M
0	37467	92718	40493	74751	1.0785	2.6695	60		
1	37488	92707	40436	74730	1.0787	6675	59		
2	37514	92686	40470	4709	0.7868	6656	58		
3	37541	92666	40504	4689	0.7899	6637	57		
4	37568	92645	40538	4668	0.7930	6618	56		
5	37595	92624	40572	4647	0.7962	6599	55		
6	37622	92603	40606	4627	0.7993	6580	54		
7	37649	92582	40640	4606	0.8024	6561	53		
8	37676	92561	40674	4585	0.8055	6542	52		
9	37703	92540	40707	4565	0.8087	6523	51		
10	37730	92519	40741	4545	0.8118	6504	50		
11	37757	92498	40775	4525	0.8149	6485	49		
12	37784	92477	40809	4505	0.8181	6466	48		
13	37811	92456	40843	4484	0.8212	6447	47		
14	37838	92435	40877	4463	0.8243	6428	46		
15	37865	92414	40911	4443	0.8274	6410	45		
16	37892	92393	40945	4423	0.8305	6391	44		
17	37919	92372	40979	4403	0.8336	6372	43		
18	37946	92351	41013	4383	0.8367	6353	42		
19	37973	92330	41047	4362	0.8398	6334	41		
20	37999	92309	41081	4342	0.8429	6315	40		
21	38026	92288	41115	4322	0.8460	6296	39		
22	38053	92267	41149	4302	0.8491	6277	38		
23	38080	92246	41183	4282	0.8522	6258	37		
24	38107	92225	41217	4262	0.8553	6239	36		
25	38134	92204	41251	4242	0.8584	6220	35		
26	38161	92183	41285	4222	0.8615	6201	34		
27	38188	92162	41319	4202	0.8646	6182	33		
28	38214	92141	41353	4182	0.8677	6163	32		
29	38241	92120	41387	4162	0.8708	6144	31		
30	38268	92099	41421	4142	0.8739	6125	30		
31	38295	92078	41455	4122	0.8770	6106	29		
32	38322	92057	41489	4102	0.8801	6087	28		
33	38349	92036	41524	4082	0.8832	6068	27		
34	38376	92015	41558	4063	0.8863	6049	26		
35	38403	92003	41592	4043	0.8894	6030	25		
36	38430	91982	41626	4023	0.8925	6011	24		
37	38457	91961	41660	4003	0.8956	5992	23		
38	38484	91940	41694	3984	0.8987	5973	22		
39	38510	91919	41728	3964	0.9018	5954	21		
40	38537	91898	41762	3945	0.9049	5935	20		
41	38564	91877	41796	3925	0.9080	5916	19		
42	38591	91856	41830	3905	0.9111	5897	18		
43	38618	91835	41864	3885	0.9142	5878	17		
44	38645	91814	41898	3865	0.9173	5859	16		
45	38672	91793	41932	3845	0.9204	5840	15		
46	38699	91772	41966	3825	0.9235	5821	14		
47	38726	91751	42000	3805	0.9266	5802	13		
48	38753	91730	42034	3785	0.9297	5783	12		
49	38780	91709	42068	3765	0.9328	5764	11		
50	38807	91688	42102	3745	0.9359	5745	10		
51	38834	91667	42136	3725	0.9390	5726	9		
52	38861	91646	42170	3705	0.9421	5707	8		
53	38888	91625	42204	3685	0.9452	5688	7		
54	38915	91604	42238	3665	0.9483	5669	6		
55	38942	91583	42272	3645	0.9514	5650	5		
56	38969	91562	42306	3625	0.9545	5631	4		
57	38996	91541	42340	3605	0.9576	5612	3		
58	39023	91520	42374	3585	0.9607	5593	2		
59	39050	91499	42408	3565	0.9638	5574	1		
60	39073	91478	42442	3545	0.9669	5555	0		

M	Sen	Cos	Tan	Col	Sec	Csc	Sec	Csc	M
0	39073	91478	42442	3545	0.9669	2.5599	60		
1	39100	91457	42476	3525	0.9700	5535	59		
2	39127	91436	42510	3505	0.9731	5516	58		
3	39154	91415	42544	3485	0.9762	5497	57		
4	39181	91394	42578	3465	0.9793	5478	56		
5	39208	91373	42612	3445	0.9824	5459	55		
6	39235	91352	42646	3425	0.9855	5440	54		
7	39262	91331	42680	3405	0.9886	5421	53		
8	39289	91310	42714	3385	0.9917	5402	52		
9	39316	91289	42748	3365	0.9948	5383	51		
10	39343	91268	42782	3345	0.9979	5364	50		
11	39370	91247	42816	3325	1.0010	5345	49		
12	39397	91226	42850	3305	1.0041	5326	48		
13	39424	91205	42884	3285	1.0072	5307	47		
14	39451	91184	42918	3265	1.0103	5288	46		
15	39478	91163	42952	3245	1.0134	5269	45		
16	39505	91142	42986	3225	1.0165	5250	44		
17	39532	91121	43020	3205	1.0196	5231	43		
18	39559	91100	43054	3185	1.0227	5212	42		
19	39586	91079	43088	3165	1.0258	5193	41		
20	39613	91058	43122	3145	1.0289	5174	40		
21	39640	91037	43156	3125	1.0320	5155	39		
22	39667	91016	43190	3105	1.0351	5136	38		
23	39694	90995	43224	3085	1.0382	5117	37		
24	39721	90974	43258	3065	1.0413	5098	36		
25	39748	90953	43292	3045	1.0444	5079	35		
26	39775	90932	43326	3025	1.0475	5060	34		
27	39802	90911	43360	3005	1.0506	5041	33		
28	39829	90890	43394	2985	1.0537	5022	32		
29	39856	90869	43428	2965	1.0568	5003	31		
30	39883	90848	43462	2945	1.0599	4984	30		
31	39910	90827	43496	2925	1.0630	4965	29		
32	39937	90806	43530	2905	1.0661	4946	28		
33	39964	90785	43564	2885	1.0692	4927	27		
34	39991	90764	43598	2865	1.0723	4908	26		
35	40018	90743	43632	2845	1.0754	4889	25		
36	40045	90722	43666	2825	1.0785	4870	24		
37	40072	90701	43700	2805	1.0816	4851	23		
38	40099	90680	43734	2785	1.0847	4832	22		
39	40126	90659	43768	2765	1.0878	4813	21		
40	40153	90638	43802	2745	1.0909	4794	20		
41	40180	90617	43836	2725	1.0940	4775	19		
42	40207	90596	43870	2705	1.0971	4756	18		
43	40234	90575	43904	2685	1.1002	4737	17		
44	40261	90554	43938	2665	1.1033	4718	16		
45	40288	90533	43972	2645	1.1064	4699	15		
46	40315	90512	44006	2625	1.1095	4680	14		
47	40342	90491	44040	2605	1.1126	4661	13		
48	40369	90470	44074	2585	1.1157	4642	12		
49	40396	90449	44108	2565	1.1188	4623	11		
50	40423	90428	44142	2545	1.1219	4604	10		
51	40450	90407	44176	2525	1.1250	4585	9		
52	40477	90386	44210	2505	1.1281	4566	8		
53	40504	90365	44244	2485	1.1312	4547	7		
54	40531	90344	44278	2465	1.1343	4528	6		
55	40558	90323	44312	2445	1.1374	4509	5		
56	40585	90302	44346	2425	1.1405	4490	4		
57	40612	90281	44380	2405	1.1436	4471	3		
58	40639	90260	44414	2385	1.1467	4452	2		
59	40666	90239	44448	2365	1.1498	4433	1		
60	40693	90218	44482	2345	1.1529	4414	0		

24°

M	Sen.	Cos.	Tan.	Cot.	Sec.	Csc.	M
0	40674	91354	44523	2.2460	1.0946	2.4585	60
1	40700	91343	44558	2443	0948	4570	59
2	40727	91331	44593	2425	0949	4554	58
3	40753	91319	44627	2408	0951	4538	57
4	40780	91307	44662	2390	0952	4522	56
5	40806	91295	44697	2.2373	1.0953	2.4506	55
6	40833	91283	44732	2355	0955	4490	54
7	40860	91271	44767	2338	0956	4474	53
8	40886	91260	44802	2320	0958	4458	52
9	40913	91248	44837	2303	0959	4442	51
10	40939	91236	44872	2.2286	1.0961	2.4426	50
11	40966	91224	44907	2268	0962	4411	49
12	40992	91212	44942	2251	0963	4395	48
13	41019	91200	44977	2234	0965	4379	47
14	41045	91188	45012	2216	0966	4363	46
15	41072	91176	45047	2.2199	1.0968	2.4347	45
16	41098	91164	45082	2182	0969	4332	44
17	41125	91152	45117	2165	0971	4316	43
18	41151	91140	45152	2147	0972	4300	42
19	41178	91128	45187	2130	0973	4285	41
20	41204	91116	45222	2.2113	1.0975	2.4269	40
21	41231	91104	45257	2096	0976	4254	39
22	41257	91092	45292	2079	0978	4238	38
23	41284	91080	45327	2062	0979	4222	37
24	41310	91068	45362	2045	0981	4207	36
25	41337	91056	45397	2.2028	1.0982	2.4191	35
26	41363	91044	45432	2011	0984	4176	34
27	41390	91032	45467	1994	0985	4160	33
28	41416	91020	45502	1977	0986	4145	32
29	41443	91008	45537	1960	0988	4130	31
30	41469	90996	45573	2.1943	1.0989	2.4114	30
31	41496	90984	45608	1926	0991	4099	29
32	41522	90972	45643	1909	0992	4083	28
33	41549	90960	45678	1892	0994	4068	27
34	41575	90948	45713	1875	0995	4053	26
35	41602	90936	45748	2.1859	1.0997	2.4037	25
36	41628	90924	45783	1842	0998	4022	24
37	41654	90911	45819	1825	1000	4007	23
38	41681	90899	45854	1808	1001	3992	22
39	41707	90887	45889	1792	1003	3976	21
40	41734	90875	45924	2.1775	1.1004	2.3961	20
41	41760	90863	45960	1758	1005	3946	19
42	41787	90851	45995	1741	1007	3931	18
43	41813	90839	46030	1725	1008	3916	17
44	41839	90826	46065	1708	1010	3901	16
45	41866	90814	46101	2.1692	1.1011	2.3886	15
46	41892	90802	46136	1675	1013	3871	14
47	41919	90790	46171	1658	1014	3856	13
48	41945	90778	46206	1642	1016	3841	12
49	41972	90765	46242	1625	1017	3826	11
50	41998	90753	46277	2.1609	1.1019	2.3811	10
51	42024	90741	46312	1592	1020	3796	9
52	42051	90729	46348	1576	1022	3781	8
53	42077	90717	46383	1559	1023	3766	7
54	42103	90704	46418	1543	1025	3751	6
55	42130	90692	46454	2.1527	1.1026	2.3736	5
56	42156	90680	46489	1510	1028	3721	4
57	42183	90668	46524	1494	1029	3706	3
58	42209	90655	46560	1478	1031	3691	2
59	42235	90643	46595	1461	1032	3677	1
60	42262	90631	46631	2.1445	1.1034	2.3662	0

65°

25°

M	Sen.	Cos.	Tan.	Col.	Sec.	Csc.	M
0	.42262	90631	46631	2.1445	1.1034	2.3662	60
1	.42288	90618	46666	.1429	.1035	.3647	59
2	.42314	90606	46702	.1412	.1037	.3632	58
3	.42341	90594	46737	.1396	.1038	.3618	57
4	.42367	90581	46772	.1380	.1040	.3603	56
5	.42394	90569	46808	2.1364	1.1041	2.3588	55
6	.42420	90557	46843	.1348	.1043	.3574	54
7	.42446	90544	46879	.1331	.1044	.3559	53
8	.42473	90532	46914	.1315	.1046	.3544	52
9	.42499	90520	46950	.1299	.1047	.3530	51
10	.42525	90507	46985	2.1283	1.1049	2.3515	50
11	.42552	90495	47021	.1267	.1050	.3501	49
12	.42578	90483	47056	.1251	.1052	.3486	48
13	.42604	90470	47092	.1235	.1053	.3472	47
14	.42630	90458	47127	.1219	.1055	.3457	46
15	.42657	90445	47163	2.1203	1.1056	2.3443	45
16	.42683	90433	47199	.1187	.1058	.3428	44
17	.42709	90421	47234	.1171	.1059	.3414	43
18	.42736	90408	47270	.1155	.1061	.3399	42
19	.42762	90396	47305	.1139	.1062	.3385	41
20	.42788	90383	47341	2.1123	1.1064	2.3371	40
21	.42815	90371	47376	.1107	.1065	.3356	39
22	.42841	90358	47412	.1092	.1067	.3342	38
23	.42867	90346	47448	.1076	.1068	.3328	37
24	.42893	90333	47483	.1060	.1070	.3313	36
25	.42920	90321	47519	2.1044	1.1072	2.3299	35
26	.42946	90308	47555	.1028	.1073	.3285	34
27	.42972	90296	47590	.1013	.1075	.3271	33
28	.42998	90283	47626	.0997	.1076	.3256	32
29	.43025	90271	47662	.0981	.1078	.3242	31
30	.43051	90258	47697	2.0965	1.1079	2.3228	30
31	.43077	90246	47733	.0950	.1081	.3214	29
32	.43104	90233	47769	.0934	.1082	.3200	28
33	.43130	90221	47805	.0918	.1084	.3186	27
34	.43156	90208	47840	.0903	.1085	.3172	26
35	.43182	90196	47876	2.0887	1.1087	2.3158	25
36	.43208	90183	47912	.0872	.1088	.3143	24
37	.43235	90171	47948	.0856	.1090	.3129	23
38	.43261	90158	47983	.0840	.1092	.3115	22
39	.43287	90145	48019	.0825	.1093	.3101	21
40	.43313	90133	48055	2.0809	1.1095	2.3087	20
41	.43340	90120	48091	.0794	.1096	.3073	19
42	.43366	90108	48127	.0778	.1098	.3059	18
43	.43392	90095	48162	.0763	.1099	.3046	17
44	.43418	90082	48198	.0747	.1101	.3032	16
45	.43444	90070	48234	2.0732	1.1102	2.3018	15
46	.43471	90057	48270	.0717	.1104	.3004	14
47	.43497	90044	48306	.0701	.1106	.2990	13
48	.43523	90032	48342	.0686	.1107	.2976	12
49	.43549	90019	48378	.0671	.1109	.2962	11
50	.43575	90006	48414	2.0655	1.1110	2.2949	10
51	.43602	89994	48449	.0640	.1112	.2935	9
52	.43628	89981	48485	.0625	.1113	.2921	8
53	.43654	89968	48521	.0609	.1115	.2907	7
54	.43680	89956	48557	.0594	.1116	.2894	6
55	.43705	89943	48593	2.0579	1.1118	2.2880	5
56	.43732	89930	48629	.0564	.1120	.2866	4
57	.43759	89918	48665	.0548	.1121	.2853	3
58	.43785	89905	48701	.0533	.1123	.2839	2
59	.43811	89892	48737	.0518	.1124	.2825	1
60	.43837	89879	48773	2.0503	1.1126	2.2812	0

64°

M	Sen.	Cos.	Sen.	Col.	Ton.	Cos.	Sec.	M
0	45399	89101	50952	1	9616	1	1223	2 2027
1	45425	89087	50989		9612		1225	2014
2	45451	89074	51026		9598		1226	2002
3	45477	89061	51062		9584		1228	1989
4	45503	89048	51099		9570		1230	1977
5	45528	89034	51136	1	9556	1	1231	2 1964
6	45554	89021	51172		9542		1233	1952
7	45580	89008	51209		9528		1235	1939
8	45606	88995	51246		9514		1237	1927
9	45632	88981	51283		9500		1238	1914
10	45658	88968	51319	1	9486	1	1240	2 1902
11	45684	88955	51356		9472		1242	1889
12	45710	88942	51393		9458		1243	1877
13	45735	88928	51430		9444		1245	1865
14	45761	88915	51466	1	9430	1	1247	1852
15	45787	88902	51503		9416		1248	2 1840
16	45813	88888	51540		9402		1250	1828
17	45839	88875	51577		9388		1252	1815
18	45865	88862	51614		9375		1253	1803
19	45891	88848	51651	1	9361	1	1255	1791
20	45917	88835	51687		9347		1 1257	2 1778
21	45942	88822	51724		9333		1258	1766
22	45968	88808	51761		9319		1260	1754
23	45994	88795	51798		9306		1262	1742
24	46020	88781	51835	1	9292	1	1264	1730
25	46046	88768	51872		9278		1265	1717
26	46072	88755	51909		9264		1267	1705
27	46097	88741	51946		9251		1269	1693
28	46123	88728	51983		9237		1270	1681
29	46149	88714	52020	1	9223	1	1272	2 1669
30	46175	88701	52057		9210		1274	2 1657
31	46201	88688	52094		9196		1275	1645
32	46226	88674	52131		9182		1277	1633
33	46252	88661	52168		9169		1279	1620
34	46278	88647	52205		9155		1281	1608
35	46304	88634	52242	1	9142	1	1282	2 1596
36	46330	88620	52279		9128		1284	1584
37	46355	88607	52316		9115		1286	1572
38	46381	88593	52353		9101		1287	1560
39	46407	88580	52390		9088		1289	1548
40	46433	88566	52427	1	9074	1	1291	2 1536
41	46458	88553	52464		9061		1293	1525
42	46484	88539	52501		9047		1294	1513
43	46510	88526	52538		9034		1296	1501
44	46536	88512	52575		9020		1298	1489
45	46561	88499	52612	1	9007	1	1299	2 1477
46	46587	88485	52650		8993		1301	1465
47	46613	88472	52687		8980		1303	1453
48	46639	88458	52724		8967		1305	1441
49	46664	88444	52761	1	8953	1	1306	2 1430
50	46690	88431	52798		8940		1 1308	2 1418
51	46716	88417	52836		8927		1310	1406
52	46741	88404	52873		8913		1312	1394
53	46767	88390	52910		8900		1313	1382
54	46793	88376	52947	1	8887	1	1315	2 1369
55	46819	88363	52984		8873		1 1317	2 1359
56	46844	88349	53022		8860		1319	1347
57	46870	88336	53059		8847		1320	1335
58	46896	88322	53096		8834		1322	1324
59	46921	88308	53134		8820		1324	1312
60	46947	88295	53171		8807		1 1326	2 1300

M	Sec.	Csc.	Tan.	Col.	Sen.	Cos.	M
0	2 2027	1 1223	1 9626	50952	89101	45399	60
1	2039	1222	9640	50916	89114	45373	59
2	2052	1220	9654	50879	89127	45347	58
3	2065	1218	9668	50843	89140	45321	57
4	2077	1217	9683	50806	89153	45295	56
5	2 2090	1 1215	1 9697	50769	89166	45269	55
6	2103	1213	9711	50733	89180	45243	54
7	2115	1212	9725	50696	89193	45217	53
8	2128	1210	9739	50660	89206	45191	52
9	2141	1208	9754	50623	89219	45166	51
10	2 2153	1 1207	1 9768	50587	89232	45140	50
11	2166	1205	9782	50550	89245	45114	49
12	2179	1203	9797	50514	89258	45088	48
13	2192	1202	9811	50477	89272	45062	47
14	2204	1200	9825	50441	89285	45036	46
15	2 2217	1 1198	1 9840	50404	89298	45010	45
16	2230	1197	9854	50368	89311	44984	44
17	2243	1195	9868	50331	89324	44958	43
18	2256	1193	9883	50295	89337	44932	42
19	2269	1192	9897	50258	89350	44906	41
20	2 2282	1 1190	1 9912	50222	89363	44880	40
21	2294	1189	9926	50185	89376	44854	39
22	2307	1187	9940	50149	89389	44828	38
23	2320	1185	9955	50113	89402	44802	37
24	2333	1184	9969	50076	89415	44776	36
25	2 2348	1 1182	1 9984	50040	89428	44750	35
26	2359	1180	1 9998	50003	89441	44724	34
27	2372	1179	10013	49967	89454	44698	33
28	2385	1177	10028	49931	89467	44672	32
29	2398	1176	10042	49894	89480	44646	31
30	2 2411	1 1174	2 0057	49858	89493	44620	30
31	2425	1172	0071	49822	89506	44594	29
32	2438	1171	0086	49785	89519	44568	28
33	2451	1169	0101	49749	89532	44542	27
34	2464	1167	0115	49713	89545	44516	26
35	2 2477	1 1166	2 0130	49677	89558	44489	25
36	2490	1164	0145	49640	89571	44463	24
37	2503	1163	0159	49604	89584	44437	23
38	2517	1161	0174	49568	89597	44411	22
39	2530	1159	0189	49532	89610	44385	21
40	2 2543	1 1158	2 0204	49495	89623	44359	20
41	2556	1156	0219	49459	89636	44333	19
42	2570	1155	0233	49423	89649	44307	18
43	2583	1153	0248	49387	89661	44281	17
44	2596	1151	0263	49351	89674	44255	16
45	2 2610	1 1150	2 0278	49314	89687	44229	15
46	2623	1148	0293	49278	89700	44203	14
47	2636	1147	0308	49242	89713	44177	13
48	2650	1145	0323	49206	89726	44150	12
49	2663	1143	0338	49170	89739	44124	11
50	2 2676	1 1142	2 0352	49134	89751	44098	10
51	2690	1140	0367	49098	89764	44072	9
52	2703	1139	0382	49062	89777	44046	8
53	2717	1137	0397	49025	89790	44020	7
54	2730	1135	0412	48989	89803	43994	6
55	2 2744	1 1134	2 0427	48953	89815	43968	5
56	2757	1132	0443	48917	89828	43942	4
57	2771	1131	0458	48881	89841	43915	3
58	2784	1129	0473	48845	89854	43889	2
59	2798	1127	0488	48809	89867	43863	1
60	2 2812	1 1126	2 0503	48773	89879	43837	0

M	Sen.	Cos.	Tan.	Cot.	Sec.	Csc.	M
0	.46947	.88295	.53171	1.8807	1.1326	2.1300	60
1	.46973	.88281	.53208	.8794	.1327	.1289	59
2	.46998	.88267	.53245	.8781	.1329	.1277	58
3	.47024	.88254	.53283	.8768	.1331	.1266	57
4	.47050	.88240	.53320	.8754	.1333	.1254	56
5	.47075	.88226	.53358	1.8741	1.1334	2.1242	55
6	.47101	.88213	.53395	.8728	.1336	.1231	54
7	.47127	.88199	.53432	.8715	.1338	.1219	53
8	.47152	.88185	.53470	.8702	.1340	.1208	52
9	.47178	.88171	.53507	.8689	.1341	.1196	51
10	.47204	.88158	.53545	1.8676	1.1343	2.1185	50
11	.47229	.88144	.53582	.8663	.1345	.1173	49
12	.47255	.88130	.53619	.8650	.1347	.1162	48
13	.47281	.88117	.53657	.8637	.1349	.1150	47
14	.47306	.88103	.53694	.8624	.1350	.1139	46
15	.47332	.88089	.53732	1.8611	1.1352	2.1127	45
16	.47357	.88075	.53769	.8598	.1354	.1116	44
17	.47383	.88061	.53807	.8585	.1356	.1104	43
18	.47409	.88048	.53844	.8572	.1357	.1093	42
19	.47434	.88034	.53882	.8559	.1359	.1082	41
20	.47460	.88020	.53919	1.8546	1.1361	2.1070	40
21	.47486	.88006	.53957	.8533	.1363	.1059	39
22	.47511	.87992	.53995	.8520	.1365	.1048	38
23	.47537	.87979	.54032	.8507	.1366	.1036	37
24	.47562	.87965	.54070	.8495	.1368	.1025	36
25	.47588	.87951	.54107	1.8482	1.1370	2.1014	35
26	.47613	.87937	.54145	.8469	.1372	.1002	34
27	.47639	.87923	.54183	.8456	.1373	.0991	33
28	.47665	.87909	.54220	.8443	.1375	.0980	32
29	.47690	.87895	.54258	.8430	.1377	.0969	31
30	.47716	.87882	.54295	1.8418	1.1379	2.0957	30
31	.47741	.87868	.54333	.8405	.1381	.0946	25
32	.47767	.87854	.54371	.8392	.1382	.0935	28
33	.47792	.87840	.54409	.8379	.1384	.0924	27
34	.47818	.87826	.54446	.8367	.1386	.0912	26
35	.47844	.87812	.54484	1.8354	1.1388	2.0901	25
36	.47869	.87798	.54522	.8341	.1390	.0890	24
37	.47895	.87784	.54559	.8329	.1391	.0879	23
38	.47920	.87770	.54597	.8316	.1393	.0868	22
39	.47946	.87756	.54635	.8303	.1395	.0857	21
40	.47971	.87742	.54673	1.8291	1.1397	2.0846	20
41	.47997	.87728	.54711	.8278	.1399	.0835	19
42	.48022	.87715	.54748	.8265	.1401	.0824	18
43	.48048	.87701	.54786	.8253	.1402	.0812	17
44	.48073	.87687	.54824	.8240	.1404	.0801	16
45	.48099	.87673	.54862	1.8227	1.1406	2.0790	15
46	.48124	.87659	.54900	.8215	.1408	.0779	14
47	.48150	.87645	.54937	.8202	.1410	.0768	13
48	.48175	.87631	.54975	.8190	.1411	.0757	12
49	.48201	.87617	.55013	.8177	.1413	.0746	11
50	.48226	.87603	.55051	1.8165	1.1415	2.0735	10
51	.48252	.87588	.55089	.8152	.1417	.0725	9
52	.48277	.87574	.55127	.8140	.1419	.0714	8
53	.48303	.87560	.55165	.8127	.1421	.0703	7
54	.48328	.87546	.55203	.8115	.1422	.0692	6
55	.48354	.87532	.55241	1.8102	1.1424	2.0681	5
56	.48379	.87518	.55279	.8090	.1426	.0670	4
57	.48405	.87504	.55317	.8078	.1428	.0659	3
58	.48430	.87490	.55355	.8065	.1430	.0648	2
59	.48455	.87476	.55393	.8053	.1432	.0637	1
60	.48481	.87462	.55431	1.8040	1.1433	2.0627	0

M	Sen.	Cos.	Tan.	Cot.	Sec.	Cos.	M
0	48481	87462	55431	1 8040	1 1433	2.0627	60
1	48506	87448	55469	8028	1435	0616	59
2	48532	87434	55507	8016	1437	0605	58
3	48557	87420	55545	8003	1439	0594	57
4	48583	87405	55583	7991	1441	0583	56
5	48608	87391	55621	1.7979	1.1443	2.0573	55
6	48633	87377	55659	7966	1445	0562	54
7	48659	87363	55697	7954	1446	0551	53
8	48684	87349	55735	7942	1448	0540	52
9	48710	87335	55774	7930	1450	0530	51
10	48735	87320	55812	1.7917	1.1452	2.0519	50
11	48760	87306	55850	7905	1454	0508	49
12	48786	87292	55888	7893	1456	0498	48
13	48811	87278	55926	7881	1458	0487	47
14	48837	87264	55964	7868	1459	0476	46
15	48862	87250	56003	1.7856	1.1461	2.0466	45
16	48887	87235	56041	7844	1463	0455	44
17	48913	87221	56079	7832	1465	0444	43
18	48938	87207	56117	7820	1467	0434	42
19	48964	87193	56156	7808	1469	0423	41
20	48989	87178	56194	1.7795	1.1471	2.0413	40
21	49014	87164	56232	7783	1473	0402	39
22	49040	87150	56270	7771	1474	0392	38
23	49065	87136	56309	7759	1476	0381	37
24	49090	87121	56347	7747	1478	0370	36
25	49116	87107	56385	1.7735	1.1480	2.0360	35
26	49141	87093	56424	7723	1482	0349	34
27	49166	87078	56462	7711	1484	0339	33
28	49192	87064	56500	7699	1486	0329	32
29	49217	87050	56539	7687	1488	0318	31
30	49242	87035	56577	1.7675	1.1489	2.0308	30
31	49268	87021	56616	7663	1491	0297	29
32	49293	87007	56654	7651	1493	0287	28
33	49318	86992	56692	7639	1495	0276	27
34	49343	86978	56731	7627	1497	0266	26
35	49369	86964	56769	1.7615	1.1499	2.0256	25
36	49394	86949	56808	7603	1501	0245	24
37	49419	86935	56846	7591	1503	0235	23
38	49445	86921	56885	7579	1505	0224	22
39	49470	86906	56923	7567	1507	0214	21
40	49495	86892	56962	1.7555	1.1508	2.0204	20
41	49521	86877	57000	7544	1510	0194	19
42	49546	86863	57039	7532	1512	0183	18
43	49571	86849	57077	7520	1514	0173	17
44	49596	86834	57116	7508	1516	0163	16
45	49622	86820	57155	1.7496	1.1518	2.0152	15
46	49647	86805	57193	7484	1520	0142	14
47	49672	86791	57232	7473	1522	0132	13
48	49697	86776	57270	7461	1524	0122	12
49	49723	86762	57309	7449	1526	0111	11
50	49748	86748	57348	1.7437	1.1528	2.0101	10
51	49773	86733	57386	7426	1530	0091	9
52	49798	86719	57425	7414	1531	0081	8
53	49823	86704	57464	7402	1533	0071	7
54	49849	86690	57502	7390	1535	0061	6
55	49874	86675	57541	1.7379	1.1537	2.0050	5
56	49899	86661	57580	7367	1539	0040	4
57	49924	86646	57619	7355	1541	0030	3
58	49950	86632	57657	7344	1543	0020	2
59	49975	86617	57696	7332	1545	0010	1
60	50000	86603	57735	1.7320	1.1547	2.0000	0

M	Sen.	Cos.	Tan.	Col.	Sec.	Csc.	M
0	5.0000	86603	57735	1720	1647	9980	60
1	5.0025	86575	57811	1729	1649	9980	59
2	5.0050	86548	57887	1738	1650	9980	58
3	5.0075	86521	57963	1747	1651	9980	57
4	5.0101	86494	58039	1756	1652	9980	56
5	5.0126	86467	58115	1765	1653	9980	55
6	5.0151	86440	58191	1774	1654	9980	54
7	5.0176	86413	58267	1783	1655	9980	53
8	5.0201	86386	58343	1792	1656	9980	52
9	5.0226	86359	58419	1801	1657	9980	51
10	5.0251	86332	58495	1810	1658	9980	50
11	5.0276	86305	58571	1819	1659	9980	49
12	5.0301	86278	58647	1828	1660	9980	48
13	5.0326	86251	58723	1837	1661	9980	47
14	5.0351	86224	58799	1846	1662	9980	46
15	5.0376	86197	58875	1855	1663	9980	45
16	5.0401	86170	58951	1864	1664	9980	44
17	5.0426	86143	59027	1873	1665	9980	43
18	5.0451	86116	59103	1882	1666	9980	42
19	5.0476	86089	59179	1891	1667	9980	41
20	5.0501	86062	59255	1900	1668	9980	40
21	5.0526	86035	59331	1909	1669	9980	39
22	5.0551	86008	59407	1918	1670	9980	38
23	5.0576	85981	59483	1927	1671	9980	37
24	5.0601	85954	59559	1936	1672	9980	36
25	5.0626	85927	59635	1945	1673	9980	35
26	5.0651	85900	59711	1954	1674	9980	34
27	5.0676	85873	59787	1963	1675	9980	33
28	5.0701	85846	59863	1972	1676	9980	32
29	5.0726	85819	59939	1981	1677	9980	31
30	5.0751	85792	60015	1990	1678	9980	30
31	5.0776	85765	60091	1999	1679	9980	29
32	5.0801	85738	60167	2008	1680	9980	28
33	5.0826	85711	60243	2017	1681	9980	27
34	5.0851	85684	60319	2026	1682	9980	26
35	5.0876	85657	60395	2035	1683	9980	25
36	5.0901	85630	60471	2044	1684	9980	24
37	5.0926	85603	60547	2053	1685	9980	23
38	5.0951	85576	60623	2062	1686	9980	22
39	5.0976	85549	60699	2071	1687	9980	21
40	5.1001	85522	60775	2080	1688	9980	20
41	5.1026	85495	60851	2089	1689	9980	19
42	5.1051	85468	60927	2098	1690	9980	18
43	5.1076	85441	61003	2107	1691	9980	17
44	5.1101	85414	61079	2116	1692	9980	16
45	5.1126	85387	61155	2125	1693	9980	15
46	5.1151	85360	61231	2134	1694	9980	14
47	5.1176	85333	61307	2143	1695	9980	13
48	5.1201	85306	61383	2152	1696	9980	12
49	5.1226	85279	61459	2161	1697	9980	11
50	5.1251	85252	61535	2170	1698	9980	10
51	5.1276	85225	61611	2179	1699	9980	9
52	5.1301	85198	61687	2188	1700	9980	8
53	5.1326	85171	61763	2197	1701	9980	7
54	5.1351	85144	61839	2206	1702	9980	6
55	5.1376	85117	61915	2215	1703	9980	5
56	5.1401	85090	61991	2224	1704	9980	4
57	5.1426	85063	62067	2233	1705	9980	3
58	5.1451	85036	62143	2242	1706	9980	2
59	5.1476	85009	62219	2251	1707	9980	1
60	5.1500	85000	62244	2257	1708	9980	0

M	Sen.	Cos.	Tan.	Col.	Sec.	Csc.	M
0	5.1500	85717	60086	16543	1666	19416	60
1	5.1529	85742	60126	16532	1668	19407	59
2	5.1554	85767	60165	16521	1670	19398	58
3	5.1578	85792	60205	16510	1672	19388	57
4	5.1603	85817	60244	16499	1674	19378	56
5	5.1627	85842	60284	16488	1676	19368	55
6	5.1652	85867	60323	16477	1678	19358	54
7	5.1676	85892	60363	16466	1680	19348	53
8	5.1701	85917	60403	16455	1683	19338	52
9	5.1725	85942	60443	16444	1685	19328	51
10	5.1750	85967	60483	16433	1687	19318	50
11	5.1774	85992	60523	16422	1689	19308	49
12	5.1800	86017	60562	16411	1691	19298	48
13	5.1827	86042	60602	16400	1693	19288	47
14	5.1854	86067	60642	16389	1695	19278	46
15	5.1882	86092	60682	16378	1697	19268	45
16	5.1910	86117	60722	16367	1699	19258	44
17	5.1938	86142	60762	16356	1701	19248	43
18	5.1966	86167	60802	16345	1703	19238	42
19	5.1994	86192	60842	16334	1705	19228	41
20	5.2022	86217	60882	16323	1707	19218	40
21	5.2050	86242	60922	16312	1709	19208	39
22	5.2078	86267	60962	16301	1711	19198	38
23	5.2106	86292	61002	16290	1713	19188	37
24	5.2134	86317	61042	16279	1715	19178	36
25	5.2162	86342	61082	16268	1717	19168	35
26	5.2190	86367	61122	16257	1719	19158	34
27	5.2218	86392	61162	16246	1721	19148	33
28	5.2246	86417	61202	16235	1723	19138	32
29	5.2274	86442	61242	16224	1725	19128	31
30	5.2302	86467	61282	16213	1727	19118	30
31	5.2330	86492	61322	16202	1729	19108	29
32	5.2358	86517	61362	16191	1731	19098	28
33	5.2386	86542	61402	16180	1733	19088	27
34	5.2414	86567	61442	16169	1735	19078	26
35	5.2442	86592	61482	16158	1737	19068	25
36	5.2470	86617	61522	16147	1739	19058	24
37	5.2498	86642	61562	16136	1741	19048	23
38	5.2526	86667	61602	16125	1743	19038	22
39	5.2554	86692	61642	16114	1745	19028	21
40	5.2582	86717	61682	16103	1747	19018	20
41	5.2610	86742	61722	16092	1749	19008	19
42	5.2638	86767	61762	16081	1751	19000	18
43	5.2666	86792	61802	16070	1753	18990	17
44	5.2694	86817	61842	16059	1755	18980	16
45	5.2722	86842	61882	16048	1757	18970	15
46	5.2750	86867	61922	16037	1759	18960	14
47	5.2778	86892	61962	16026	1761	18950	13
48	5.2806	86917	62002	16015	1763	18940	12
49	5.2834	86942	62042	16004	1765	18930	11
50	5.2862	86967	62082	15993	1767	18920	10
51	5.2890	86992	62122	15982	1769	18910	9
52	5.2918	87017	62162	15971	1771	18900	8
53	5.2946	87042	62202	15960	1773	18890	7
54	5.2974	87067	62242	15949	1775	18880	6
55	5.3002	87092	62282	15938	1777	18870	5
56	5.3030	87117	62322	15927	1779	18860	4
57	5.3058	87142	62362	15916	1781	18850	3
58	5.3086	87167	62402	15905	1783	18840	2
59	5.3114	87192	62442	15894	1785	18830	1
60	5.3142	87217	62482	15883	1787	18820	0

M	Sen	Cos	Tan	Col	Sec	Csk	Csk	Sec	M
0	52992	84805	62487	1.6003	1.1792	1.8871	60	59	0
1	53016	84789	62527	1.5993	1.1794	88664	60	58	1
2	53041	84774	62568	1.5983	1.1796	88533	58	57	2
3	53066	84758	62608	1.5972	1.1798	88444	57	56	3
4	53091	84743	62649	1.5962	1.1800	88356	56	55	4
5	53115	84728	62690	1.5952	1.1802	88272	55	54	5
6	53140	84712	62730	1.5943	1.1805	88188	54	53	6
7	53164	84697	62770	1.5934	1.1808	88105	53	52	7
8	53189	84681	62811	1.5925	1.1809	88021	52	51	8
9	53214	84666	62852	1.5916	1.1811	87937	51	50	9
10	53238	84650	62892	1.5907	1.1813	87853	50	49	10
11	53263	84635	62933	1.5898	1.1815	87768	49	48	11
12	53288	84619	62973	1.5889	1.1818	87686	48	47	12
13	53312	84604	63014	1.5880	1.1820	87599	47	46	13
14	53337	84588	63055	1.5871	1.1822	87515	46	45	14
15	53361	84573	63096	1.5862	1.1824	87429	45	44	15
16	53386	84557	63137	1.5853	1.1826	87340	44	43	16
17	53410	84542	63177	1.5844	1.1828	87251	43	42	17
18	53435	84526	63217	1.5835	1.1831	87164	42	41	18
19	53460	84511	63258	1.5826	1.1833	87076	41	40	19
20	53484	84495	63299	1.5817	1.1835	86989	40	39	20
21	53509	84479	63339	1.5808	1.1837	86904	39	38	21
22	53533	84464	63380	1.5799	1.1839	86819	38	37	22
23	53558	84448	63421	1.5790	1.1841	86734	37	36	23
24	53583	84433	63462	1.5781	1.1843	86651	36	35	24
25	53607	84417	63503	1.5772	1.1845	86568	35	34	25
26	53632	84402	63544	1.5763	1.1847	86484	34	33	26
27	53656	84386	63584	1.5754	1.1849	86401	33	32	27
28	53681	84370	63625	1.5745	1.1852	86317	32	31	28
29	53705	84355	63666	1.5736	1.1854	86234	31	30	29
30	53730	84339	63707	1.5727	1.1857	86151	30	29	30
31	53754	84323	63748	1.5718	1.1859	86068	29	28	31
32	53779	84308	63789	1.5709	1.1861	85985	28	27	32
33	53803	84292	63830	1.5700	1.1863	85902	27	26	33
34	53828	84276	63871	1.5691	1.1865	85819	26	25	34
35	53852	84261	63912	1.5682	1.1868	85736	25	24	35
36	53877	84245	63953	1.5673	1.1870	85653	24	23	36
37	53901	84229	63994	1.5664	1.1872	85570	23	22	37
38	53926	84214	64035	1.5655	1.1874	85487	22	21	38
39	53950	84198	64076	1.5646	1.1877	85404	21	20	39
40	53975	84182	64117	1.5637	1.1879	85321	20	19	40
41	53999	84167	64158	1.5628	1.1881	85238	19	18	41
42	54024	84151	64199	1.5619	1.1883	85155	18	17	42
43	54048	84135	64240	1.5610	1.1885	85072	17	16	43
44	54073	84120	64281	1.5601	1.1888	84989	16	15	44
45	54097	84104	64322	1.5592	1.1890	84906	15	14	45
46	54122	84088	64363	1.5583	1.1892	84823	14	13	46
47	54146	84072	64404	1.5574	1.1894	84740	13	12	47
48	54171	84057	64445	1.5565	1.1897	84657	12	11	48
49	54195	84041	64487	1.5556	1.1897	84574	11	10	49
50	54220	84025	64528	1.5547	1.1901	84491	10	9	50
51	54244	84009	64569	1.5538	1.1903	84408	9	8	51
52	54268	83993	64610	1.5529	1.1905	84325	8	7	52
53	54293	83978	64652	1.5520	1.1908	84242	7	6	53
54	54317	83962	64693	1.5511	1.1910	84159	6	5	54
55	54342	83946	64734	1.5502	1.1912	84076	5	4	55
56	54366	83930	64775	1.5493	1.1914	83993	4	3	56
57	54391	83914	64817	1.5484	1.1917	83910	3	2	57
58	54415	83898	64858	1.5475	1.1919	83827	2	1	58
59	54440	83882	64899	1.5466	1.1921	83744	1	0	59
60	54464	83867	64941	1.5457	1.1924	83661	0	0	60

M	Sen	Cos	Tan	Col	Sec	Csk	Csk	Sec	M
0	54464	83867	64941	1.5457	1.1924	83661	60	59	0
1	54488	83851	64982	1.5448	1.1926	83578	59	58	1
2	54513	83835	65023	1.5439	1.1928	83495	58	57	2
3	54537	83819	65065	1.5430	1.1930	83412	57	56	3
4	54561	83804	65106	1.5421	1.1933	83329	56	55	4
5	54586	83788	65148	1.5412	1.1935	83246	55	54	5
6	54610	83772	65190	1.5403	1.1937	83163	54	53	6
7	54635	83756	65232	1.5394	1.1939	83080	53	52	7
8	54659	83740	65273	1.5385	1.1941	83000	52	51	8
9	54683	83724	65314	1.5376	1.1944	82917	51	50	9
10	54708	83708	65355	1.5367	1.1946	82834	50	49	10
11	54732	83692	65397	1.5358	1.1948	82751	49	48	11
12	54756	83676	65438	1.5349	1.1951	82668	48	47	12
13	54781	83660	65479	1.5340	1.1953	82585	47	46	13
14	54805	83644	65521	1.5331	1.1955	82502	46	45	14
15	54829	83628	65562	1.5322	1.1958	82419	45	44	15
16	54854	83612	65603	1.5313	1.1960	82336	44	43	16
17	54878	83596	65644	1.5304	1.1962	82253	43	42	17
18	54902	83580	65685	1.5295	1.1964	82170	42	41	18
19	54926	83564	65726	1.5286	1.1967	82087	41	40	19
20	54950	83548	65767	1.5277	1.1969	82004	40	39	20
21	54975	83532	65808	1.5268	1.1971	81921	39	38	21
22	54999	83517	65849	1.5259	1.1974	81838	38	37	22
23	55024	83501	65890	1.5250	1.1976	81755	37	36	23
24	55048	83485	65931	1.5241	1.1978	81672	36	35	24
25	55072	83469	65972	1.5232	1.1980	81589	35	34	25
26	55097	83453	66013	1.5223	1.1982	81506	34	33	26
27	55121	83437	66054	1.5214	1.1985	81423	33	32	27
28	55146	83421	66095	1.5205	1.1987	81340	32	31	28
29	55169	83405	66136	1.5196	1.1990	81257	31	30	29
30	55194	83389	66177	1.5187	1.1992	81174	30	29	30
31	55218	83373	66218	1.5178	1.1994	81091	29	28	31
32	55242	83357	66259	1.5169	1.1997	81008	28	27	32
33	55266	83340	66301	1.5160	1.1999	80925	27	26	33
34	55291	83324	66342	1.5151	1.2001	80842	26	25	34
35	55315	83307	66383	1.5142	1.2004	80759	25	24	35
36	55339	83291	66424	1.5133	1.2006	80676	24	23	36
37	55363	83275	66465	1.5124	1.2008	80593	23	22	37
38	55387	83259	66506	1.5115	1.2010	80510	22	21	38
39	55412	83243	66547	1.5106	1.2013	80427	21	20	39
40	55436	83227	66588	1.5097	1.2015	80344	20	19	40
41	55460	83211	66629	1.5088	1.2017	80261	19	18	41
42	55484	83195	66670	1.5079	1.2020	80178	18	17	42
43	55508	83179	66711	1.5070	1.2022	80095	17	16	43
44	55533	83163	66752	1.5061	1.2024	80012	16	15	44
45	55557	83147	66793	1.5052	1.2026	79929	15	14	45
46	55581	83131	66834	1.5043	1.2027	79846	14	13	46
47	55605	83115	66875	1.5034	1.2029	79763	13	12	47
48	55629	83099	66916	1.5025	1.2031	79680	12	11	48
49	55653	83083	66957	1.5016	1.2034	79597	11	10	49
50	55677	83067	67000	1.5007	1.2036	79514	10	9	50
51	55702	83051	67041	1.5000	1.2038	79431	9	8	51
52	55726	83035	67082	1.4991	1.2041	79348	8	7	52
53	55750	83019	67123	1.4982	1.2043	79265	7	6	53
54	55774	83003	67164	1.4973	1.2045	79182	6	5	54
55	55798	82987	67205	1.4964	1.2048	79099	5	4	55
56	55822	82971	67246	1.4955	1.2050	79016	4	3	56
57	55846	82955	67287	1.4946	1.2052	78933	3	2	57
58	55870	82939	67328	1.4937	1.2054	78850	2	1	58
59	55894	82923	67369	1.4928	1.2057	78767	1	0	59
60	55918	82907	67410	1.4919	1.2062	78684	0	0	60

35°

M	Sen.	Cos.	Tan.	Col.	Sen.	Cos.	Tan.	Col.	Sec.	Csc.	M
0	1	1.0000	0.0000	0.0000	0.0000	1.0000	0.0000	0.0000	0.0000	0.0000	0
1	0.9998	0.0174	0.0174	0.0174	0.0174	0.9998	0.0174	0.0174	0.0174	1.0000	1
2	0.9996	0.0349	0.0349	0.0349	0.0349	0.9996	0.0349	0.0349	0.0349	1.0000	2
3	0.9991	0.0523	0.0523	0.0523	0.0523	0.9991	0.0523	0.0523	0.0523	1.0000	3
4	0.9984	0.0696	0.0696	0.0696	0.0696	0.9984	0.0696	0.0696	0.0696	1.0000	4
5	0.9975	0.0868	0.0868	0.0868	0.0868	0.9975	0.0868	0.0868	0.0868	1.0000	5
6	0.9964	0.1039	0.1039	0.1039	0.1039	0.9964	0.1039	0.1039	0.1039	1.0000	6
7	0.9951	0.1209	0.1209	0.1209	0.1209	0.9951	0.1209	0.1209	0.1209	1.0000	7
8	0.9936	0.1378	0.1378	0.1378	0.1378	0.9936	0.1378	0.1378	0.1378	1.0000	8
9	0.9919	0.1546	0.1546	0.1546	0.1546	0.9919	0.1546	0.1546	0.1546	1.0000	9
10	0.9900	0.1713	0.1713	0.1713	0.1713	0.9900	0.1713	0.1713	0.1713	1.0000	10
11	0.9879	0.1879	0.1879	0.1879	0.1879	0.9879	0.1879	0.1879	0.1879	1.0000	11
12	0.9856	0.2044	0.2044	0.2044	0.2044	0.9856	0.2044	0.2044	0.2044	1.0000	12
13	0.9831	0.2208	0.2208	0.2208	0.2208	0.9831	0.2208	0.2208	0.2208	1.0000	13
14	0.9804	0.2371	0.2371	0.2371	0.2371	0.9804	0.2371	0.2371	0.2371	1.0000	14
15	0.9775	0.2533	0.2533	0.2533	0.2533	0.9775	0.2533	0.2533	0.2533	1.0000	15
16	0.9744	0.2694	0.2694	0.2694	0.2694	0.9744	0.2694	0.2694	0.2694	1.0000	16
17	0.9711	0.2854	0.2854	0.2854	0.2854	0.9711	0.2854	0.2854	0.2854	1.0000	17
18	0.9676	0.3013	0.3013	0.3013	0.3013	0.9676	0.3013	0.3013	0.3013	1.0000	18
19	0.9639	0.3171	0.3171	0.3171	0.3171	0.9639	0.3171	0.3171	0.3171	1.0000	19
20	0.9600	0.3328	0.3328	0.3328	0.3328	0.9600	0.3328	0.3328	0.3328	1.0000	20
21	0.9559	0.3484	0.3484	0.3484	0.3484	0.9559	0.3484	0.3484	0.3484	1.0000	21
22	0.9516	0.3639	0.3639	0.3639	0.3639	0.9516	0.3639	0.3639	0.3639	1.0000	22
23	0.9471	0.3793	0.3793	0.3793	0.3793	0.9471	0.3793	0.3793	0.3793	1.0000	23
24	0.9424	0.3946	0.3946	0.3946	0.3946	0.9424	0.3946	0.3946	0.3946	1.0000	24
25	0.9375	0.4098	0.4098	0.4098	0.4098	0.9375	0.4098	0.4098	0.4098	1.0000	25
26	0.9324	0.4249	0.4249	0.4249	0.4249	0.9324	0.4249	0.4249	0.4249	1.0000	26
27	0.9271	0.4400	0.4400	0.4400	0.4400	0.9271	0.4400	0.4400	0.4400	1.0000	27
28	0.9216	0.4549	0.4549	0.4549	0.4549	0.9216	0.4549	0.4549	0.4549	1.0000	28
29	0.9159	0.4700	0.4700	0.4700	0.4700	0.9159	0.4700	0.4700	0.4700	1.0000	29
30	0.9100	0.4849	0.4849	0.4849	0.4849	0.9100	0.4849	0.4849	0.4849	1.0000	30
31	0.9039	0.5000	0.5000	0.5000	0.5000	0.9039	0.5000	0.5000	0.5000	1.0000	31
32	0.8976	0.5149	0.5149	0.5149	0.5149	0.8976	0.5149	0.5149	0.5149	1.0000	32
33	0.8911	0.5300	0.5300	0.5300	0.5300	0.8911	0.5300	0.5300	0.5300	1.0000	33
34	0.8844	0.5449	0.5449	0.5449	0.5449	0.8844	0.5449	0.5449	0.5449	1.0000	34
35	0.8775	0.5600	0.5600	0.5600	0.5600	0.8775	0.5600	0.5600	0.5600	1.0000	35
36	0.8704	0.5749	0.5749	0.5749	0.5749	0.8704	0.5749	0.5749	0.5749	1.0000	36
37	0.8631	0.5900	0.5900	0.5900	0.5900	0.8631	0.5900	0.5900	0.5900	1.0000	37
38	0.8556	0.6049	0.6049	0.6049	0.6049	0.8556	0.6049	0.6049	0.6049	1.0000	38
39	0.8479	0.6200	0.6200	0.6200	0.6200	0.8479	0.6200	0.6200	0.6200	1.0000	39
40	0.8400	0.6349	0.6349	0.6349	0.6349	0.8400	0.6349	0.6349	0.6349	1.0000	40
41	0.8319	0.6500	0.6500	0.6500	0.6500	0.8319	0.6500	0.6500	0.6500	1.0000	41
42	0.8236	0.6649	0.6649	0.6649	0.6649	0.8236	0.6649	0.6649	0.6649	1.0000	42
43	0.8151	0.6800	0.6800	0.6800	0.6800	0.8151	0.6800	0.6800	0.6800	1.0000	43
44	0.8064	0.6949	0.6949	0.6949	0.6949	0.8064	0.6949	0.6949	0.6949	1.0000	44
45	0.7975	0.7100	0.7100	0.7100	0.7100	0.7975	0.7100	0.7100	0.7100	1.0000	45
46	0.7884	0.7249	0.7249	0.7249	0.7249	0.7884	0.7249	0.7249	0.7249	1.0000	46
47	0.7791	0.7400	0.7400	0.7400	0.7400	0.7791	0.7400	0.7400	0.7400	1.0000	47
48	0.7696	0.7549	0.7549	0.7549	0.7549	0.7696	0.7549	0.7549	0.7549	1.0000	48
49	0.7600	0.7700	0.7700	0.7700	0.7700	0.7600	0.7700	0.7700	0.7700	1.0000	49
50	0.7503	0.7849	0.7849	0.7849	0.7849	0.7503	0.7849	0.7849	0.7849	1.0000	50
51	0.7404	0.8000	0.8000	0.8000	0.8000	0.7404	0.8000	0.8000	0.8000	1.0000	51
52	0.7304	0.8149	0.8149	0.8149	0.8149	0.7304	0.8149	0.8149	0.8149	1.0000	52
53	0.7202	0.8300	0.8300	0.8300	0.8300	0.7202	0.8300	0.8300	0.8300	1.0000	53
54	0.7100	0.8449	0.8449	0.8449	0.8449	0.7100	0.8449	0.8449	0.8449	1.0000	54
55	0.7000	0.8600	0.8600	0.8600	0.8600	0.7000	0.8600	0.8600	0.8600	1.0000	55
56	0.6900	0.8749	0.8749	0.8749	0.8749	0.6900	0.8749	0.8749	0.8749	1.0000	56
57	0.6800	0.8900	0.8900	0.8900	0.8900	0.6800	0.8900	0.8900	0.8900	1.0000	57
58	0.6700	0.9049	0.9049	0.9049	0.9049	0.6700	0.9049	0.9049	0.9049	1.0000	58
59	0.6600	0.9200	0.9200	0.9200	0.9200	0.6600	0.9200	0.9200	0.9200	1.0000	59
60	0.6500	0.9349	0.9349	0.9349	0.9349	0.6500	0.9349	0.9349	0.9349	1.0000	60

34°

M	Sen.	Cos.	Tan.	Col.	Sec.	Csc.	M
0	1	1.0000	0.0000	0.0000	0.0000	0.0000	0
1	0.9998	0.0174	0.0174	0.0174	0.0174	1.0000	1
2	0.9996	0.0349	0.0349	0.0349	0.0349	1.0000	2
3	0.9991	0.0523	0.0523	0.0523	0.0523	1.0000	3
4	0.9984	0.0696	0.0696	0.0696	0.0696	1.0000	4
5	0.9975	0.0868	0.0868	0.0868	0.0868	1.0000	5
6	0.9964	0.1039	0.1039	0.1039	0.1039	1.0000	6
7	0.9951	0.1209	0.1209	0.1209	0.1209	1.0000	7
8	0.9936	0.1378	0.1378	0.1378	0.1378	1.0000	8
9	0.9919	0.1546	0.1546	0.1546	0.1546	1.0000	9
10	0.9900	0.1713	0.1713	0.1713	0.1713	1.0000	10
11	0.9879	0.1879	0.1879	0.1879	0.1879	1.0000	11
12	0.9856	0.2044	0.2044	0.2044	0.2044	1.0000	12
13	0.9831	0.2208	0.2208	0.2208	0.2208	1.0000	13
14	0.9804	0.2371	0.2371	0.2371	0.2371	1.0000	14
15	0.9775	0.2533	0.2533	0.2533	0.2533	1.0000	15
16	0.9744	0.2694	0.2694	0.2694	0.2694	1.0000	16
17	0.9711	0.2854	0.2854	0.2854	0.2854	1.0000	17
18	0.9676	0.3013	0.3013	0.3013	0.3013	1.0000	18
19	0.9639	0.3171	0.3171	0.3171	0.3171	1.0000	19
20	0.9600	0.3328	0.3328	0.3328	0.3328	1.0000	20
21	0.9559	0.3484	0.3484	0.3484	0.3484	1.0000	21
22	0.9516	0.3639	0.3639	0.3639	0.3639	1.0000	22
23	0.9471	0.3793	0.3793	0.3793	0.3793	1.0000	23
24	0.9424	0.3946	0.3946	0.3946	0.3946	1.0000	24
25	0.9375	0.4098	0.4098	0.4098	0.4098	1.0000	25
26	0.9324	0.4249	0.4249	0.4249	0.4249	1.0000	26
27	0.9271	0.4400	0.4400	0.4400	0.4400	1.0000	27
28	0.9216	0.4549	0.4549	0.4549	0.4549	1.0000	28
29	0.9159	0.4700	0.4700	0.4700	0.4700	1.0000	29
30	0.9100	0.4849	0.4849	0.4849	0.4849	1.0000	30
31	0.9039	0.5000	0.5000	0.5000	0.5000	1.0000	31
32	0.8976	0.5149	0.5149	0.5149	0.5149	1.0000	32
33	0.8911	0.5300	0.5300	0.5300	0.5300	1.0000	33
34	0.8844	0.5449	0.5449	0.5449	0.5449	1.0000	34
35	0.8775	0.5600	0.5600	0.5600	0.5600	1.0000	35
36	0.8704	0.5749	0.5749	0.5749	0.5749	1.0000	36
37	0.8631	0.5900	0.5900	0.5900	0.5900	1.0000	37
38	0.8556	0.6049	0.6049	0.6049	0.6049	1.0000	38
39	0.8479	0.6200	0.6200	0.6200	0.6200	1.0000	39
40	0.8400	0.6349	0.6349	0.6349	0.6349	1.0000	40
41	0.8319	0.6500	0.6500	0.6500	0.6500	1.0000	41
42	0.8236	0.6649	0.6649	0.6649	0.6649	1.0000	42
43	0.8151	0.6800	0.6800	0.6800	0.6800	1.0000	43
44	0.8064	0.6949	0.6949	0.6949	0.6949	1.0000	44
45	0.7975	0.7100	0.7100	0.7100	0.7100	1.0000	45
46	0.7884	0.7249	0.7249	0.7249	0.7249	1.0000	46
47	0.7791	0.7400	0.7400	0.7400	0.7400	1.0000	47
48	0.7696	0.7549	0.7549	0.7549	0.7549	1.0000	48
49	0.7600	0.7700	0.7700	0.7700	0.7700	1.0000	49

M	Sen.	Cos.	Tan.	Col.	Sec.	Csc.	M
0	58178	80302	76554	1.3764	1.2361	1.7013	60
1	58202	80285	76589	3.755	2.363	7.006	59
2	58225	80267	76624	3.747	2.366	6.999	58
3	58249	80250	76658	3.739	2.368	6.993	57
4	58273	80233	76692	3.730	2.371	6.986	56
5	58296	80216	76726	3.721	2.374	6.979	55
6	58320	80200	76760	3.712	2.377	6.972	54
7	58343	80184	76794	3.703	2.379	6.965	53
8	58367	80167	76828	3.695	2.382	6.958	52
9	58390	80151	76862	3.688	2.384	6.952	51
10	58414	80135	76896	3.680	2.387	6.945	50
11	58437	80119	76930	3.672	2.389	6.938	49
12	58460	80103	76964	3.663	2.392	6.932	48
13	58484	80087	77000	3.655	2.395	6.925	47
14	58507	80071	77036	3.647	2.397	6.918	46
15	58531	80055	77072	3.639	2.400	6.911	45
16	58554	80039	77108	3.631	2.402	6.904	44
17	58578	80023	77144	3.623	2.405	6.897	43
18	58601	80007	77180	3.615	2.408	6.890	42
19	58625	79991	77216	3.607	2.411	6.883	41
20	58648	79975	77252	3.600	2.413	6.876	40
21	58672	79959	77288	3.592	2.416	6.869	39
22	58695	79943	77324	3.585	2.418	6.862	38
23	58719	79927	77360	3.577	2.421	6.855	37
24	58742	79911	77396	3.570	2.423	6.848	36
25	58766	79895	77432	3.562	2.425	6.841	35
26	58789	79879	77468	3.555	2.427	6.834	34
27	58812	79863	77504	3.547	2.429	6.827	33
28	58835	79847	77540	3.540	2.431	6.820	32
29	58858	79831	77576	3.532	2.433	6.813	31
30	58881	79815	77612	3.525	2.435	6.806	30
31	58904	79799	77648	3.517	2.437	6.799	29
32	58927	79783	77684	3.510	2.440	6.792	28
33	58950	79767	77720	3.502	2.442	6.785	27
34	58973	79751	77756	3.495	2.444	6.778	26
35	58996	79735	77792	3.487	2.446	6.771	25
36	59019	79719	77828	3.480	2.448	6.764	24
37	59042	79703	77864	3.472	2.450	6.757	23
38	59065	79687	77900	3.465	2.452	6.750	22
39	59088	79671	77936	3.457	2.454	6.743	21
40	59111	79655	77972	3.450	2.456	6.736	20
41	59134	79639	78008	3.442	2.458	6.729	19
42	59157	79623	78044	3.435	2.460	6.722	18
43	59180	79607	78080	3.427	2.462	6.715	17
44	59203	79591	78116	3.420	2.464	6.708	16
45	59226	79575	78152	3.412	2.466	6.701	15
46	59249	79559	78188	3.405	2.468	6.694	14
47	59272	79543	78224	3.397	2.470	6.687	13
48	59295	79527	78260	3.390	2.472	6.680	12
49	59318	79511	78296	3.382	2.474	6.673	11
50	59341	79495	78332	3.375	2.476	6.666	10
51	59364	79479	78368	3.367	2.478	6.659	9
52	59387	79463	78404	3.360	2.480	6.652	8
53	59410	79447	78440	3.352	2.482	6.645	7
54	59433	79431	78476	3.345	2.484	6.638	6
55	59456	79415	78512	3.337	2.486	6.631	5
56	59479	79399	78548	3.330	2.488	6.624	4
57	59502	79383	78584	3.322	2.490	6.617	3
58	59525	79367	78620	3.315	2.492	6.610	2
59	59548	79351	78656	3.307	2.494	6.603	1
60	59571	79335	78692	3.300	2.496	6.596	0

M	Sen.	Cos.	Tan.	Col.	Sec.	Csc.	M
0	60181	75863	75355	1.3710	1.2521	1.6616	60
1	60205	75846	75407	3.762	2.362	6.610	59
2	60228	75828	75447	3.754	2.365	6.603	58
3	60251	75811	75488	3.746	2.368	6.596	57
4	60274	75793	75528	3.738	2.371	6.589	56
5	60298	75776	75568	3.730	2.374	6.582	55
6	60320	75758	75608	3.722	2.377	6.575	54
7	60343	75741	75648	3.714	2.380	6.568	53
8	60367	75724	75688	3.706	2.383	6.561	52
9	60390	75706	75728	3.698	2.386	6.554	51
10	60413	75689	75768	3.690	2.389	6.547	50
11	60437	75672	75808	3.682	2.392	6.540	49
12	60460	75655	75848	3.674	2.395	6.533	48
13	60483	75638	75888	3.666	2.398	6.526	47
14	60506	75621	75928	3.658	2.401	6.519	46
15	60529	75604	75968	3.650	2.404	6.512	45
16	60552	75587	76008	3.642	2.407	6.505	44
17	60575	75570	76048	3.634	2.410	6.498	43
18	60598	75553	76088	3.626	2.413	6.491	42
19	60622	75536	76128	3.618	2.416	6.484	41
20	60645	75519	76168	3.610	2.419	6.477	40
21	60668	75502	76208	3.602	2.422	6.470	39
22	60691	75485	76248	3.594	2.425	6.463	38
23	60714	75468	76288	3.586	2.428	6.456	37
24	60737	75451	76328	3.578	2.431	6.449	36
25	60761	75434	76368	3.570	2.434	6.442	35
26	60784	75417	76408	3.562	2.437	6.435	34
27	60807	75400	76448	3.554	2.440	6.428	33
28	60830	75383	76488	3.546	2.443	6.421	32
29	60853	75366	76528	3.538	2.446	6.414	31
30	60876	75349	76568	3.530	2.449	6.407	30
31	60899	75332	76608	3.522	2.452	6.400	29
32	60922	75315	76648	3.514	2.455	6.393	28
33	60945	75298	76688	3.506	2.458	6.386	27
34	60968	75281	76728	3.498	2.461	6.379	26
35	60991	75264	76768	3.490	2.464	6.372	25
36	61014	75247	76808	3.482	2.467	6.365	24
37	61037	75230	76848	3.474	2.470	6.358	23
38	61060	75213	76888	3.466	2.473	6.351	22
39	61083	75196	76928	3.458	2.476	6.344	21
40	61106	75179	76968	3.450	2.479	6.337	20
41	61129	75162	77008	3.442	2.482	6.330	19
42	61152	75145	77048	3.434	2.485	6.323	18
43	61175	75128	77088	3.426	2.488	6.316	17
44	61198	75111	77128	3.418	2.491	6.309	16
45	61221	75094	77168	3.410	2.494	6.302	15
46	61244	75077	77208	3.402	2.497	6.295	14
47	61267	75060	77248	3.394	2.500	6.288	13
48	61290	75043	77288	3.386	2.503	6.281	12
49	61313	75026	77328	3.378	2.506	6.274	11
50	61336	75009	77368	3.370	2.509	6.267	10
51	61359	74992	77408	3.362	2.512	6.260	9
52	61382	74975	77448	3.354	2.515	6.253	8
53	61405	74958	77488	3.346	2.518	6.246	7
54	61428	74941	77528	3.338	2.521	6.239	6
55	61451	74924	77568	3.330	2.524	6.232	5
56	61474	74907	77608	3.322	2.527	6.225	4
57	61497	74890	77648	3.314	2.530	6.218	3
58	61520	74873	77688	3.306	2.533	6.211	2
59	61543	74856	77728	3.298	2.536	6.204	1
60	61566	74839	77768	3.290	2.539	6.197	0

38°

M	Sen.	Cos.	Tan.	Cot.	Sec.	Csc.	M
0	.61566	.78801	.78128	1.2799	1.2690	1.6243	60
1	.61589	.78783	.78175	.2792	.2693	.6237	59
2	.61612	.78765	.78222	.2784	.2696	.6231	58
3	.61635	.78747	.78269	.2776	.2699	.6224	57
4	.61658	.78729	.78316	.2769	.2702	.6218	56
5	.61681	.78711	.78363	1.2761	1.2705	1.6212	55
6	.61703	.78693	.78410	.2753	.2707	.6206	54
7	.61726	.78675	.78457	.2746	.2710	.6200	53
8	.61749	.78657	.78504	.2738	.2713	.6194	52
9	.61772	.78640	.78551	.2730	.2716	.6188	51
10	.61795	.78622	.78598	1.2723	1.2719	1.6182	50
11	.61818	.78604	.78645	.2715	.2722	.6176	49
12	.61841	.78586	.78692	.2708	.2725	.6170	48
13	.61864	.78568	.78739	.2700	.2728	.6164	47
14	.61886	.78550	.78786	.2692	.2731	.6159	46
15	.61909	.78532	.78833	1.2685	1.2734	1.6153	45
16	.61932	.78514	.78881	.2677	.2737	.6147	44
17	.61955	.78496	.78928	.2670	.2739	.6141	43
18	.61978	.78478	.78975	.2662	.2742	.6135	42
19	.62001	.78460	.79022	.2655	.2745	.6129	41
20	.62023	.78441	.79070	1.2647	1.2748	1.6123	40
21	.62046	.78423	.79117	.2639	.2751	.6117	39
22	.62069	.78405	.79164	.2632	.2754	.6111	38
23	.62092	.78387	.79212	.2624	.2757	.6105	37
24	.62115	.78369	.79259	.2617	.2760	.6099	36
25	.62137	.78351	.79306	1.2609	1.2763	1.6093	35
26	.62160	.78333	.79354	.2602	.2766	.6087	34
27	.62183	.78315	.79401	.2594	.2769	.6081	33
28	.62206	.78297	.79449	.2587	.2772	.6077	32
29	.62229	.78279	.79496	.2579	.2775	.6070	31
30	.62251	.78261	.79543	1.2572	1.2778	1.6064	30
31	.62274	.78243	.79591	.2564	.2781	.6058	29
32	.62297	.78224	.79639	.2557	.2784	.6052	28
33	.62320	.78206	.79686	.2549	.2787	.6046	27
34	.62342	.78188	.79734	.2542	.2790	.6040	26
35	.62365	.78170	.79781	1.2534	1.2793	1.6034	25
36	.62388	.78152	.79829	.2527	.2795	.6029	24
37	.62411	.78134	.79876	.2519	.2798	.6023	23
38	.62433	.78116	.79924	.2512	.2801	.6017	22
39	.62456	.78097	.79972	.2504	.2804	.6011	21
40	.62479	.78079	.80020	1.2497	1.2807	1.6005	20
41	.62501	.78061	.80067	.2489	.2810	.6000	19
42	.62524	.78043	.80115	.2482	.2813	.5994	18
43	.62547	.78025	.80163	.2475	.2816	.5988	17
44	.62570	.78007	.80211	.2467	.2819	.5982	16
45	.62592	.77988	.80258	1.2460	1.2822	1.5976	15
46	.62615	.77970	.80306	.2452	.2825	.5971	14
47	.62638	.77952	.80354	.2445	.2828	.5965	13
48	.62660	.77934	.80402	.2437	.2831	.5959	12
49	.62683	.77915	.80450	.2430	.2834	.5953	11
50	.62706	.77897	.80498	1.2423	1.2837	1.5947	10
51	.62728	.77879	.80546	.2415	.2840	.5942	9
52	.62751	.77861	.80594	.2408	.2843	.5936	8
53	.62774	.77842	.80642	.2400	.2846	.5930	7
54	.62796	.77824	.80690	.2393	.2849	.5924	6
55	.62819	.77806	.80738	1.2386	1.2852	1.5919	5
56	.62841	.77788	.80786	.2378	.2855	.5913	4
57	.62864	.77769	.80834	.2371	.2858	.5907	3
58	.62887	.77751	.80882	.2364	.2861	.5901	2
59	.62909	.77733	.80930	.2356	.2864	.5896	1
60	.62932	.77715	.80978	1.2349	1.2867	1.5890	0

51°

168

M	Sen.	Cos.	Tan.	Cot.	Sec.	Csc.	M
0	.62932	.77715	.80978	1.2349	1.2867	1.5890	60
1	.62955	.77696	.81026	2.342	2871	5884	59
2	.62977	.77678	.81075	2.334	2874	5879	58
3	.63000	.77660	.81123	2.327	2877	5873	57
4	.63022	.77641	.81171	2.320	2880	5867	56
5	.63045	.77623	.81219	1.2312	1.2883	1.5862	55
6	.63067	.77605	.81268	.2305	2886	5856	54
7	.63090	.77586	.81316	.2297	2889	5850	53
8	.63113	.77568	.81364	.2290	2892	5845	52
9	.63135	.77549	.81413	.2283	2895	5839	51
10	.63158	.77531	.81461	1.2276	1.2898	1.5833	50
11	.63180	.77513	.81509	.2268	2901	5828	49
12	.63203	.77494	.81558	.2261	2904	5822	48
13	.63225	.77476	.81506	.2254	2907	5816	47
14	.63248	.77458	.81555	.2247	2910	5811	46
15	.63270	.77439	.81703	1.2239	1.2913	1.5805	45
16	.63293	.77421	.81752	.2232	2916	5799	44
17	.63315	.77402	.81800	.2225	2919	5794	43
18	.63338	.77384	.81849	.2218	2922	5788	42
19	.63360	.77365	.81898	.2210	2925	5783	41
20	.63383	.77347	.81946	1.2203	1.2929	1.5777	40
21	.63405	.77329	.81995	.2195	2932	5771	39
22	.63428	.77310	.82043	.2189	2935	5766	38
23	.63450	.77292	.82092	.2181	2938	5760	37
24	.63473	.77273	.82141	.2174	2941	5755	36
25	.63495	.77255	.82190	1.2167	1.2944	1.5749	35
26	.63518	.77236	.82238	.2160	2947	5743	34
27	.63540	.77218	.82287	.2152	2950	5738	33
28	.63563	.77199	.82336	.2145	2953	5732	32
29	.63585	.77181	.82385	.2138	2956	5727	31
30	.63608	.77162	.82434	1.2131	1.2960	1.5721	30
31	.63630	.77144	.82482	.2124	2963	5716	29
32	.63653	.77125	.82531	.2117	2966	5710	28
33	.63675	.77107	.82580	.2109	2969	5705	27
34	.63697	.77088	.82629	.2102	2972	5699	26
35	.63720	.77070	.82678	1.2095	1.2975	1.5694	25
36	.63742	.77051	.82727	.2088	2978	5688	24
37	.63765	.77033	.82776	.2081	2981	5683	23
38	.63787	.77014	.82825	.2074	2985	5677	22
39	.63810	.76996	.82874	.2066	2988	5672	21
40	.63832	.76977	.82923	1.2059	1.2991	1.5666	20
41	.63854	.76958	.82972	.2052	2994	5661	19
42	.63877	.76940	.83022	.2045	2997	5655	18
43	.63899	.76921	.83071	.2038	3000	5650	17
44	.63921	.76903	.83120	.2031	3003	5644	16
45	.63944	.76884	.83169	1.2024	1.3006	1.5639	15
46	.63966	.76865	.83218	.2016	3010	5633	14
47	.63989	.76847	.83267	.2009	3013	5628	13
48	.64011	.76828	.83317	.2002	3016	5622	12
49	.64033	.76810	.83366	.1995	3019	5617	11
50	.64056	.76791	.83415	1.1988	1.3022	1.5611	10
51	.64078	.76772	.83465	.1981	3025	5606	9
52	.64100	.76754	.83514	.1974	3029	5600	8
53	.64123	.76735	.83563	.1967	3032	5595	7
54	.64145	.76716	.83613	.1960	3035	5590	6
55	.64167	.76698	.83662	1.1953	1.3038	1.5584	5
56	.64189	.76679	.83712	.1946	3041	5579	4
57	.64212	.76660	.83761	.1939	3044	5573	3
58	.64234	.76642	.83811	.1932	3048	5568	2
59	.64256	.76623	.83860	.1924	3051	5563	1
60	.64279	.76604	.83910	1.1917	1.3054	1.5557	0

M	Sen.	Cos.	Tan.	Col.	Sec.	Csc.	M
0	64279	75584	83910	1.1917	1.3054	1.5551	60
1	64301	75585	83959	1.910	3.057	5.572	59
2	64323	75587	84005	1.903	3.060	5.586	58
3	64345	75588	84050	1.896	3.064	5.601	57
4	64368	75589	84108	1.889	3.067	5.616	56
5	64390	75591	84165	1.882	3.070	5.631	55
6	64412	75592	84228	1.875	3.073	5.645	54
7	64435	75593	84291	1.868	3.076	5.659	53
8	64457	75594	84357	1.861	3.080	5.674	52
9	64479	75595	84427	1.854	3.083	5.689	51
10	64501	75596	84499	1.847	3.087	5.704	50
11	64523	75597	84575	1.840	3.090	5.719	49
12	64546	75598	84656	1.833	3.093	5.734	48
13	64568	75599	84741	1.826	3.096	5.749	47
14	64590	75600	84830	1.819	3.099	5.764	46
15	64612	75601	84923	1.812	3.102	5.779	45
16	64635	75602	85020	1.805	3.105	5.794	44
17	64657	75603	85121	1.798	3.109	5.809	43
18	64679	75604	85226	1.791	3.112	5.824	42
19	64701	75605	85335	1.785	3.115	5.839	41
20	64723	75606	85447	1.778	3.118	5.854	40
21	64745	75607	85562	1.771	3.121	5.869	39
22	64768	75608	85680	1.764	3.125	5.884	38
23	64790	75609	85800	1.757	3.128	5.899	37
24	64812	75610	85923	1.750	3.131	5.914	36
25	64834	75611	86049	1.743	3.134	5.929	35
26	64856	75612	86178	1.736	3.138	5.944	34
27	64878	75613	86309	1.729	3.141	5.959	33
28	64900	75614	86442	1.722	3.144	5.974	32
29	64923	75615	86577	1.715	3.148	5.989	31
30	64945	75616	86714	1.708	3.151	6.004	30
31	64968	75617	86853	1.702	3.154	6.019	29
32	64990	75618	86994	1.695	3.157	6.034	28
33	65012	75619	87137	1.688	3.161	6.049	27
34	65034	75620	87282	1.681	3.164	6.064	26
35	65055	75621	87429	1.674	3.167	6.079	25
36	65077	75622	87578	1.667	3.170	6.094	24
37	65100	75623	87729	1.660	3.174	6.109	23
38	65121	75624	87881	1.653	3.177	6.124	22
39	65144	75625	88035	1.647	3.180	6.139	21
40	65166	75626	88190	1.640	3.184	6.154	20
41	65188	75627	88347	1.633	3.187	6.169	19
42	65210	75628	88505	1.626	3.190	6.184	18
43	65232	75629	88664	1.619	3.193	6.199	17
44	65254	75630	88825	1.612	3.196	6.214	16
45	65276	75631	88987	1.605	3.200	6.229	15
46	65298	75632	89151	1.598	3.203	6.244	14
47	65320	75633	89317	1.591	3.207	6.259	13
48	65342	75634	89484	1.584	3.210	6.274	12
49	65364	75635	89653	1.577	3.213	6.289	11
50	65386	75636	89823	1.570	3.217	6.304	10
51	65408	75637	89994	1.563	3.220	6.319	9
52	65430	75638	90167	1.556	3.223	6.334	8
53	65452	75639	90341	1.549	3.227	6.349	7
54	65474	75640	90517	1.542	3.230	6.364	6
55	65496	75641	90694	1.535	3.233	6.379	5
56	65518	75642	90872	1.528	3.237	6.394	4
57	65540	75643	91052	1.521	3.240	6.409	3
58	65562	75644	91233	1.514	3.243	6.424	2
59	65584	75645	91415	1.507	3.247	6.439	1
60	65605	75646	91598	1.500	3.250	6.454	0

M	Sen.	Cos.	Tan.	Col.	Sec.	Csc.	M
0	65616	75671	86329	1.1504	1.3250	1.5242	60
1	65628	75452	86380	1.4937	3.253	5.573	59
2	65650	75433	87031	1.490	3.257	5.588	58
3	65672	75414	87682	1.483	3.260	5.603	57
4	65694	75394	88333	1.477	3.263	5.617	56
5	65716	75375	88984	1.470	3.267	5.632	55
6	65738	75355	89635	1.463	3.270	5.647	54
7	65760	75337	90286	1.456	3.274	5.661	53
8	65782	75318	90937	1.450	3.277	5.676	52
9	65804	75299	91588	1.443	3.280	5.691	51
10	65825	75280	92239	1.436	3.284	5.705	50
11	65847	75261	92890	1.430	3.287	5.720	49
12	65869	75242	93541	1.423	3.290	5.734	48
13	65891	75222	94192	1.416	3.294	5.749	47
14	65913	75203	94843	1.409	3.297	5.764	46
15	65934	75184	95494	1.403	3.301	5.779	45
16	65956	75165	96145	1.396	3.304	5.794	44
17	65978	75146	96796	1.389	3.308	5.809	43
18	66000	75127	97447	1.383	3.311	5.824	42
19	66022	75107	98098	1.376	3.314	5.839	41
20	66044	75088	98749	1.369	3.318	5.854	40
21	66066	75069	99400	1.363	3.321	5.869	39
22	66087	75050	100051	1.356	3.324	5.884	38
23	66109	75031	100702	1.349	3.328	5.899	37
24	66131	75011	101353	1.343	3.331	5.914	36
25	66153	74992	102004	1.336	3.335	5.929	35
26	66175	74973	102655	1.329	3.338	5.944	34
27	66197	74953	103306	1.322	3.342	5.959	33
28	66218	74934	103957	1.316	3.345	5.974	32
29	66240	74914	104608	1.309	3.348	5.989	31
30	66262	74895	105259	1.303	3.351	6.004	30
31	66284	74875	105910	1.296	3.355	6.019	29
32	66305	74857	106561	1.290	3.358	6.034	28
33	66327	74838	107212	1.283	3.362	6.049	27
34	66349	74818	107863	1.276	3.365	6.064	26
35	66371	74799	108514	1.270	3.369	6.079	25
36	66393	74780	109165	1.263	3.372	6.094	24
37	66414	74760	109816	1.257	3.375	6.109	23
38	66436	74741	110467	1.250	3.379	6.124	22
39	66458	74722	111118	1.243	3.382	6.139	21
40	66480	74702	111769	1.236	3.385	6.154	20
41	66502	74683	112420	1.230	3.389	6.169	19
42	66523	74664	113071	1.223	3.392	6.184	18
43	66545	74645	113722	1.217	3.395	6.199	17
44	66566	74625	114373	1.210	3.399	6.214	16
45	66588	74606	115024	1.204	3.402	6.229	15
46	66610	74586	115675	1.197	3.405	6.244	14
47	66632	74567	116326	1.190	3.409	6.259	13
48	66653	74548	116977	1.184	3.412	6.274	12
49	66675	74528	117628	1.177	3.415	6.289	11
50	66697	74509	118279	1.170	3.418	6.304	10
51	66719	74490	118930	1.163	3.422	6.319	9
52	66741	74470	119581	1.156	3.425	6.334	8
53	66762	74451	120232	1.150	3.428	6.349	7
54	66784	74431	120883	1.143	3.431	6.364	6
55	66805	74412	121534	1.136	3.435	6.379	5
56	66826	74392	122185	1.130	3.438	6.394	4
57	66848	74373	122836	1.123	3.441	6.409	3
58	66869	74353	123487	1.116	3.445	6.424	2
59	66891	74334	124138	1.110	3.448	6.439	1
60	66913	74314	124789	1.103	3.451	6.454	0

M	Sen.	Cos.	Tan.	Col.	Sec.	Csc.	M
0	66913	.74314	.90040	1.1106	1.3456	1.4945	60
1	66935	.74295	.90093	.1100	.3460	.4940	59
2	66956	.74275	.90146	.1093	.3463	.4935	58
3	66978	.74256	.90198	.1086	.3467	.4930	57
4	66999	.74236	.90251	.1080	.3470	.4925	56
5	67021	.74217	.90304	1.1074	1.3474	1.4921	55
6	67043	.74197	.90357	.1067	.3477	.4916	54
7	67064	.74178	.90410	.1061	.3481	.4911	53
8	67086	.74158	.90463	.1054	.3485	.4906	52
9	67107	.74139	.90515	.1048	.3488	.4901	51
10	67129	.74119	.90568	1.1041	1.3492	1.4897	50
11	67150	.74100	.90621	.1035	.3495	.4892	49
12	67172	.74080	.90674	.1028	.3499	.4887	48
13	67194	.74061	.90727	.1022	.3502	.4882	47
14	67215	.74041	.90780	.1015	.3506	.4877	46
15	67237	.74022	.90834	1.1009	1.3509	1.4873	45
16	67258	.74002	.90887	.1003	.3513	.4868	44
17	67280	.73983	.90940	.0996	.3517	.4863	43
18	67301	.73963	.90993	.0990	.3520	.4858	42
19	67323	.73943	.91046	.0983	.3524	.4854	41
20	67344	.73924	.91099	1.0977	1.3527	1.4849	40
21	67366	.73904	.91153	.0971	.3531	.4844	39
22	67387	.73885	.91206	.0964	.3534	.4839	38
23	67409	.73865	.91259	.0958	.3538	.4835	37
24	67430	.73845	.91312	.0951	.3542	.4830	36
25	67452	.73826	.91366	1.0945	1.3545	1.4825	35
26	67473	.73806	.91419	.0939	.3549	.4821	34
27	67495	.73787	.91473	.0932	.3552	.4816	33
28	67516	.73767	.91526	.0926	.3556	.4811	32
29	67537	.73747	.91580	.0919	.3560	.4806	31
30	67559	.73728	.91633	1.0913	1.3563	1.4802	30
31	67580	.73708	.91687	.0907	.3567	.4797	29
32	67602	.73688	.91740	.0900	.3571	.4792	28
33	67623	.73669	.91794	.0894	.3574	.4788	27
34	67645	.73649	.91847	.0888	.3578	.4783	26
35	67666	.73629	.91901	1.0881	1.3581	1.4778	25
36	67688	.73610	.91955	.0875	.3585	.4774	24
37	67709	.73590	.92008	.0868	.3589	.4769	23
38	67730	.73570	.92062	.0862	.3592	.4764	22
39	67752	.73551	.92116	.0856	.3596	.4760	21
40	67773	.73531	.92170	1.0849	1.3600	1.4755	20
41	67794	.73511	.92223	.0843	.3603	.4750	19
42	67816	.73491	.92277	.0837	.3607	.4746	18
43	67837	.73472	.92331	.0830	.3611	.4741	17
44	67859	.73452	.92385	.0824	.3614	.4736	16
45	67880	.73432	.92439	1.0818	1.3618	1.4732	15
46	67901	.73412	.92493	.0812	.3622	.4727	14
47	67923	.73393	.92547	.0805	.3625	.4723	13
48	67944	.73373	.92601	.0799	.3629	.4718	12
49	67965	.73353	.92655	.0793	.3633	.4713	11
50	67987	.73333	.92709	1.0786	1.3636	1.4709	10
51	68008	.73314	.92763	.0780	.3640	.4704	9
52	68029	.73294	.92817	.0774	.3644	.4699	8
53	68051	.73274	.92871	.0767	.3647	.4695	7
54	68072	.73254	.92926	.0761	.3651	.4690	6
55	68093	.73234	.92980	1.0755	1.3655	1.4686	5
56	68115	.73215	.93034	.0749	.3658	.4681	4
57	68136	.73195	.93088	.0742	.3662	.4676	3
58	68157	.73175	.93143	.0736	.3666	.4672	2
59	68178	.73155	.93197	.0730	.3669	.4667	1
60	68200	.73135	.93251	1.0724	1.3673	1.4663	0

M	Sen.	Cos.	Tan.	Cot.	Sec.	Csc.	M
0	.68200	.73135	.93251	1.0724	1.3673	1.4663	60
1	.68221	.73115	.93306	.0717	.3677	.4658	59
2	.68242	.73096	.93360	.0711	.3681	.4654	58
3	.68264	.73076	.93415	.0705	.3684	.4649	57
4	.68285	.73056	.93469	.0699	.3688	.4644	56
5	.68306	.73036	.93524	1.0692	1.3692	1.4640	55
6	.68327	.73016	.93578	.0686	.3695	.4635	54
7	.68349	.72996	.93633	.0680	.3699	.4631	53
8	.68370	.72976	.93687	.0674	.3703	.4626	52
9	.68391	.72956	.93742	.0667	.3707	.4622	51
10	.68412	.72937	.93797	1.0661	1.3710	1.4617	50
11	.68433	.72917	.93851	.0655	.3714	.4613	49
12	.68455	.72897	.93906	.0649	.3718	.4608	48
13	.68476	.72877	.93961	.0643	.3722	.4604	47
14	.68497	.72857	.94016	.0636	.3725	.4599	46
15	.68518	.72837	.94071	1.0630	1.3729	1.4595	45
16	.68539	.72817	.94125	.0624	.3733	.4590	44
17	.68561	.72797	.94180	.0618	.3737	.4586	43
18	.68582	.72777	.94235	.0612	.3740	.4581	42
19	.68603	.72757	.94290	.0605	.3744	.4577	41
20	.68624	.72737	.94345	1.0599	1.3748	1.4572	40
21	.68645	.72717	.94400	.0593	.3752	.4568	39
22	.68666	.72697	.94455	.0587	.3756	.4563	38
23	.68688	.72677	.94510	.0581	.3759	.4559	37
24	.68709	.72657	.94565	.0575	.3763	.4554	36
25	.68730	.72637	.94620	1.0568	1.3767	1.4550	35
26	.68751	.72617	.94675	.0562	.3771	.4545	34
27	.68772	.72597	.94731	.0556	.3774	.4541	33
28	.68793	.72577	.94786	.0550	.3778	.4536	32
29	.68814	.72557	.94841	.0544	.3782	.4532	31
30	.68835	.72537	.94896	1.0538	1.3786	1.4527	30
31	.68856	.72517	.94952	.0532	.3790	.4523	29
32	.68878	.72497	.95007	.0525	.3794	.4518	28
33	.68899	.72477	.95062	.0519	.3797	.4514	27
34	.68920	.72457	.95118	.0513	.3801	.4510	26
35	.68941	.72437	.95173	1.0507	1.3805	1.4505	25
36	.68962	.72417	.95229	.0501	.3809	.4501	24
37	.68983	.72397	.95284	.0495	.3813	.4496	23
38	.69004	.72377	.95340	.0489	.3816	.4492	22
39	.69025	.72357	.95395	.0483	.3820	.4487	21
40	.69046	.72337	.95451	1.0476	1.3824	1.4483	20
41	.69067	.72317	.95506	.0470	.3828	.4479	19
42	.69088	.72297	.95562	.0464	.3832	.4474	18
43	.69109	.72277	.95618	.0458	.3836	.4470	17
44	.69130	.72256	.95673	.0452	.3839	.4465	16
45	.69151	.72236	.95729	1.0446	1.3843	1.4461	15
46	.69172	.72216	.95785	.0440	.3847	.4457	14
47	.69193	.72196	.95841	.0434	.3851	.4452	13
48	.69214	.72176	.95896	.0428	.3855	.4448	12
49	.69235	.72156	.95952	.0422	.3859	.4443	11
50	.69256	.72136	.96008	1.0416	1.3863	1.4439	10
51	.69277	.72115	.96064	.0410	.3867	.4435	9
52	.69298	.72095	.96120	.0404	.3870	.4430	8
53	.69319	.72075	.96176	.0397	.3874	.4426	7
54	.69340	.72055	.96232	.0391	.3878	.4422	6
55	.69361	.72035	.96288	1.0385	1.3882	1.4417	5
56	.69382	.72015	.96344	.0379	.3886	.4413	4
57	.69403	.71994	.96400	.0373	.3890	.4408	3
58	.69424	.71974	.96456	.0367	.3894	.4404	2
59	.69445	.71954	.96513	.0361	.3898	.4400	1
60	.69466	.71934	.96569	1.0355	1.3902	1.4395	0

44°

M	Sen.	Cos.	Tan.	Cot.	Sec.	Csc.	M
0	69466	71934	96569	1.0355	1.3902	1.4395	60
1	69487	71914	96625	.0349	.3905	.4391	59
2	69508	71893	96681	.0343	.3909	.4387	58
3	69528	71873	96738	.0337	.3913	.4382	57
4	69549	71853	96794	.0331	.3917	.4378	56
5	69570	71833	96850	1.0325	1.3921	1.4374	55
6	69591	71813	96907	.0319	.3925	.4370	54
7	69612	71792	96963	.0313	.3929	.4365	53
8	69633	71772	97020	.0307	.3933	.4361	52
9	69654	71752	97076	.0301	.3937	.4357	51
10	69675	71732	97133	1.0295	1.3941	1.4352	50
11	69696	71711	97189	.0289	.3945	.4348	49
12	69716	71691	97246	.0283	.3949	.4344	48
13	69737	71671	97302	.0277	.3953	.4339	47
14	69758	71650	97359	.0271	.3957	.4335	46
15	69779	71630	97416	1.0265	1.3960	1.4331	45
16	69800	71610	97472	.0259	.3964	.4327	44
17	69821	71589	97529	.0253	.3968	.4322	43
18	69841	71569	97586	.0247	.3972	.4318	42
19	69862	71549	97643	.0241	.3976	.4314	41
20	69883	71529	97700	1.0235	1.3980	1.4310	40
21	69904	71508	97756	.0229	.3984	.4305	39
22	69925	71488	97813	.0223	.3988	.4301	38
23	69945	71468	97870	.0218	.3992	.4297	37
24	69966	71447	97927	.0212	.3996	.4292	36
25	69987	71427	97984	1.0206	1.4000	1.4288	35
26	70008	71406	98041	.0200	.4004	.4284	34
27	70029	71386	98098	.0194	.4008	.4280	33
28	70049	71366	98155	.0188	.4012	.4276	32
29	70070	71345	98212	.0182	.4016	.4271	31
30	70091	71325	98270	1.0176	1.4020	1.4267	30
31	70112	71305	98327	.0170	.4024	.4263	29
32	70132	71284	98384	.0164	.4028	.4259	28
33	70153	71264	98441	.0158	.4032	.4255	27
34	70174	71243	98499	.0152	.4036	.4250	26
35	70194	71223	98556	1.0146	1.4040	1.4246	25
36	70215	71203	98613	.0141	.4044	.4242	24
37	70236	71182	98671	.0135	.4048	.4238	23
38	70257	71162	98728	.0129	.4052	.4233	22
39	70277	71141	98786	.0123	.4056	.4229	21
40	70298	71121	98843	1.0117	1.4060	1.4225	20
41	70319	71100	98901	.0111	.4065	.4221	19
42	70339	71080	98958	.0105	.4069	.4217	18
43	70360	71059	99016	.0099	.4073	.4212	17
44	70381	71039	99073	.0093	.4077	.4208	16
45	70401	71018	99131	1.0088	1.4081	1.4204	15
46	70422	70998	99189	.0082	.4085	.4200	14
47	70443	70977	99246	.0076	.4089	.4196	13
48	70463	70957	99304	.0070	.4093	.4192	12
49	70484	70936	99362	.0064	.4097	.4188	11
50	70505	70916	99420	1.0058	1.4101	1.4183	10
51	70525	70895	99478	.0052	.4105	.4179	9
52	70546	70875	99536	.0047	.4109	.4175	8
53	70566	70854	99593	.0041	.4113	.4171	7
54	70587	70834	99651	.0035	.4117	.4167	6
55	70608	70813	99709	1.0029	1.4122	1.4163	5
56	70628	70793	99767	.0023	.4126	.4159	4
57	70649	70772	99826	.0017	.4130	.4154	3
58	70669	70752	99884	.0012	.4134	.4150	2
59	70690	70731	99942	.0006	.4138	.4146	1
60	70711	70711	1.0000	1.0000	1.4142	1.4142	0

45°
174

PESO DE LA TUBERIA Y DEL AGUA POR PIE LINEAL

Tamaño nominal del tubo	PESO ESTANDAR DE:		PESO XF DE:	
	TUBO	AGUA	TUBO	AGUA
1/2	.851	.132	1.088	.101
3/4	1.131	.231	1.474	.187
1	1.679	.374	2.172	.311
1 1/4	2.273	.648	2.997	.555
1 1/2	2.718	.882	3.632	.765
2	3.653	1.453	5.022	1.278
2 1/2	5.794	2.073	7.662	1.835
3	7.58	3.20	10.25	2.86
3 1/2	9.11	4.28	12.51	3.85
4	10.79	5.51	14.99	4.98
5	14.62	8.66	20.78	7.88
6	18.98	12.51	28.58	11.29
8	28.56	21.68	43.4	19.8
10	40.5	34.1	54.7	32.3
12	49.6	49.0	65.4	47.0
14	54.6	59.7	72.1	57.5
16	62.6	79.1	82.8	76.5
18	70.6	101.2	93.5	98.3
20	78.6	126.0	104.1	122.8
24	94.6	183.8	125.5	179.9
30	118.7	291.0	157.6	286.0

CONVERSION DE CARGA DE PIES DE AGUA A LIBRAS POR PULGADA CUADRADA

CARGA EN PIES	LIBRAS POR PULGADA CUADRADA	CARGA EN PIES	LIBRAS POR PULGADA CUADRADA
1	.43	100	43.31
2	.87	110	47.64
3	1.30	120	51.97
4	1.73	130	56.30
5	2.17	140	60.63
6	2.60	150	64.96
7	3.03	160	69.29
8	3.46	170	73.63
9	3.90	180	77.96
10	4.33	200	86.62
15	6.50	250	108.27
20	8.66	300	129.93
25	10.83	350	151.58
30	12.99	400	173.24
40	17.32	500	216.55
50	21.65	600	259.85
60	25.99	700	303.16
70	30.32	800	346.47
80	34.65	900	389.78
90	38.98	1000	433.00

NOTA: Un pie de agua a 62°F equivale a una presión de 0.433 lb/pulg². Para encontrar la presión por pulgada cuadrada para cualquier carga en pies que no aparezca en la tabla anterior, multiplique la carga en pies por 0.433.

LA EDICIÓN, COMPOSICIÓN, DISEÑO E IMPRESIÓN DE ESTA OBRA FUERON REALIZADOS
BAJO LA SUPERVISIÓN DE GRUPO NORIEGA EDITORES.
BALDERAS 95, COL. CENTRO. MÉXICO, D.F. C.P. 06040
1264885000808508DP92411

Obra afín:

MANUAL DE TUBERÍA COMERCIAL

Thomas W. Frankland

Esta obra es de gran utilidad en los trabajos de plomería, instalaciones de tuberías y fabricación de tubos y accesorios para éstos. Lo anterior se debe a que incluye una serie de tablas que eliminan la necesidad de tener que calcular valores de diversas operaciones y, por consiguiente, disminuyen los errores que pueden cometerse al hacer los cálculos.

A lo largo del libro se presentan las tablas correspondientes a diversas operaciones de tubería, así como la forma en que deben usarse. Entre las operaciones que se tratan en este manual están los desplazamientos, accesorios de quiebres angulares, dobles de tubos, tubos y accesorios, ángulos, ménsulas de fierroángulos, etc. Además, se incluyen tablas de funciones trigonométricas, fórmulas geométricas, matemáticas básicas y de referencia.

Por el formato de este libro, lo pueden utilizar en el trabajo plomeros, instaladores de tubería y especialistas en ramas afines a la plomería.

Este es un manual muy útil para aprender a diseñar y a fabricar tubería y sus accesorios. Para ello el autor ha incluido una serie de diagramas y tablas que complementan los métodos de diseño y fabricación. Por ejemplo, para trazar los agujeros de tornillos en una brida, se proporciona la fórmula para encontrar la distancia de un agujero a otro, así como una tabla con el número de agujeros y el diámetro del círculo de los mismos.

La obra comienza con los métodos de determinación de ángulos y longitudes de tubería mediante el uso de funciones trigonométricas. En el resto del libro se presentan operaciones tales como cortes angulares en tuberías, intersecciones excéntricas, ángulos entre los agujeros para tornillos en las bridas, trazado de plantillas, cortes angulares de los fierroángulos y ménsulas de los mismos, y desplazamientos especiales. También se proporcionan tablas de dimensiones de: conexiones soldables, accesorios soldables de campana y roscado, válvulas bridadas de acero fundido, accesorios bridados de acero fundido, etcétera. Para finalizar se incluye una serie de constantes de conversión, equivalentes decimales y tablas trigonométricas.

Debido a la simplificación de las explicaciones y los métodos, es un excelente manual para plomeros, instaladores de tubería y especialistas en ramas afines a la plomería.

GRUPO

NORIEGA EDITORES

limusa@noriegaeditores.com

www.noriega.com.mx

◀ Portada: Sergio Olguín

ÁREA: ING. MECÁNICA/TECNOLÓGICAS

ISBN 13: 978-968-18-1707-7



9 789681 817077

